

**1997 Ford Pickup F150**

1997 System Wiring Diagrams Ford - Pickup F150

**1997 System Wiring Diagrams**

**Ford - Pickup F150**

**AIR CONDITIONING**



**1997 Ford Pickup F150**

1997 System Wiring Diagrams Ford - Pickup F150

**Fig. 1: A/C Circuit, Vehicles Built Before 6/24/96**

# 1997 Ford Pickup F150

## 1997 System Wiring Diagrams Ford - Pickup F150

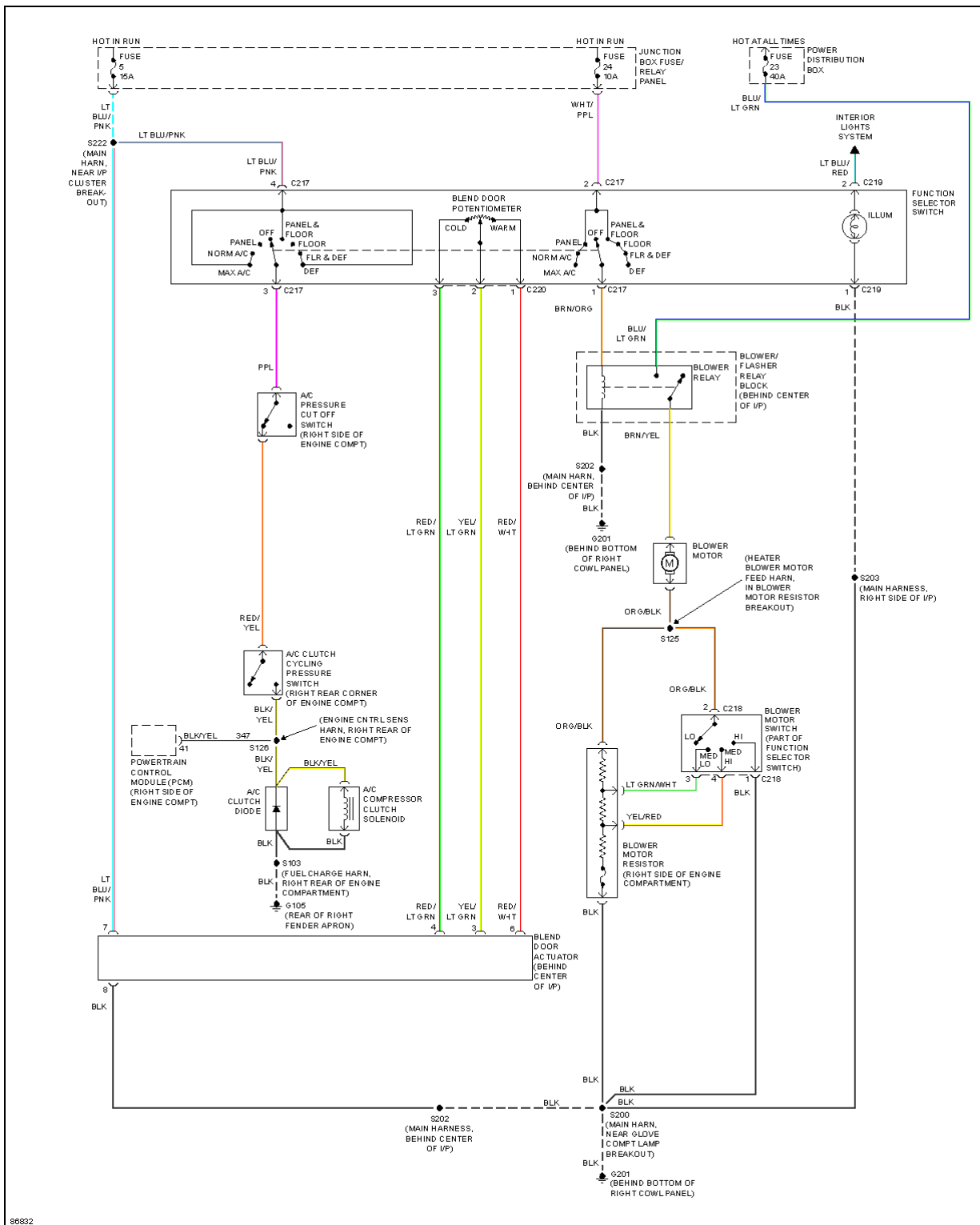

**1997 Ford Pickup F150**

1997 System Wiring Diagrams Ford - Pickup F150

**Fig. 2: A/C Circuit, Vehicles Built On or After 6/24/96**

# 1997 Ford Pickup F150

## 1997 System Wiring Diagrams Ford - Pickup F150

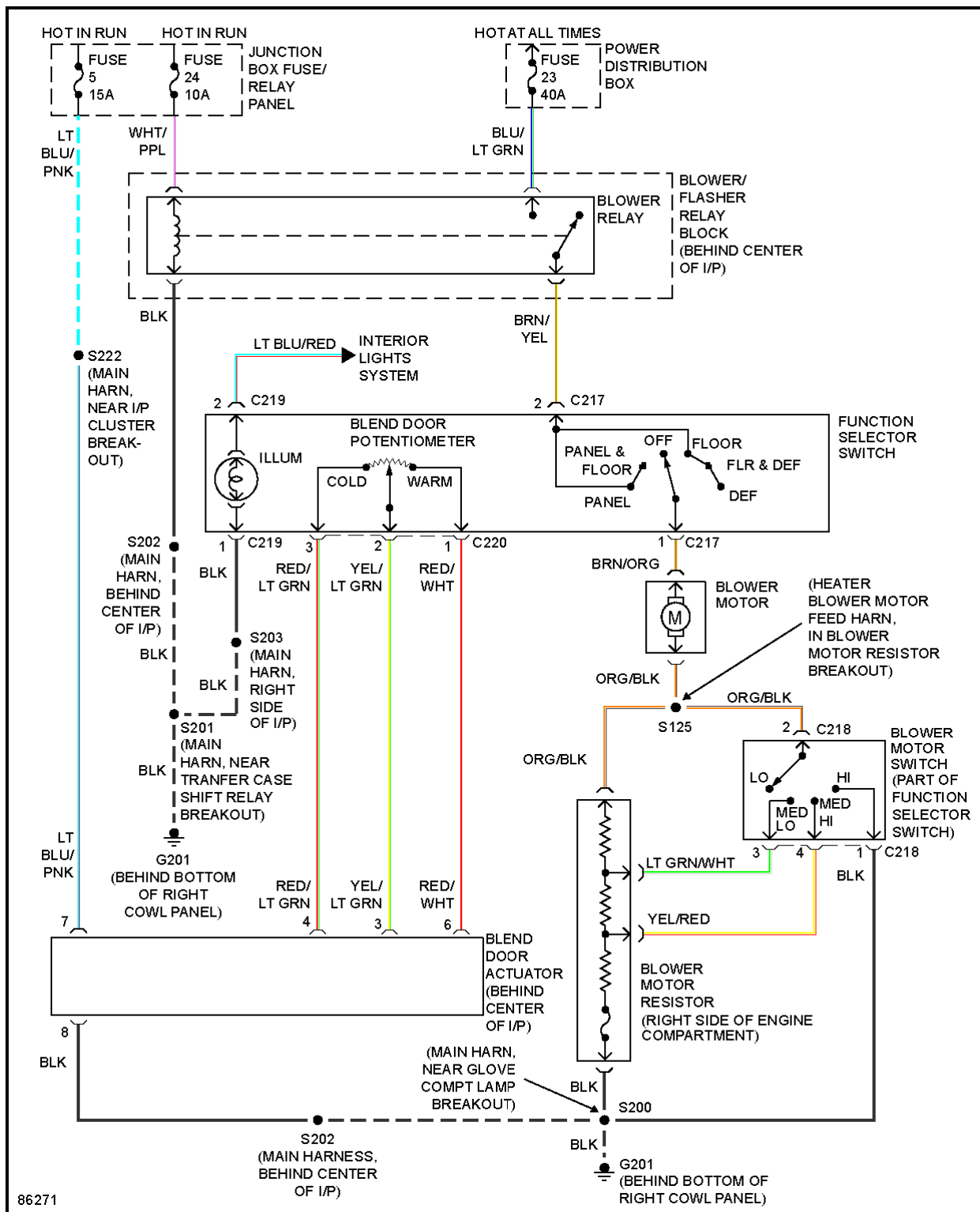

**1997 Ford Pickup F150**

1997 System Wiring Diagrams Ford - Pickup F150

**Fig. 3: Heater Circuit, Vehicles Built Before 6/24/96**

# 1997 Ford Pickup F150

## 1997 System Wiring Diagrams Ford - Pickup F150

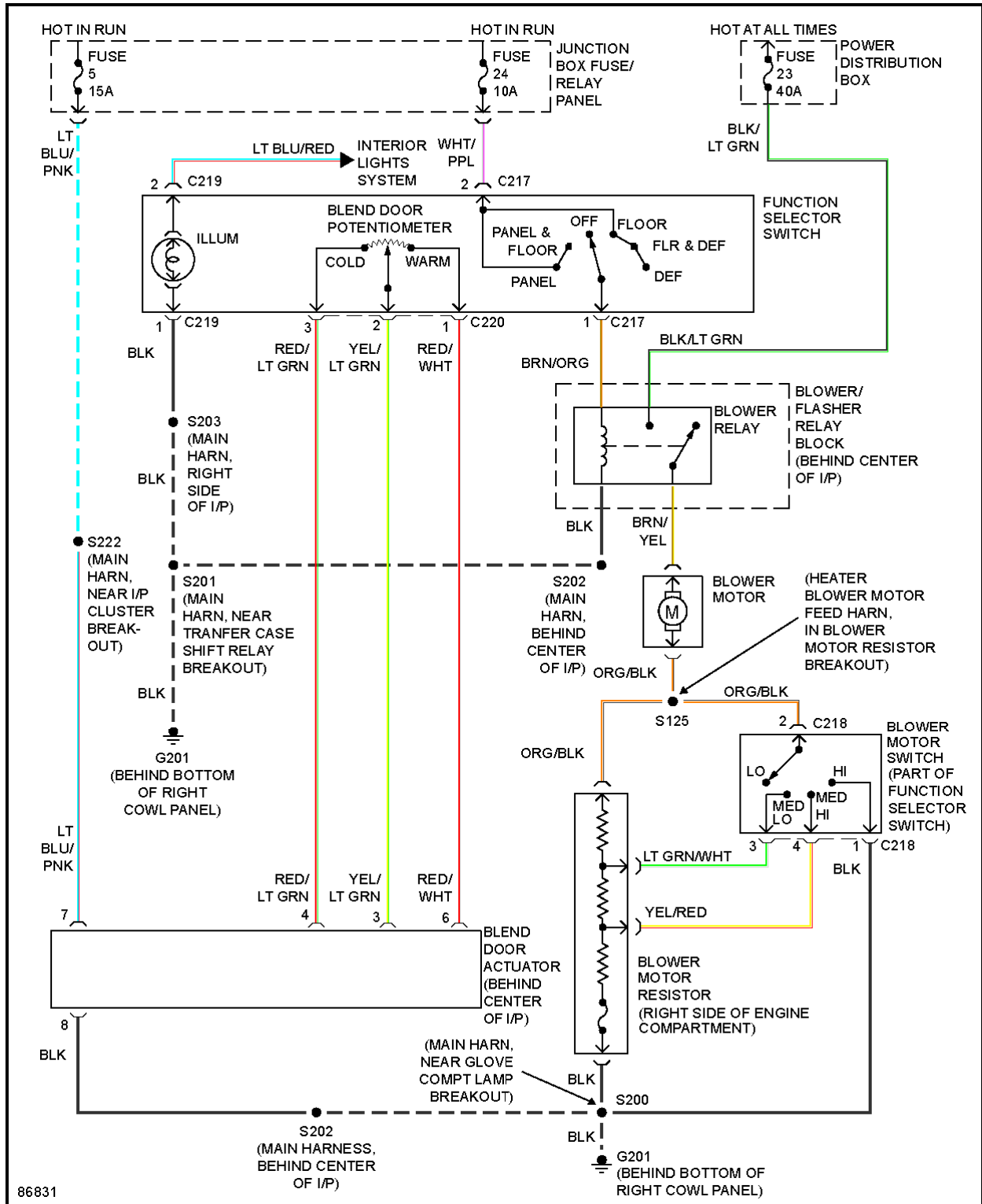



## 1997 Ford Pickup F150

1997 System Wiring Diagrams Ford - Pickup F150

**Fig. 4: Heater Circuit, Vehicles Built On or After 6/24/96**

### **ANTI-LOCK BRAKES**

# 1997 Ford Pickup F150

## 1997 System Wiring Diagrams Ford - Pickup F150

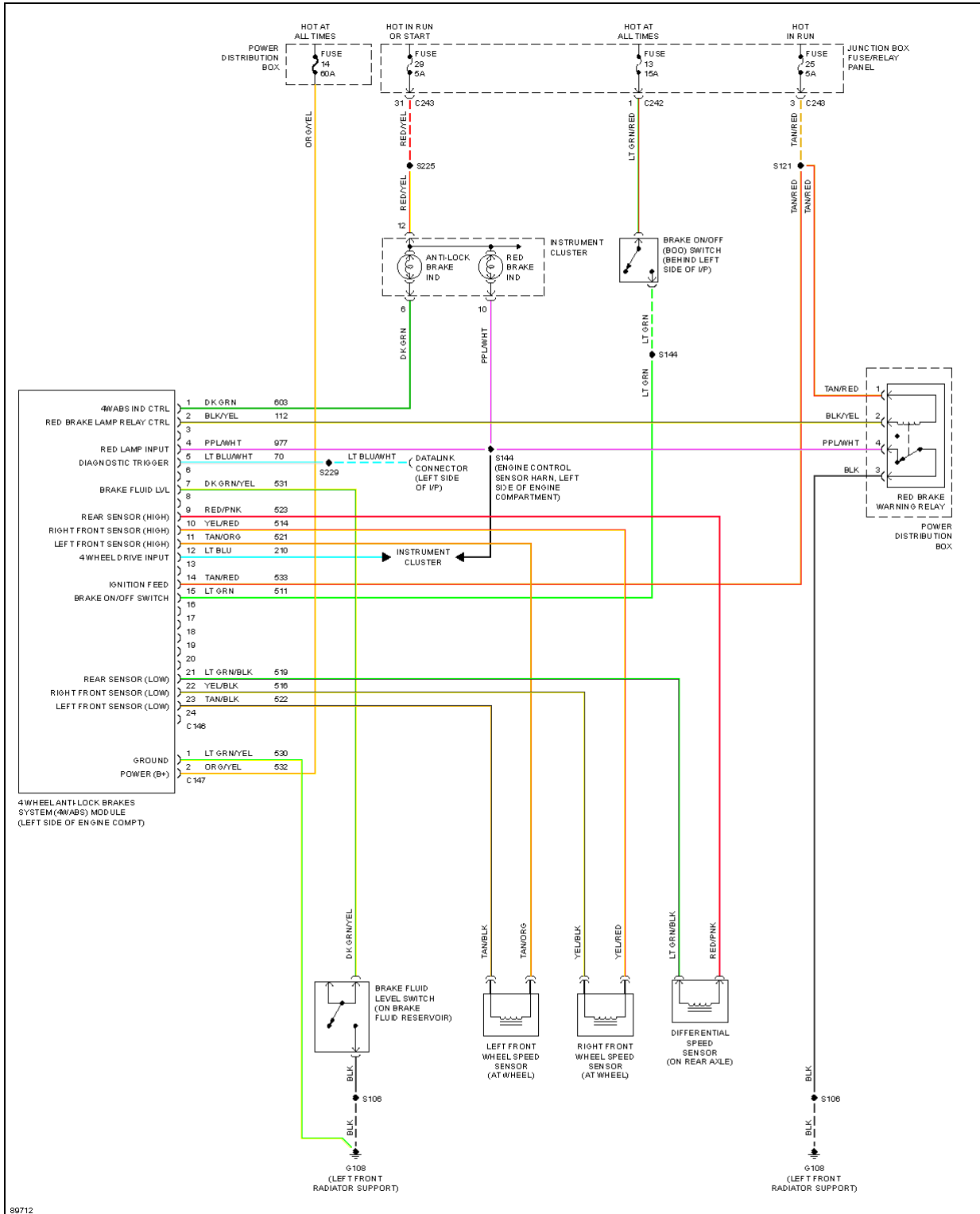

## 1997 Ford Pickup F150

1997 System Wiring Diagrams Ford - Pickup F150

### **Fig. 5: All-Wheel ABS Circuit**

# 1997 Ford Pickup F150

## 1997 System Wiring Diagrams Ford - Pickup F150

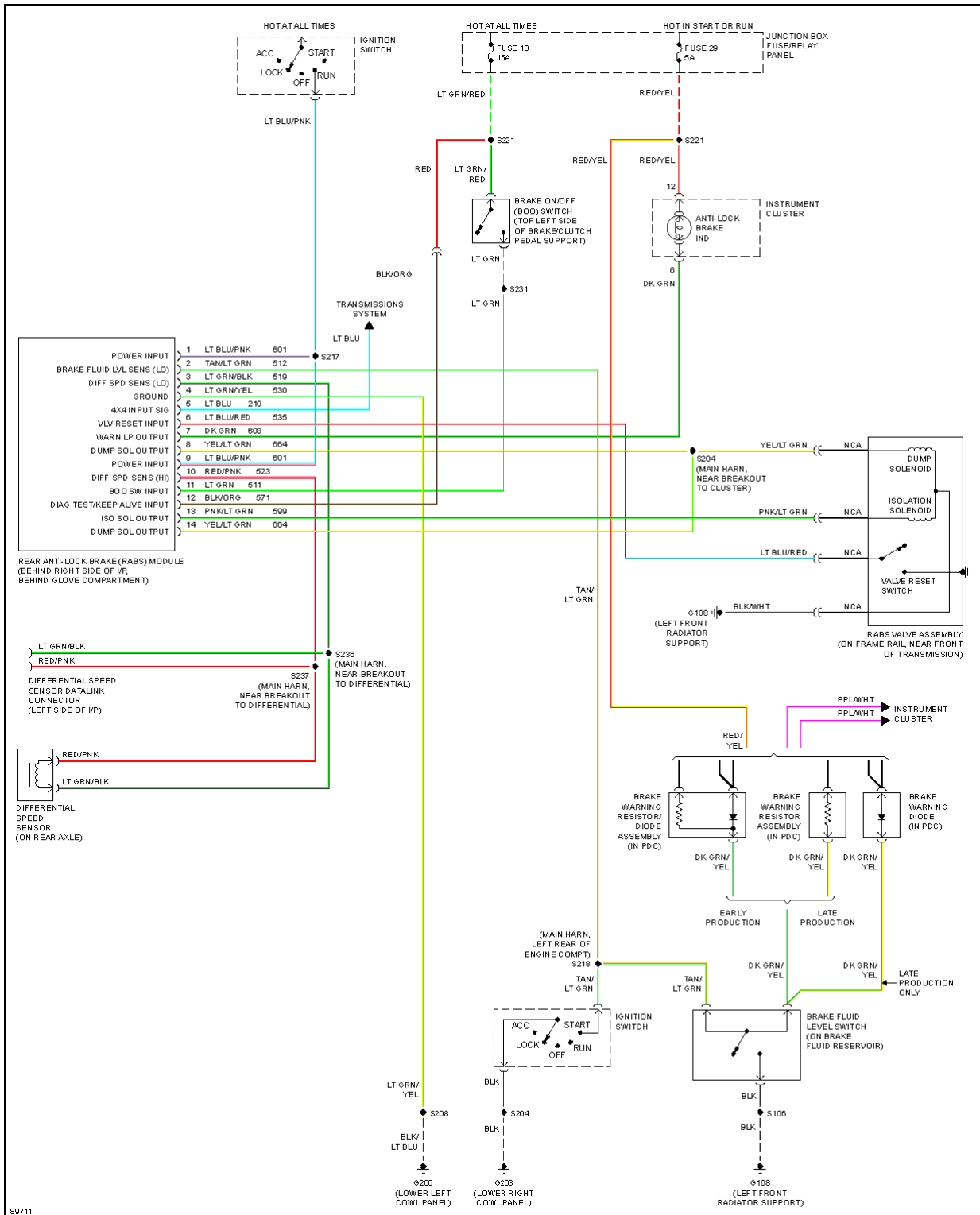

**1997 Ford Pickup F150**

1997 System Wiring Diagrams Ford - Pickup F150

**Fig. 6: Rear Wheel ABS Circuit**

**ANTI-THEFT**

# 1997 Ford Pickup F150

## 1997 System Wiring Diagrams Ford - Pickup F150

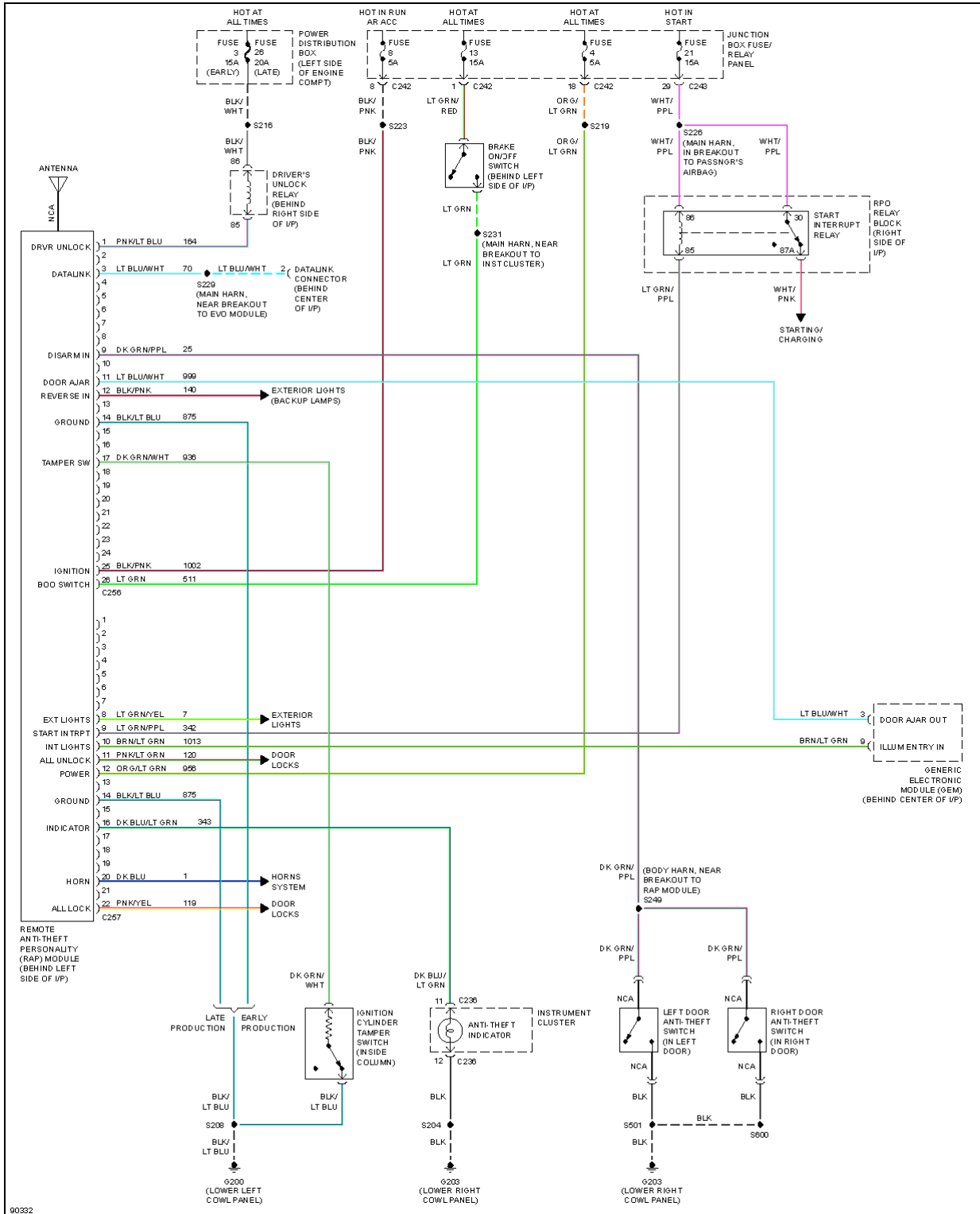

**1997 Ford Pickup F150**

1997 System Wiring Diagrams Ford - Pickup F150

**Fig. 7: Anti-theft Circuit**

**BODY COMPUTER**

# 1997 Ford Pickup F150

## 1997 System Wiring Diagrams Ford - Pickup F150

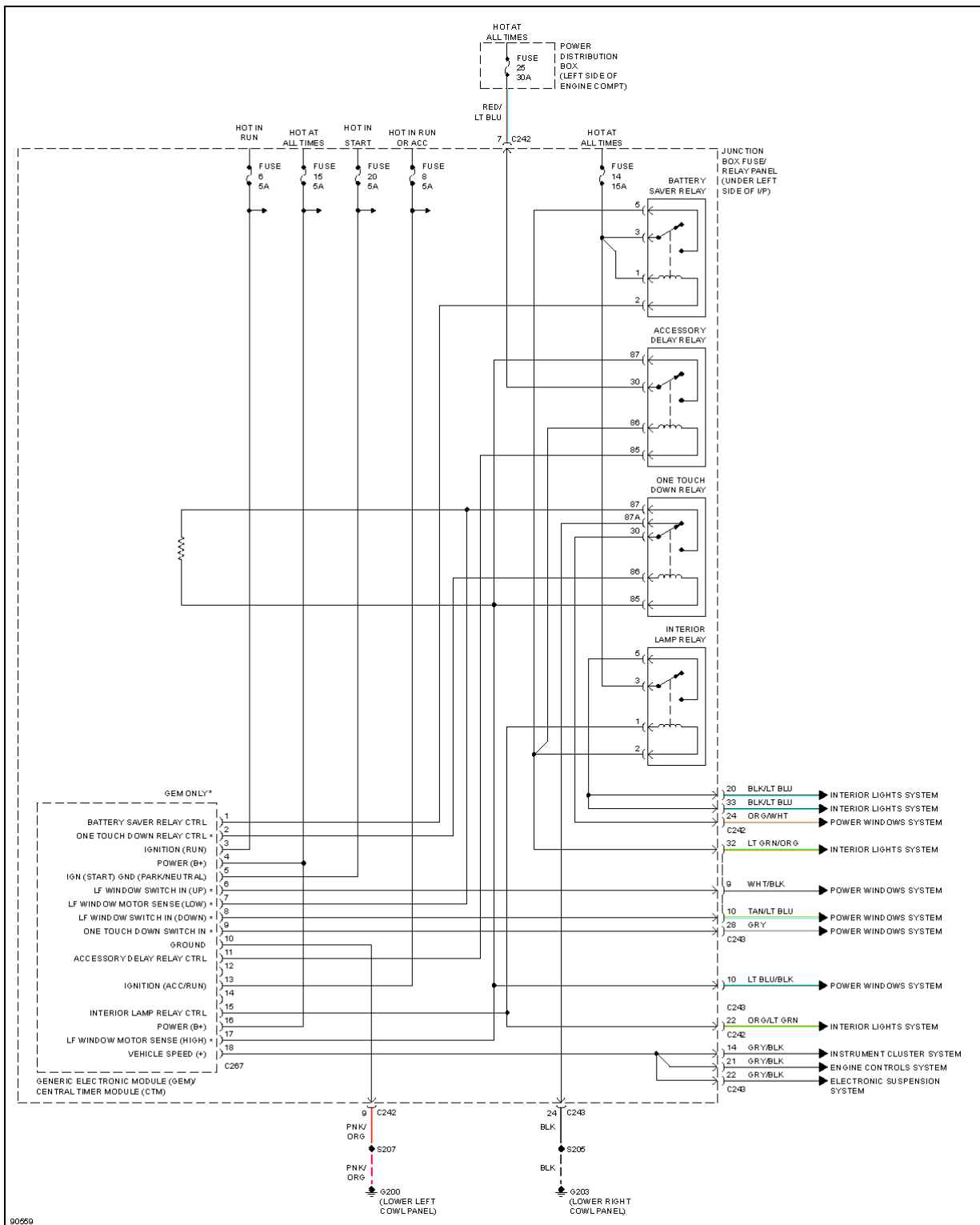



**1997 Ford Pickup F150**

1997 System Wiring Diagrams Ford - Pickup F150

**Fig. 8: Body Computer Circuits (1 of 2)**

# 1997 Ford Pickup F150

## 1997 System Wiring Diagrams Ford - Pickup F150

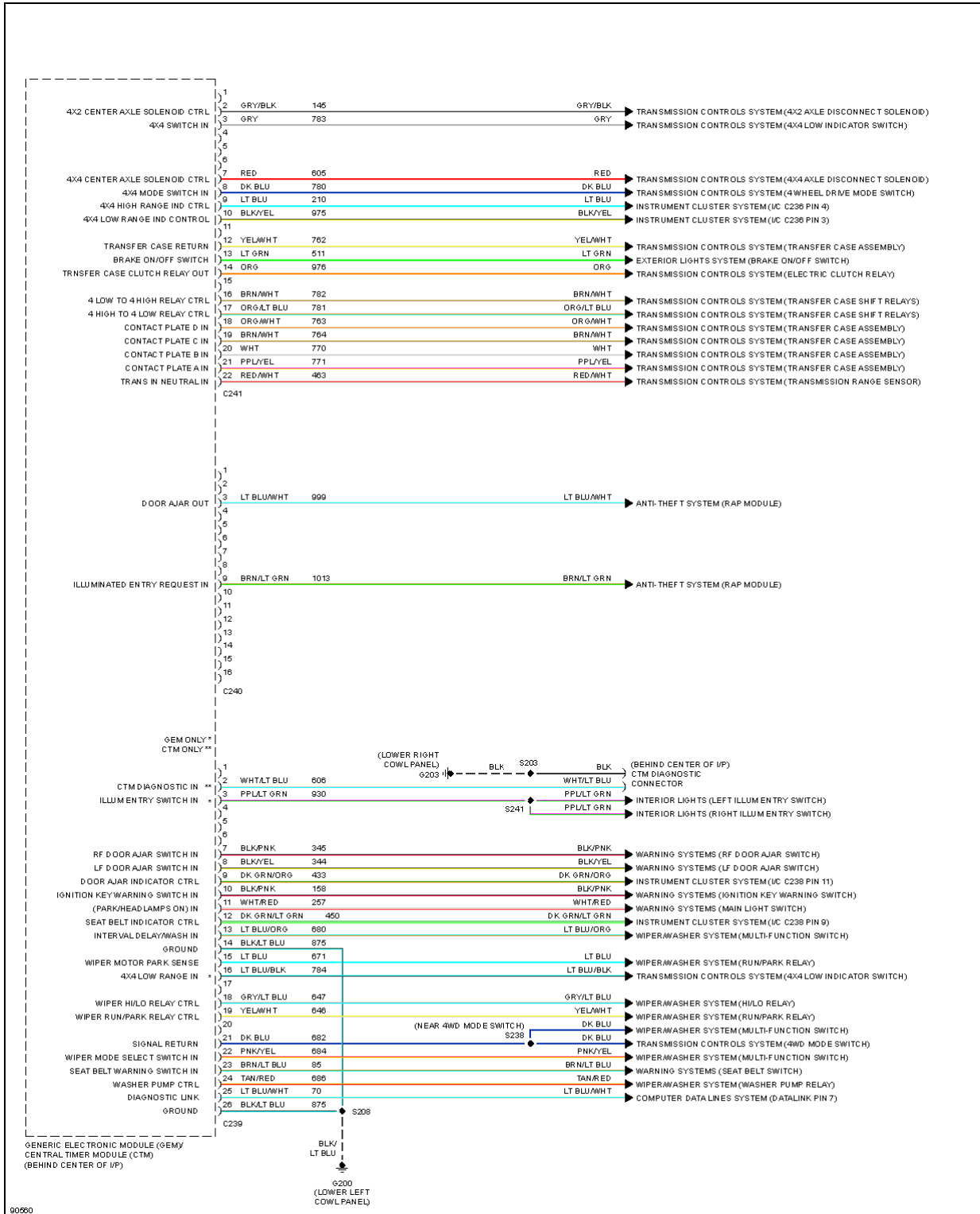
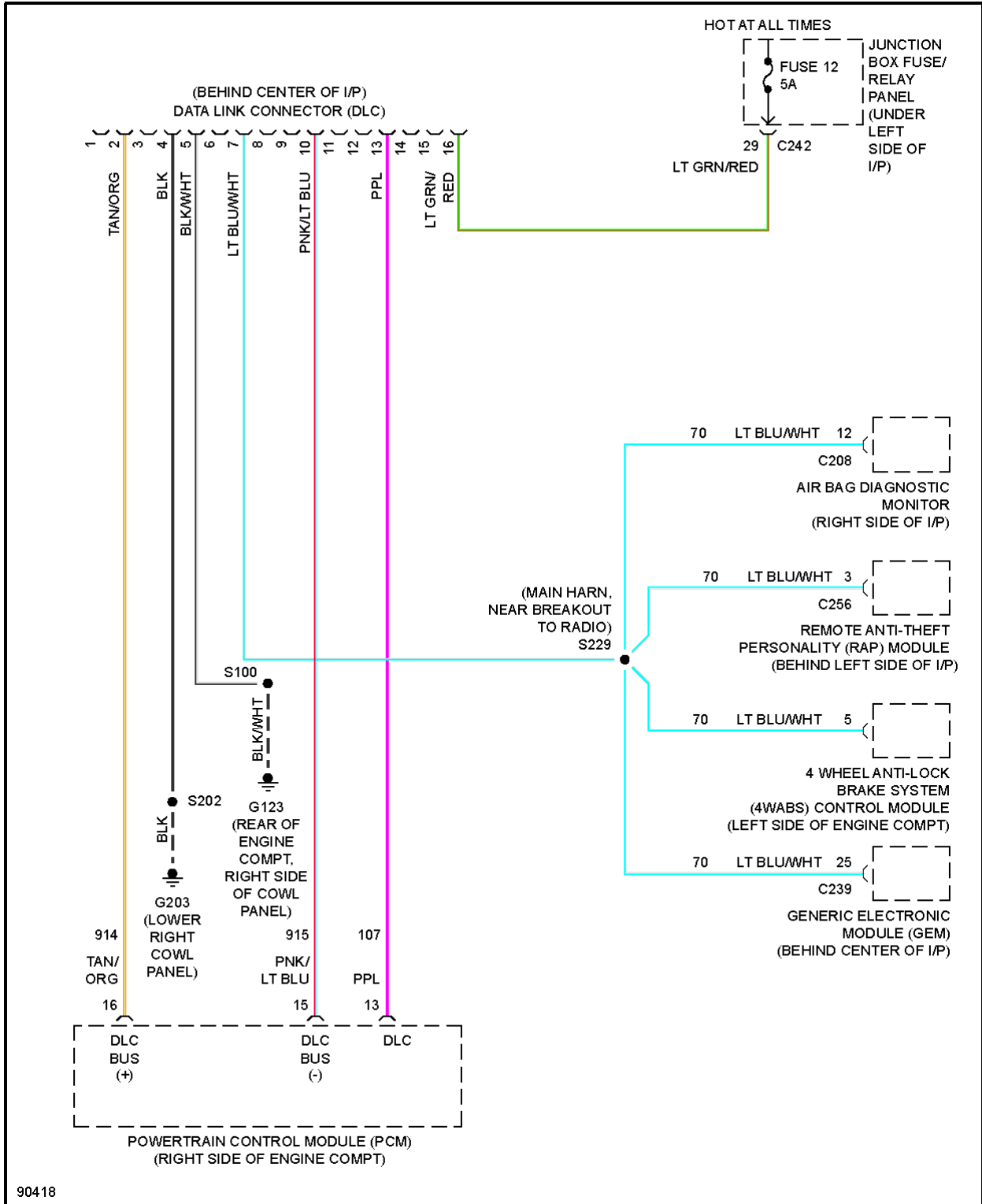

**Fig. 9: Body Computer Circuits (2 of 2)**

## **COMPUTER DATA LINES**

# 1997 Ford Pickup F150

## 1997 System Wiring Diagrams Ford - Pickup F150



**1997 Ford Pickup F150**

1997 System Wiring Diagrams Ford - Pickup F150

**Fig. 10: Computer Data Lines**

**CRUISE CONTROL**

# 1997 Ford Pickup F150

## 1997 System Wiring Diagrams Ford - Pickup F150

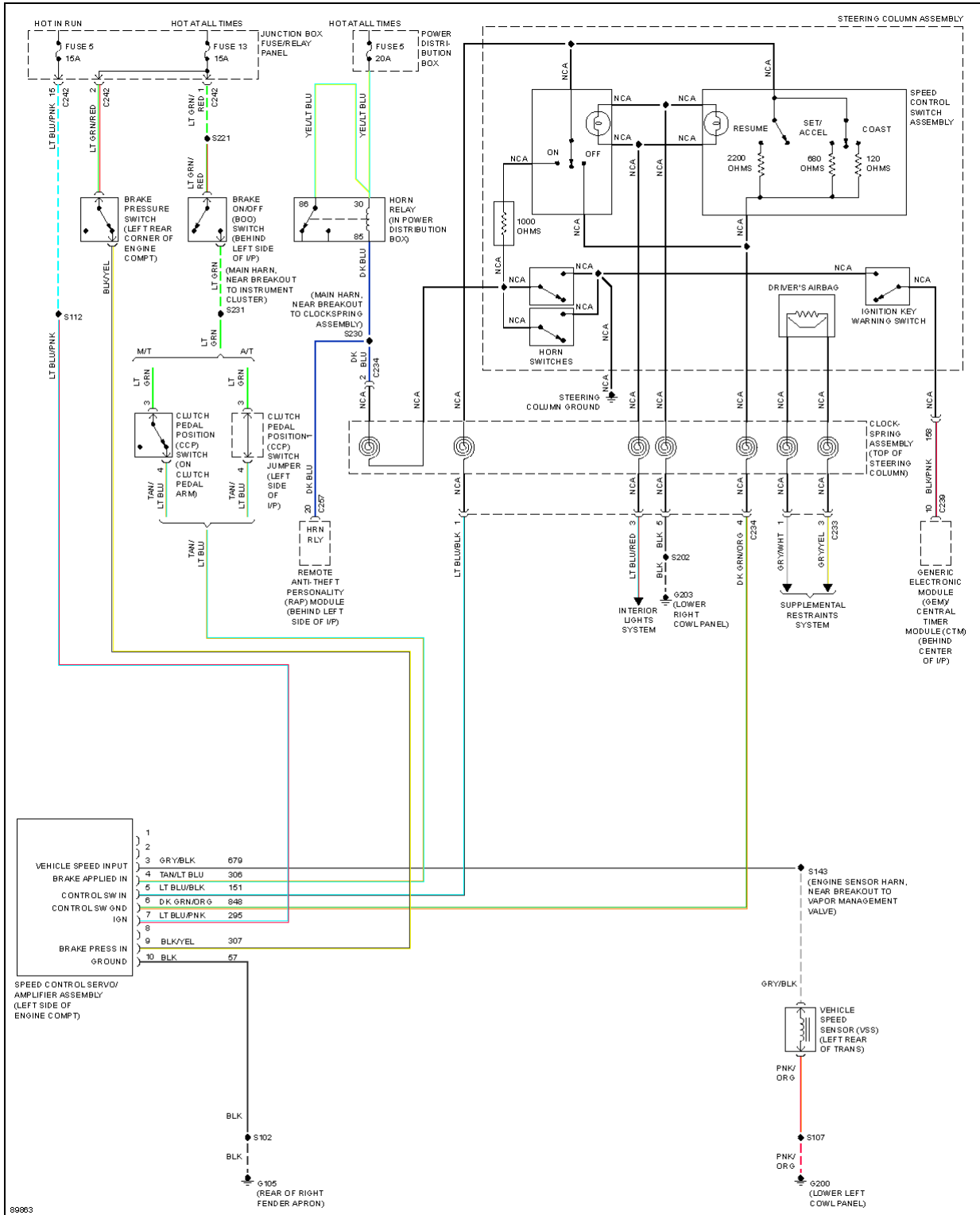
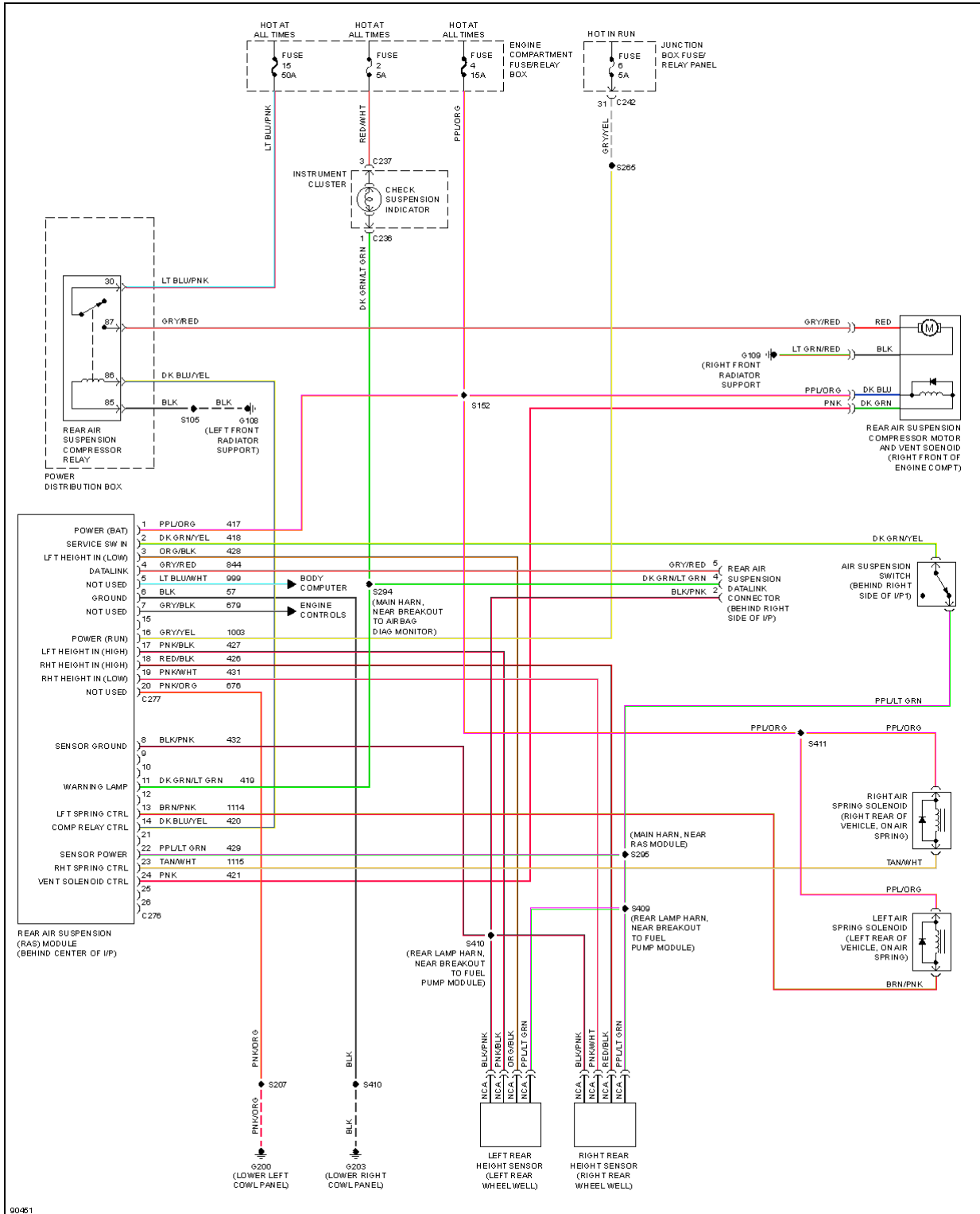

**Fig. 11: Cruise Control Circuit**

## **ELECTRONIC SUSPENSION**

# 1997 Ford Pickup F150

## 1997 System Wiring Diagrams Ford - Pickup F150





**Fig. 12: Electronic Suspension Circuit**

**ENGINE PERFORMANCE**

**4.2L**

# 1997 Ford Pickup F150

## 1997 System Wiring Diagrams Ford - Pickup F150

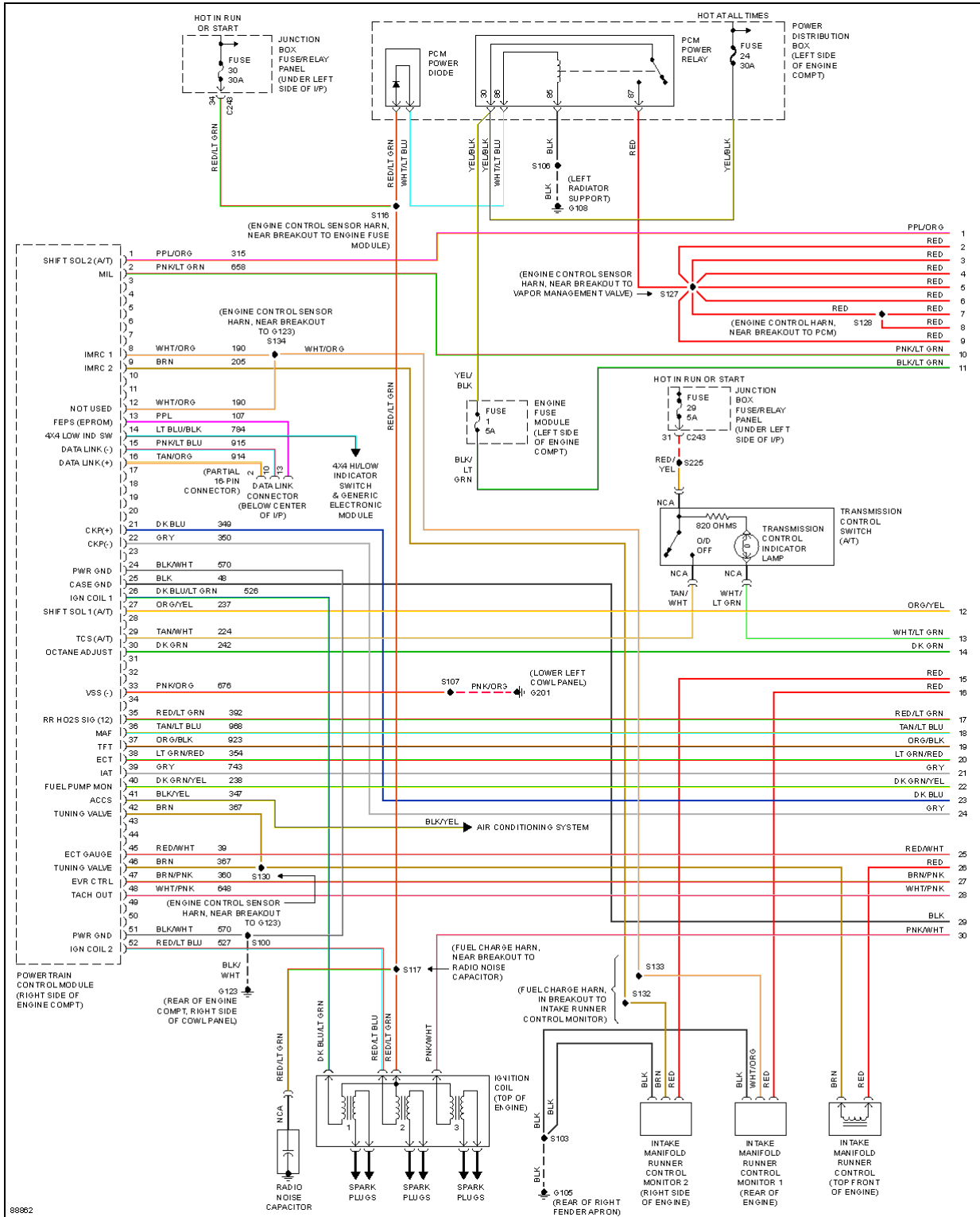

**1997 Ford Pickup F150**

1997 System Wiring Diagrams Ford - Pickup F150

**Fig. 13: 4.2L, Engine Performance Circuits, Early Production (1 of 4)**



**1997 Ford Pickup F150**

1997 System Wiring Diagrams Ford - Pickup F150

**Fig. 14: 4.2L, Engine Performance Circuits, Early Production (2 of 4)**

# 1997 Ford Pickup F150

## 1997 System Wiring Diagrams Ford - Pickup F150

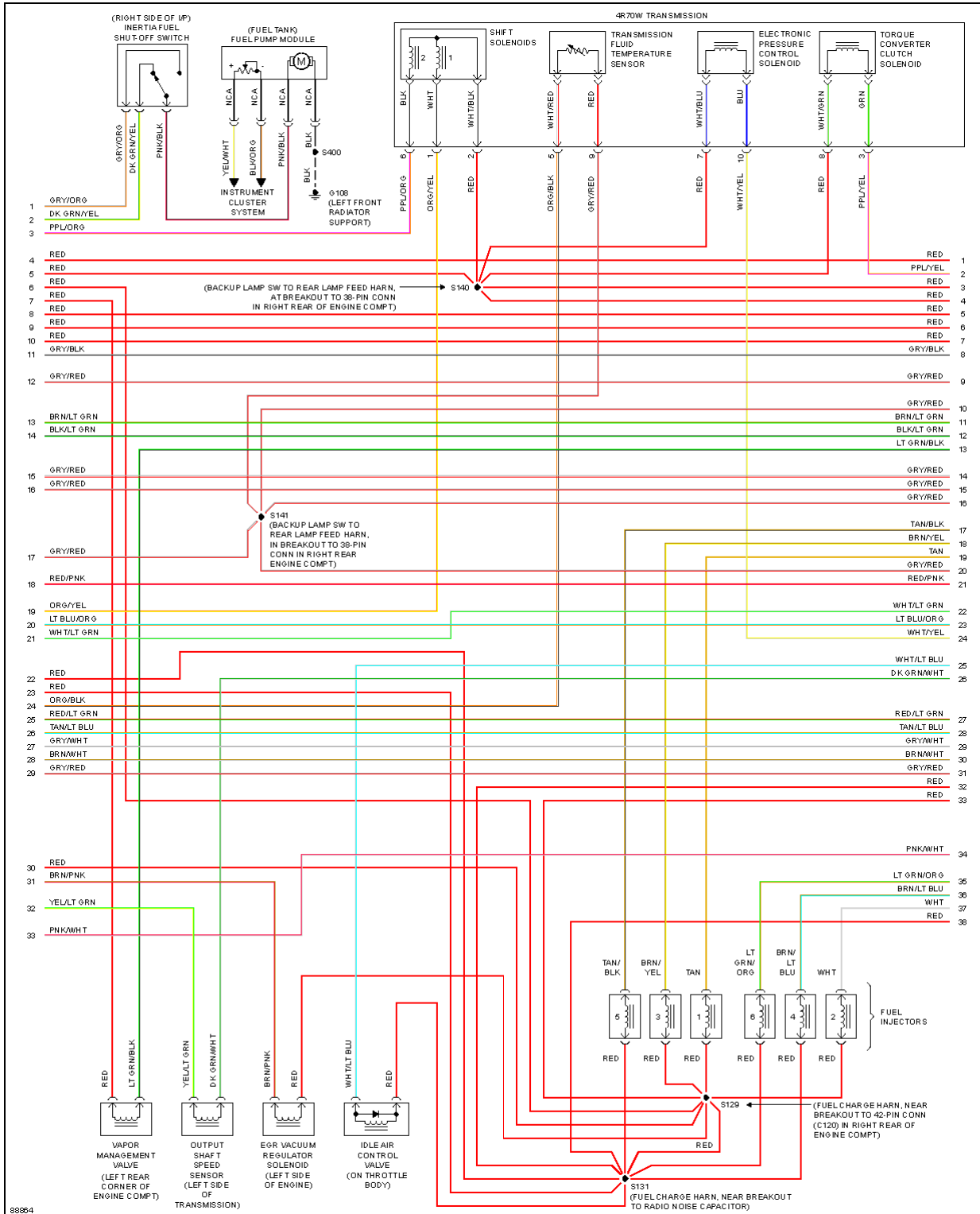

**1997 Ford Pickup F150**

1997 System Wiring Diagrams Ford - Pickup F150

**Fig. 15: 4.2L, Engine Performance Circuits, Early Production (3 of 4)**

# 1997 Ford Pickup F150

## 1997 System Wiring Diagrams Ford - Pickup F150

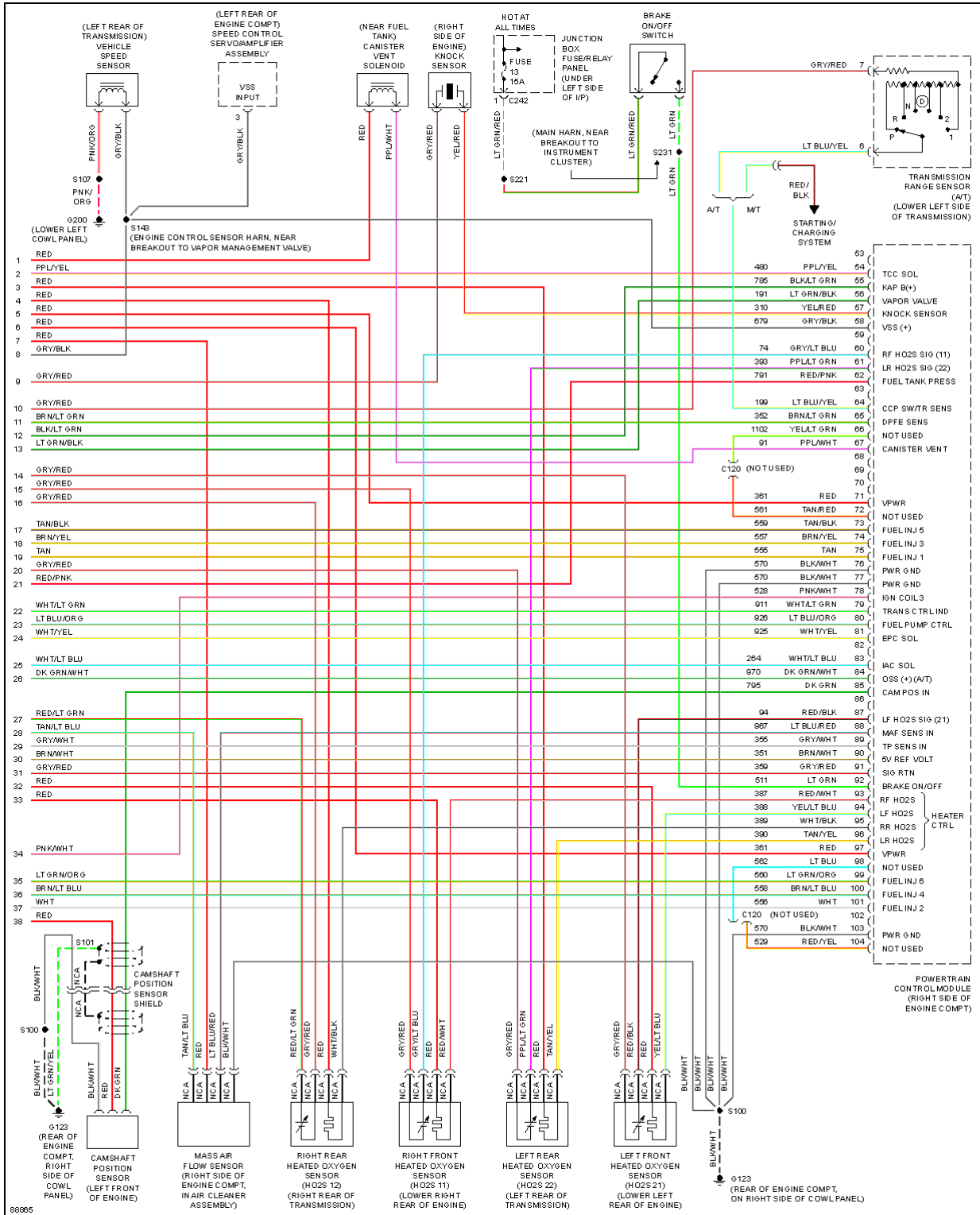



**1997 Ford Pickup F150**

1997 System Wiring Diagrams Ford - Pickup F150

**Fig. 16: 4.2L, Engine Performance Circuits, Early Production (4 of 4)**

# 1997 Ford Pickup F150

## 1997 System Wiring Diagrams Ford - Pickup F150

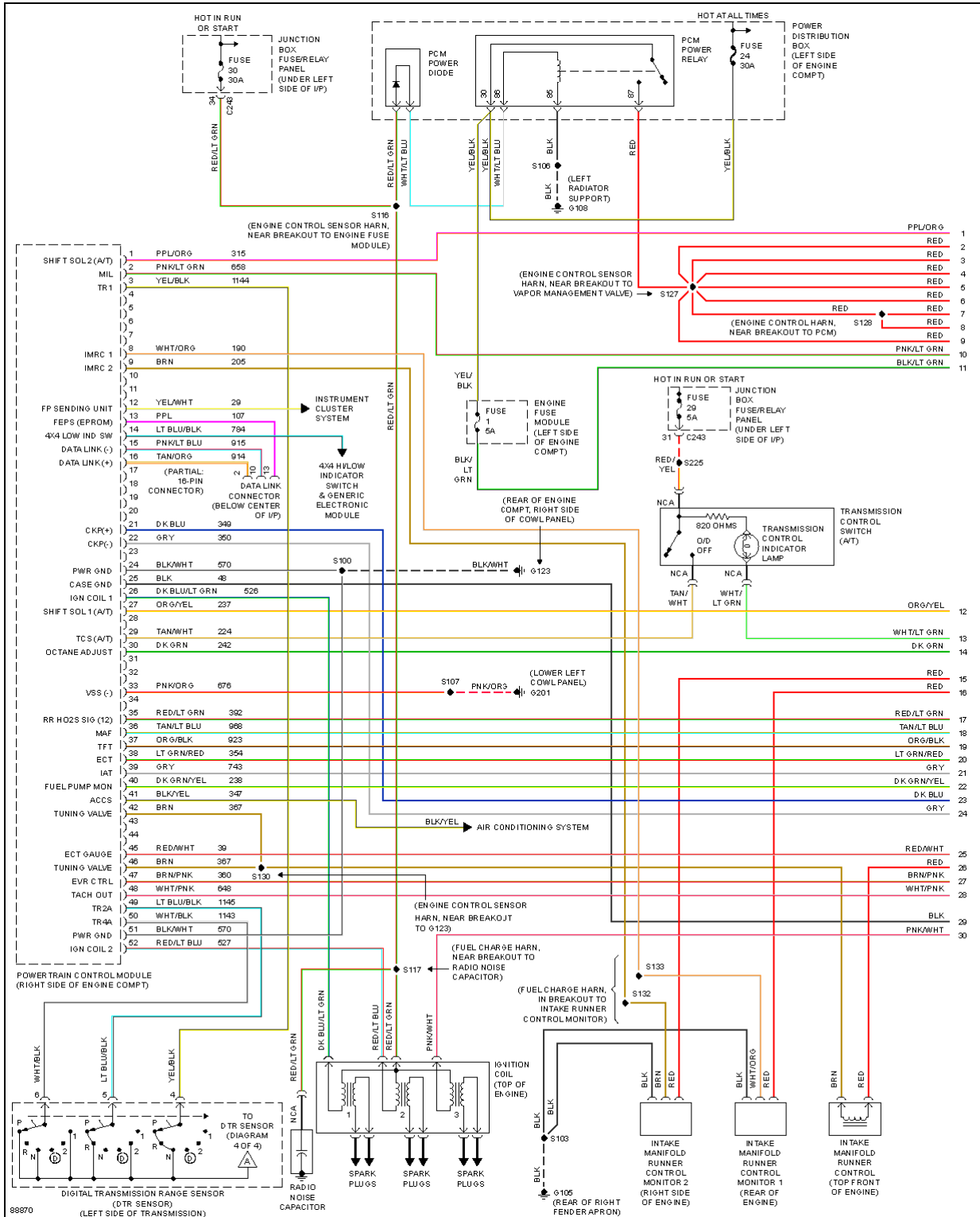

**1997 Ford Pickup F150**

1997 System Wiring Diagrams Ford - Pickup F150

**Fig. 17: 4.2L, Engine Performance Circuits, Late Production (1 of 4)**

# 1997 Ford Pickup F150

## 1997 System Wiring Diagrams Ford - Pickup F150

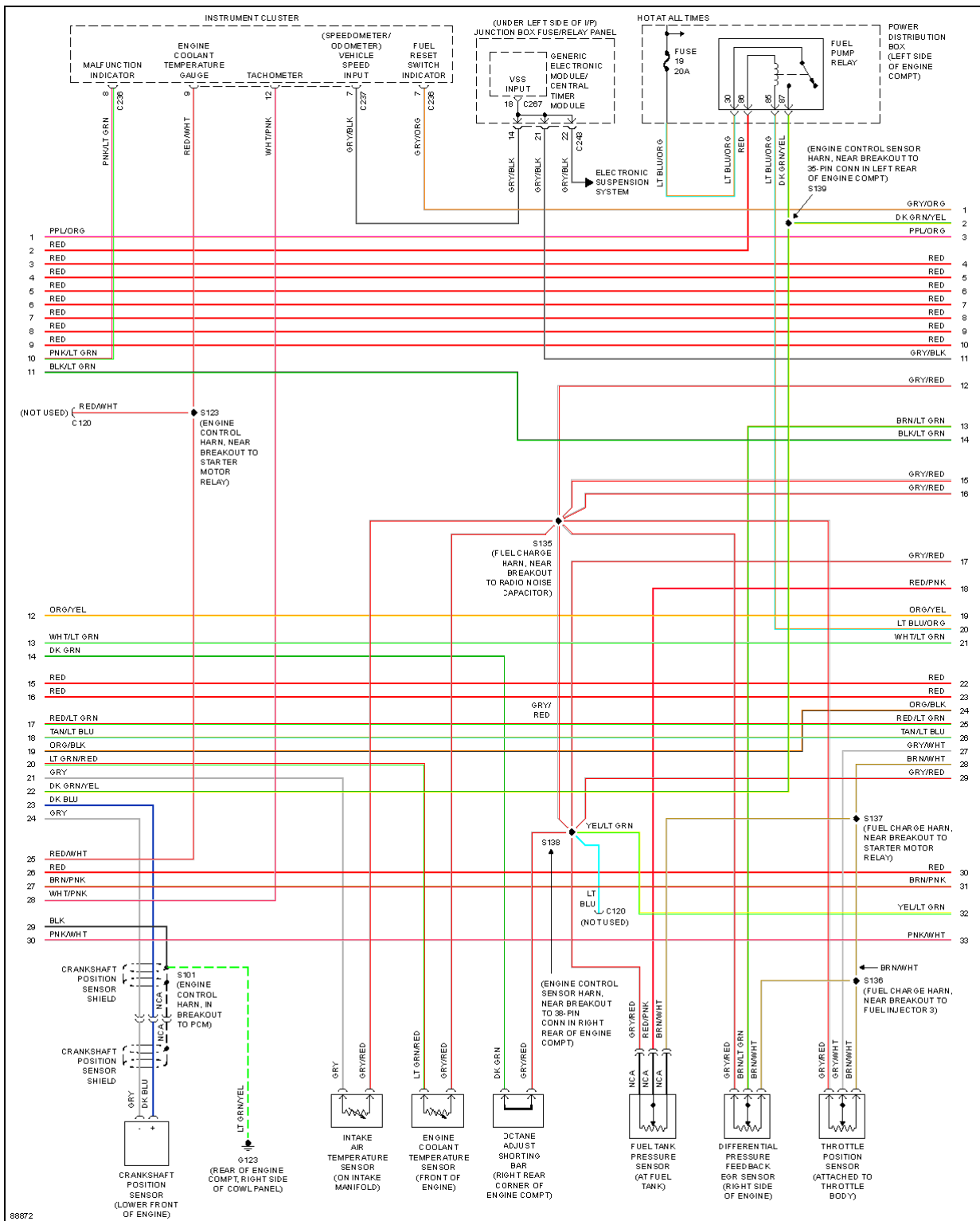

**1997 Ford Pickup F150**

1997 System Wiring Diagrams Ford - Pickup F150

**Fig. 18: 4.2L, Engine Performance Circuits, Late Production (2 of 4)**

# 1997 Ford Pickup F150

## 1997 System Wiring Diagrams Ford - Pickup F150

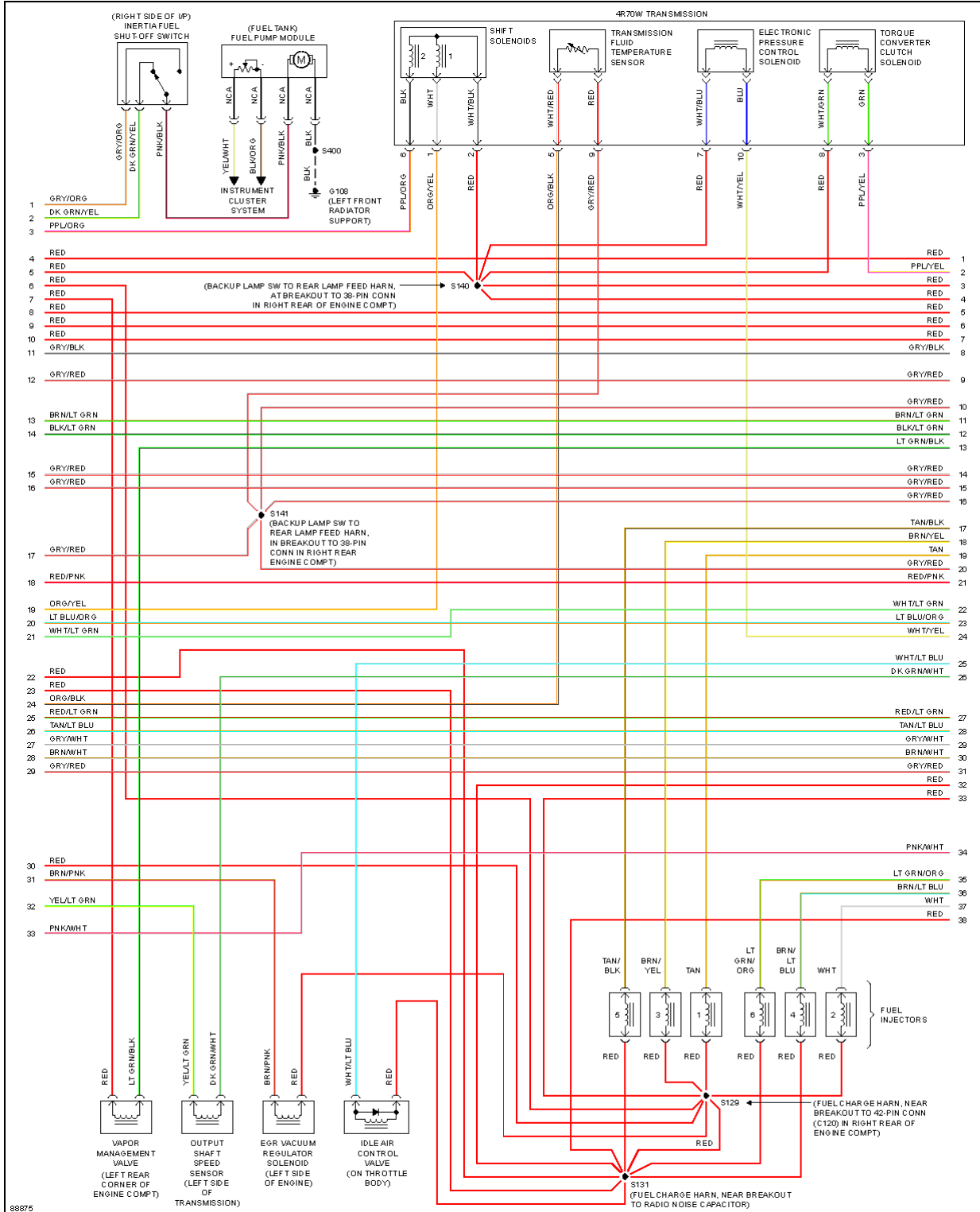

**1997 Ford Pickup F150**

1997 System Wiring Diagrams Ford - Pickup F150

**Fig. 19: 4.2L, Engine Performance Circuits, Late Production (3 of 4)**

# 1997 Ford Pickup F150

## 1997 System Wiring Diagrams Ford - Pickup F150

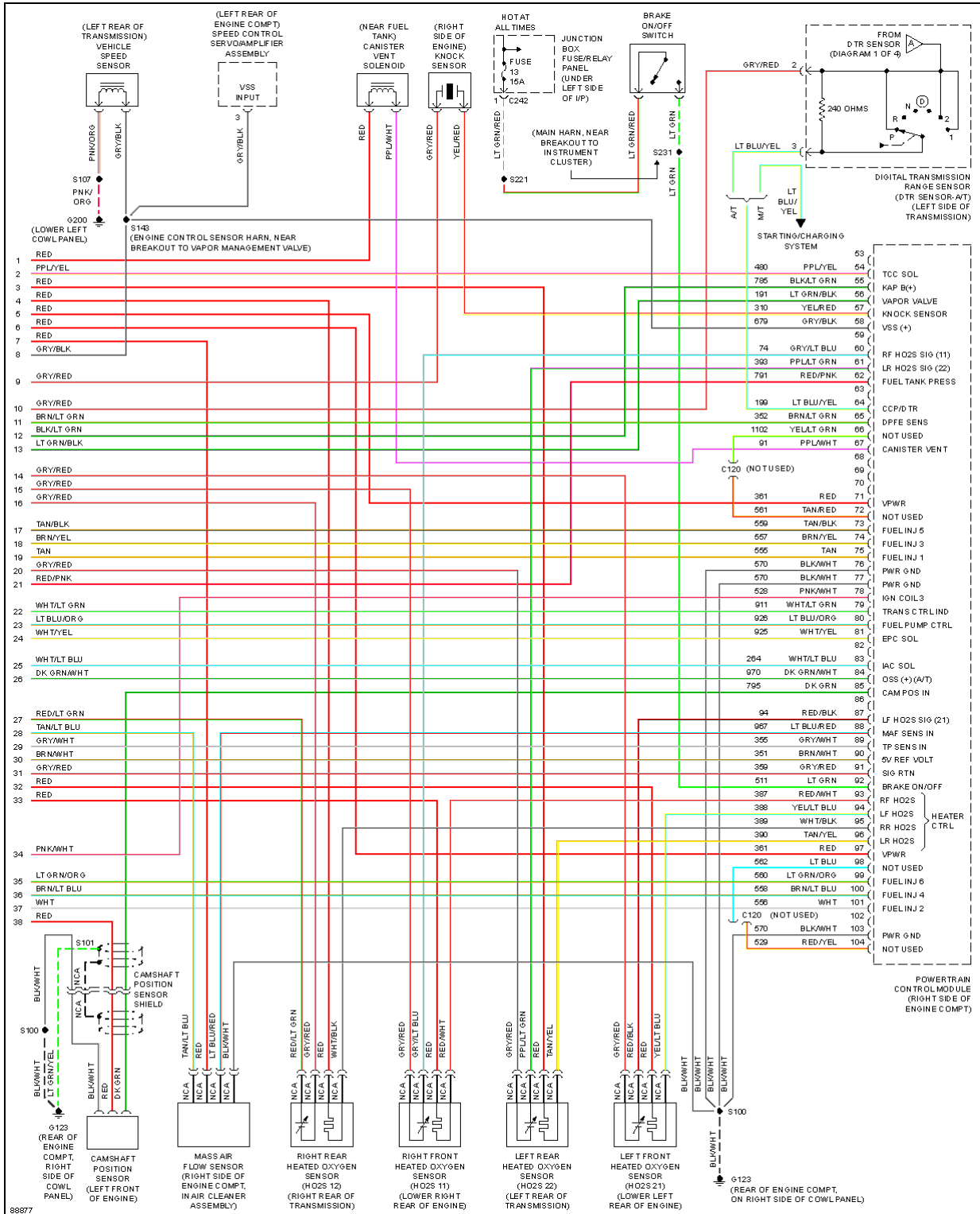



**1997 Ford Pickup F150**

1997 System Wiring Diagrams Ford - Pickup F150

**Fig. 20: 4.2L, Engine Performance Circuits, Late Production (4 of 4)**

**4.6L**

# 1997 Ford Pickup F150

## 1997 System Wiring Diagrams Ford - Pickup F150

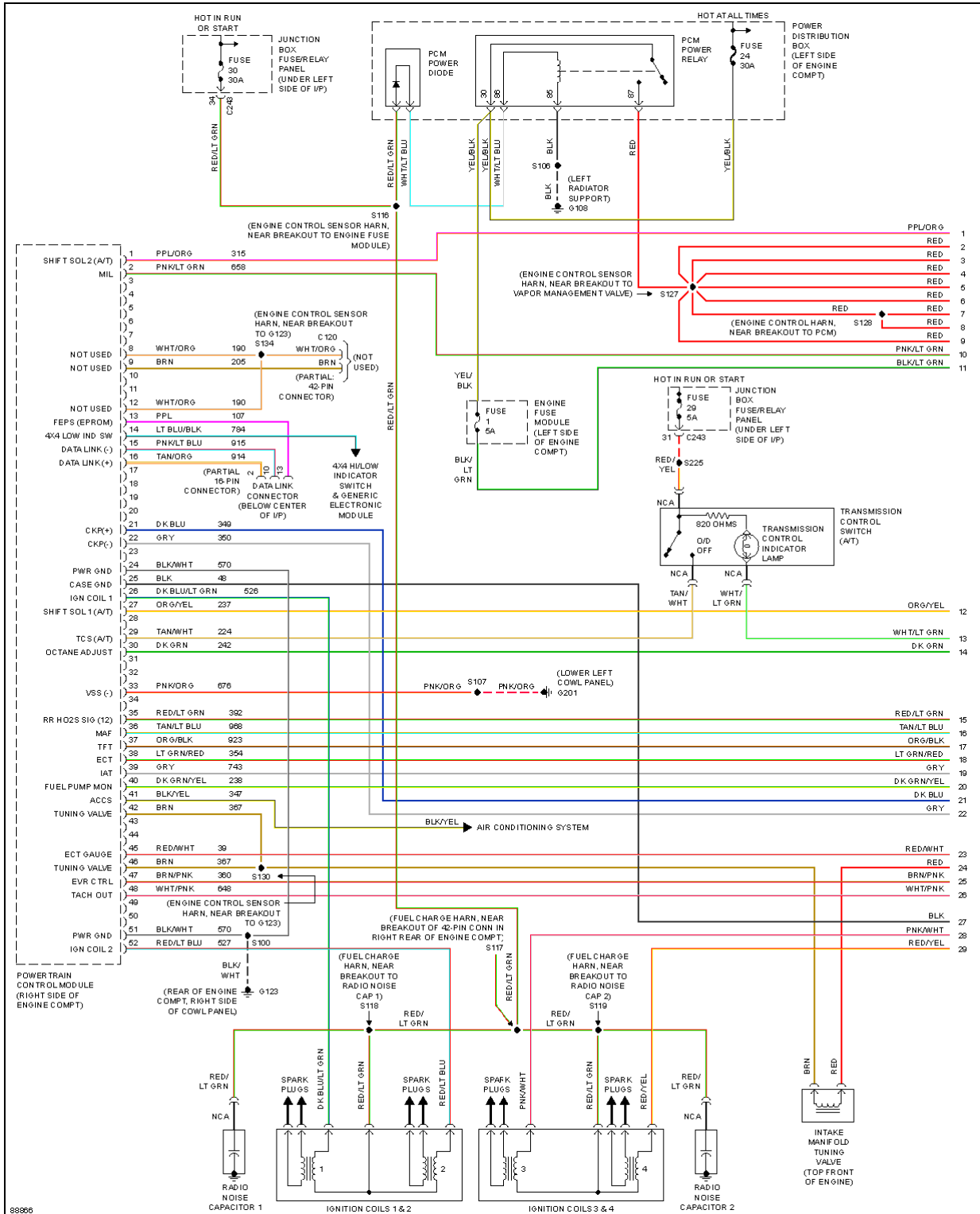

**1997 Ford Pickup F150**

1997 System Wiring Diagrams Ford - Pickup F150

**Fig. 21: 4.6L, Engine Performance Circuits, Early Production (1 of 4)**

# 1997 Ford Pickup F150

## 1997 System Wiring Diagrams Ford - Pickup F150

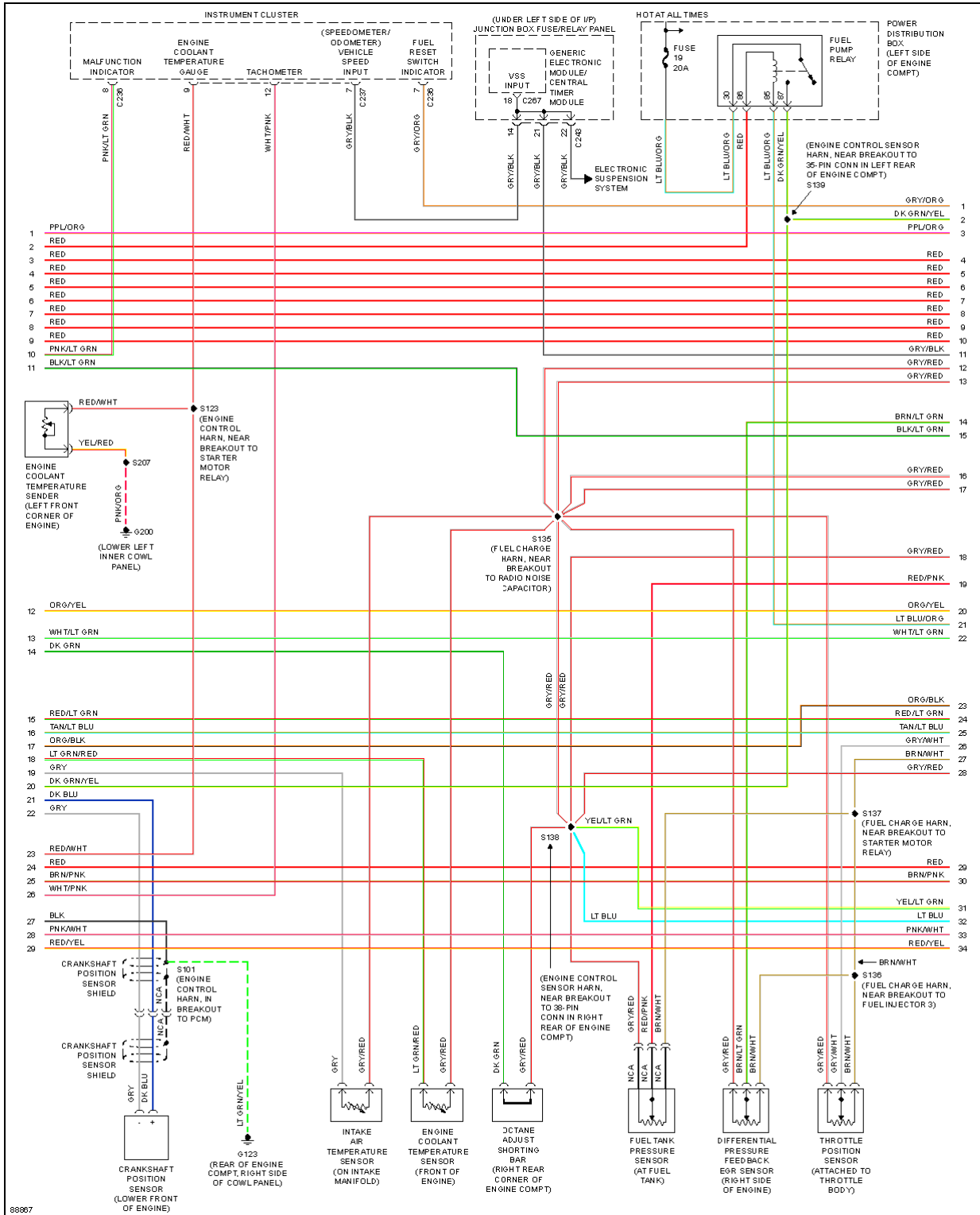

**1997 Ford Pickup F150**

1997 System Wiring Diagrams Ford - Pickup F150

**Fig. 22: 4.6L, Engine Performance Circuits, Early Production (2 of 4)**

# 1997 Ford Pickup F150

## 1997 System Wiring Diagrams Ford - Pickup F150

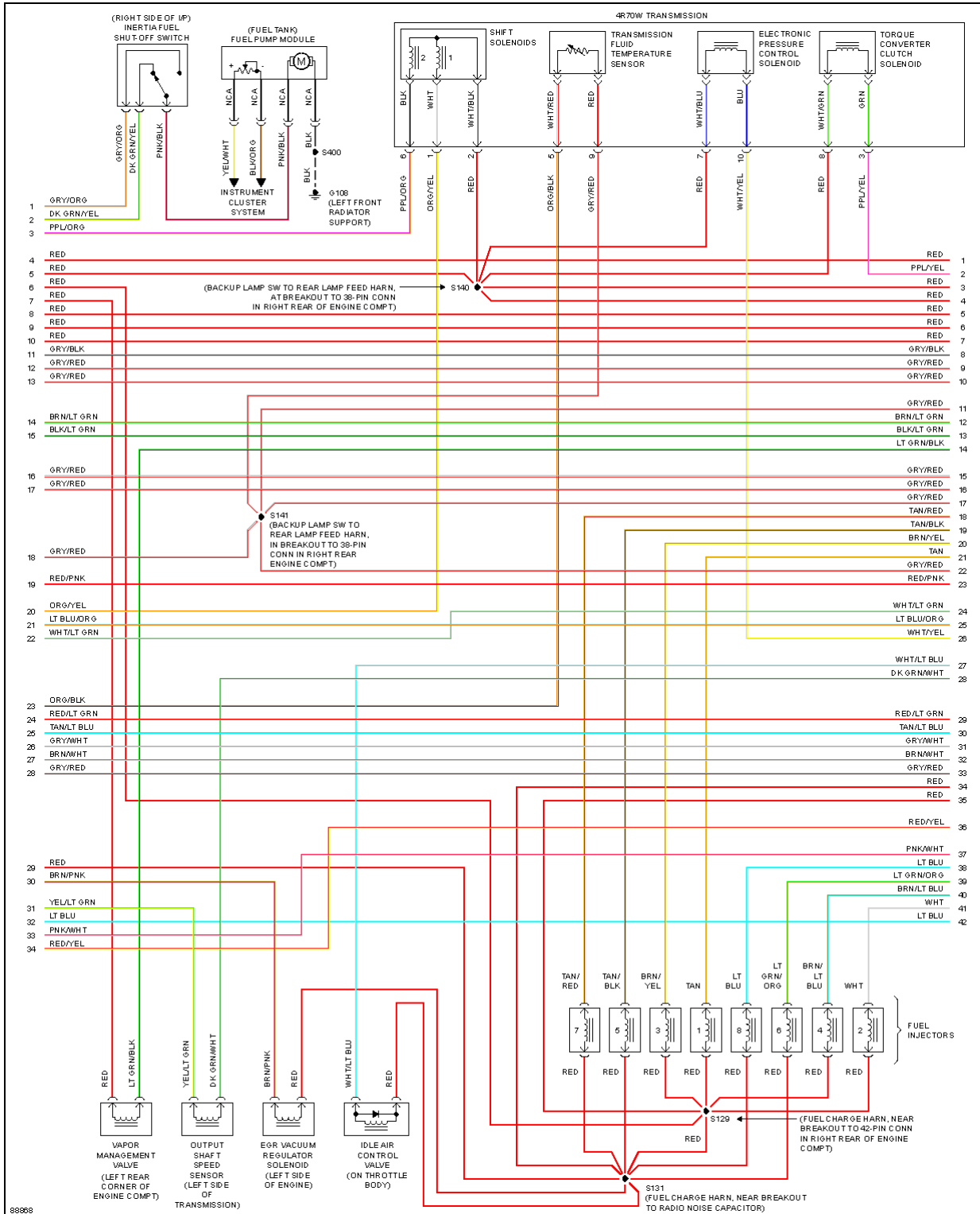

**1997 Ford Pickup F150**

1997 System Wiring Diagrams Ford - Pickup F150

**Fig. 23: 4.6L, Engine Performance Circuits, Early Production (3 of 4)**

# 1997 Ford Pickup F150

## 1997 System Wiring Diagrams Ford - Pickup F150

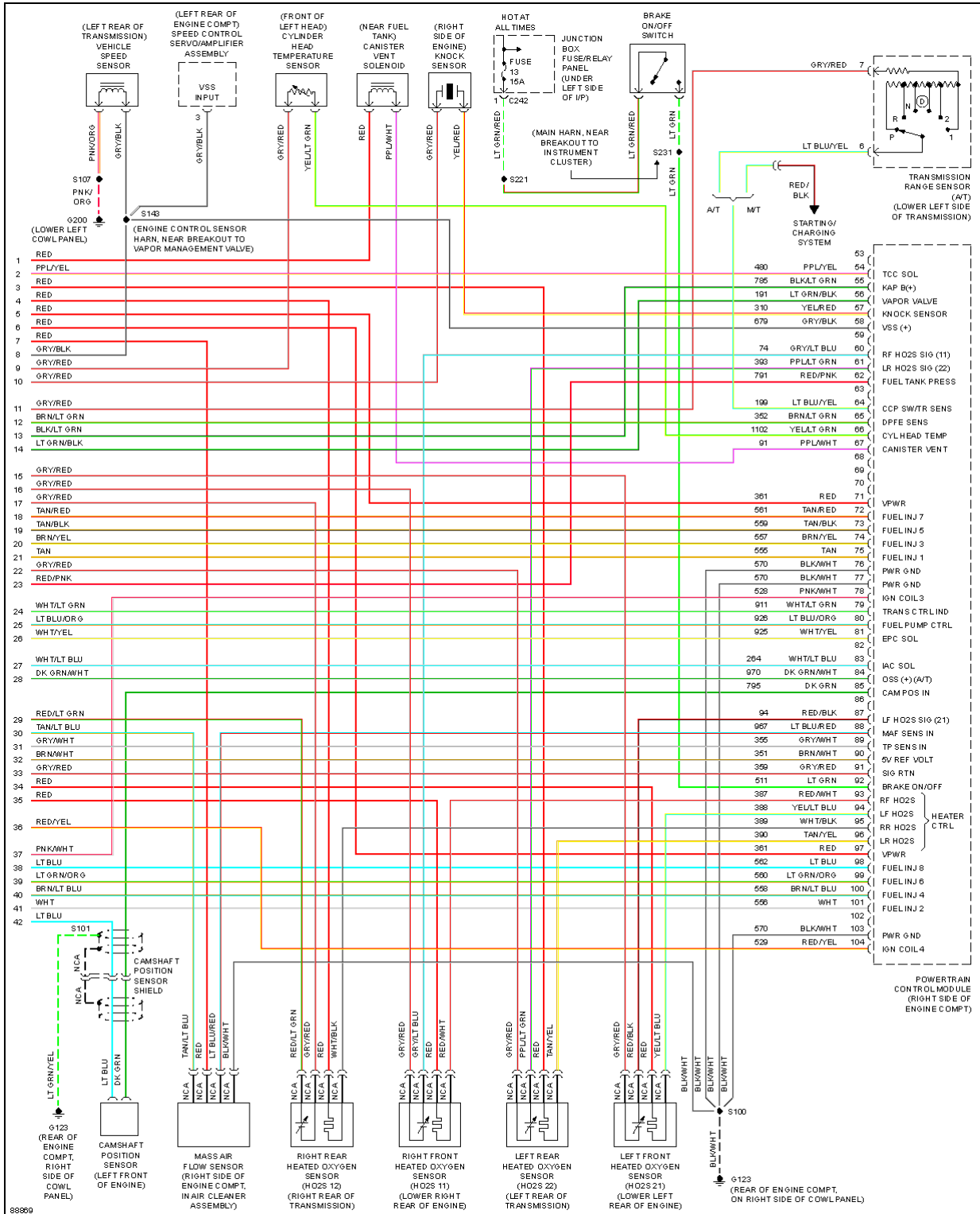



**1997 Ford Pickup F150**

1997 System Wiring Diagrams Ford - Pickup F150

**Fig. 24: 4.6L, Engine Performance Circuits, Early Production (4 of 4)**

# 1997 Ford Pickup F150

## 1997 System Wiring Diagrams Ford - Pickup F150

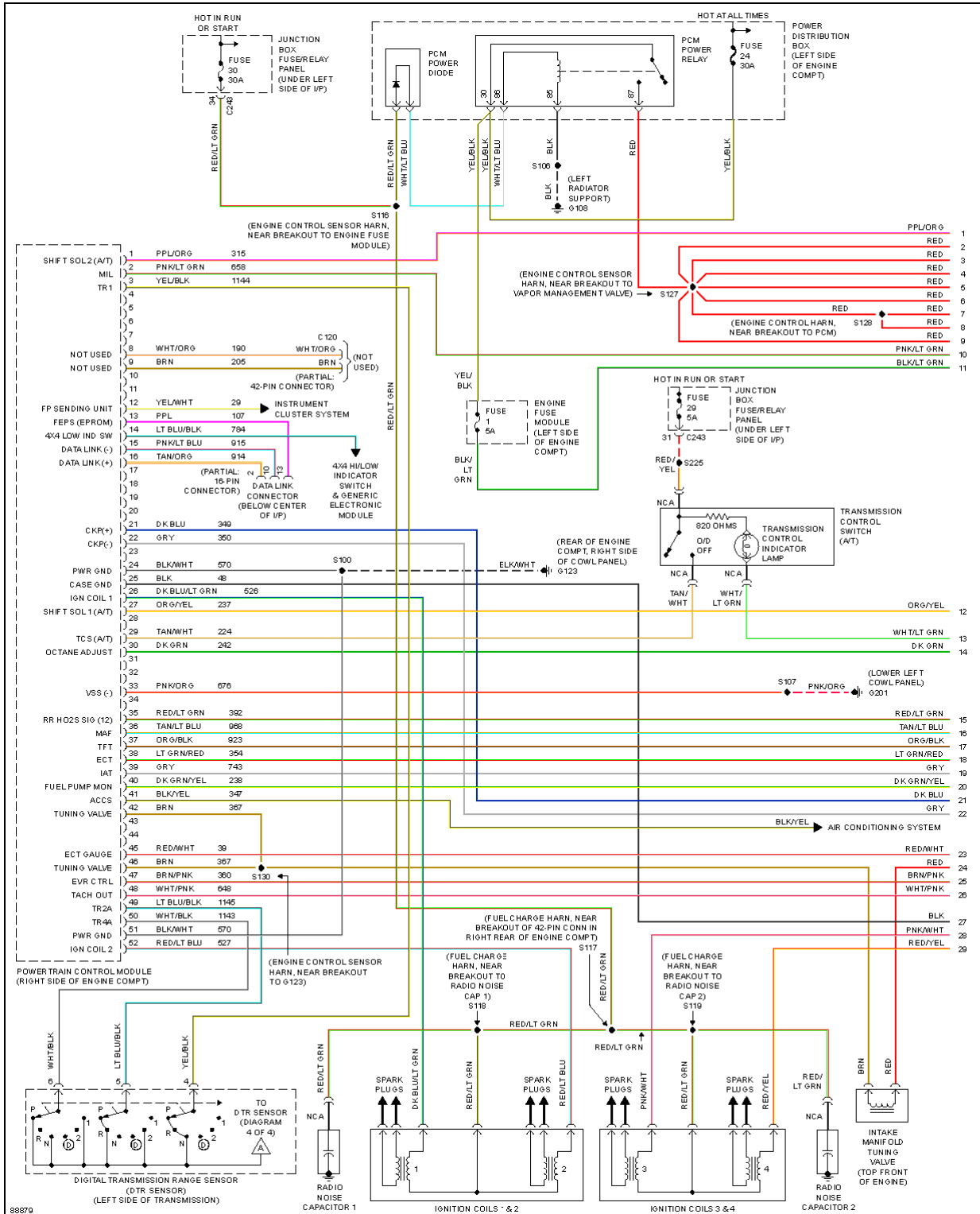

**1997 Ford Pickup F150**

1997 System Wiring Diagrams Ford - Pickup F150

**Fig. 25: 4.6L, Engine Performance Circuits, Late Production (1 of 4)**

# 1997 Ford Pickup F150

## 1997 System Wiring Diagrams Ford - Pickup F150

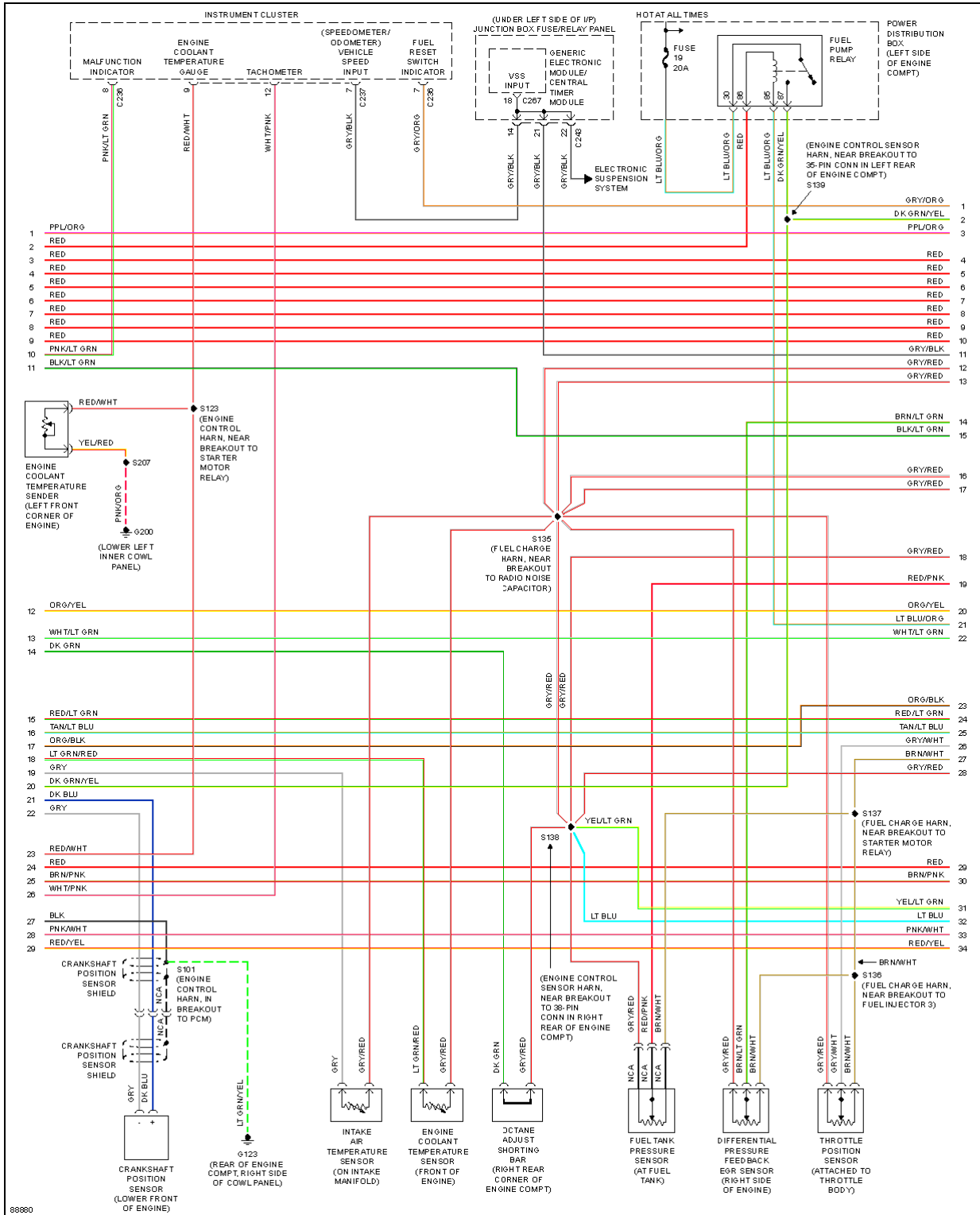

**1997 Ford Pickup F150**

1997 System Wiring Diagrams Ford - Pickup F150

**Fig. 26: 4.6L, Engine Performance Circuits, Late Production (2 of 4)**

# 1997 Ford Pickup F150

## 1997 System Wiring Diagrams Ford - Pickup F150

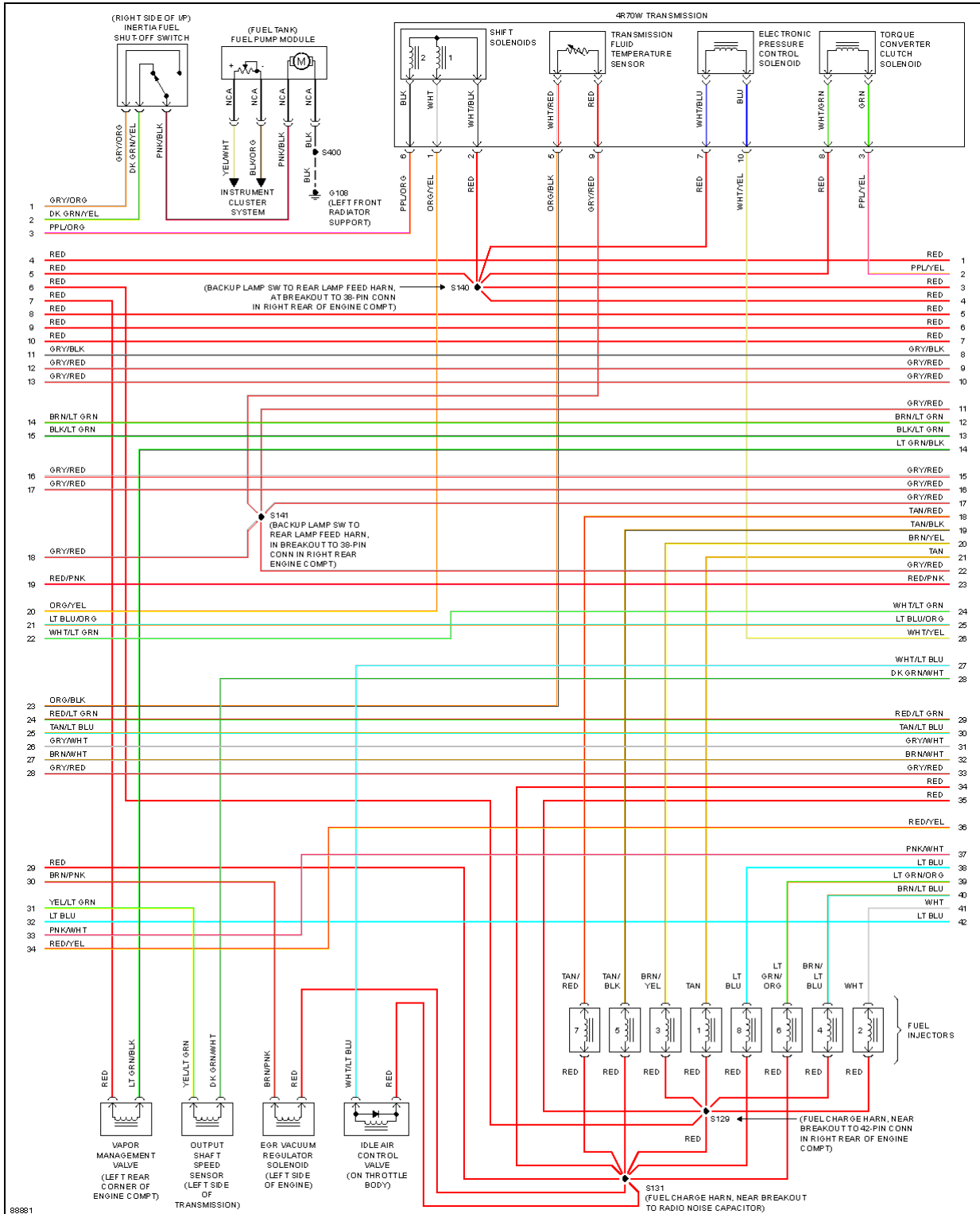

**1997 Ford Pickup F150**

1997 System Wiring Diagrams Ford - Pickup F150

**Fig. 27: 4.6L, Engine Performance Circuits, Late Production (3 of 4)**

# 1997 Ford Pickup F150

## 1997 System Wiring Diagrams Ford - Pickup F150

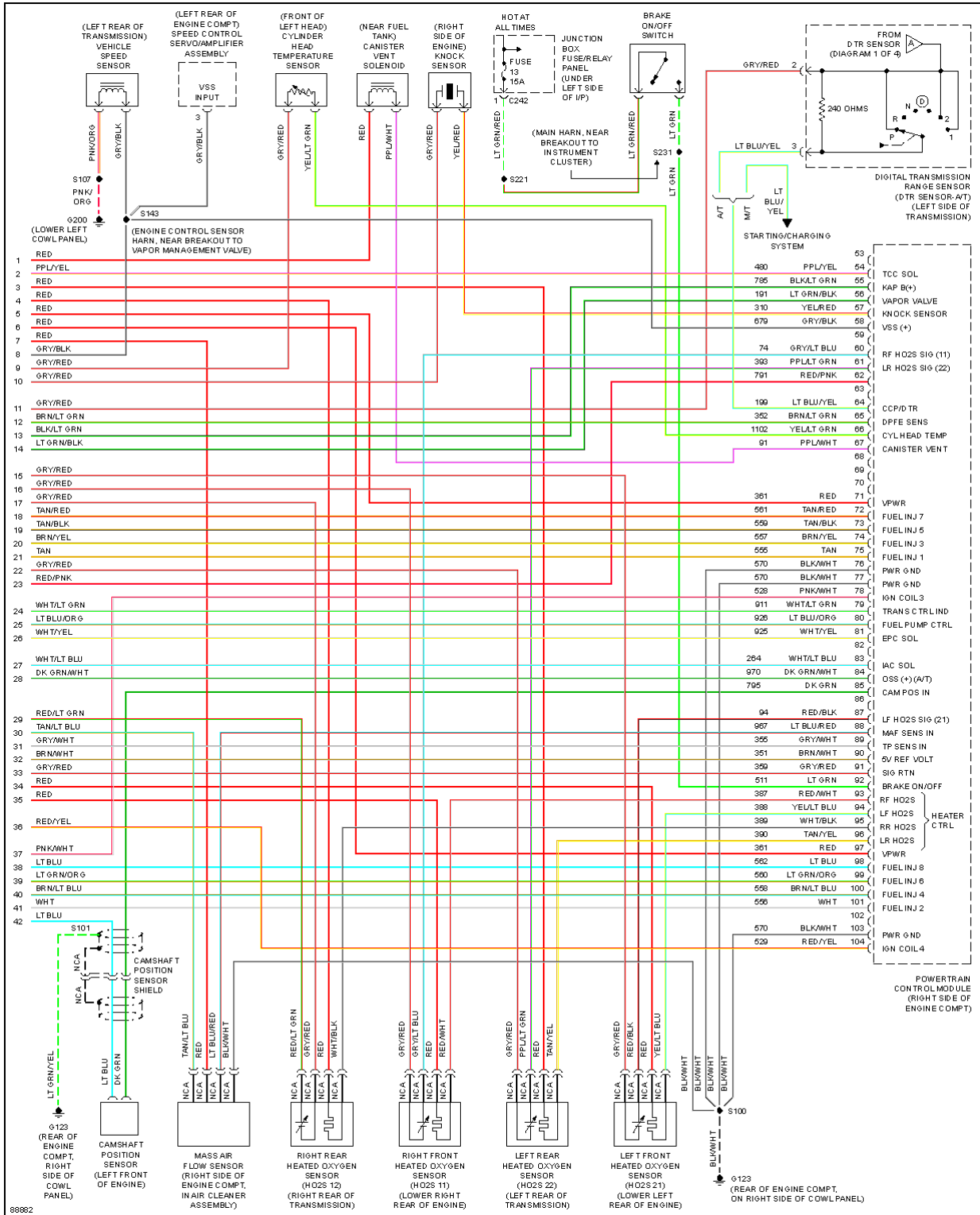



**1997 Ford Pickup F150**

1997 System Wiring Diagrams Ford - Pickup F150

**Fig. 28: 4.6L, Engine Performance Circuits, Late Production (4 of 4)**

**5.4L**

# 1997 Ford Pickup F150

## 1997 System Wiring Diagrams Ford - Pickup F150

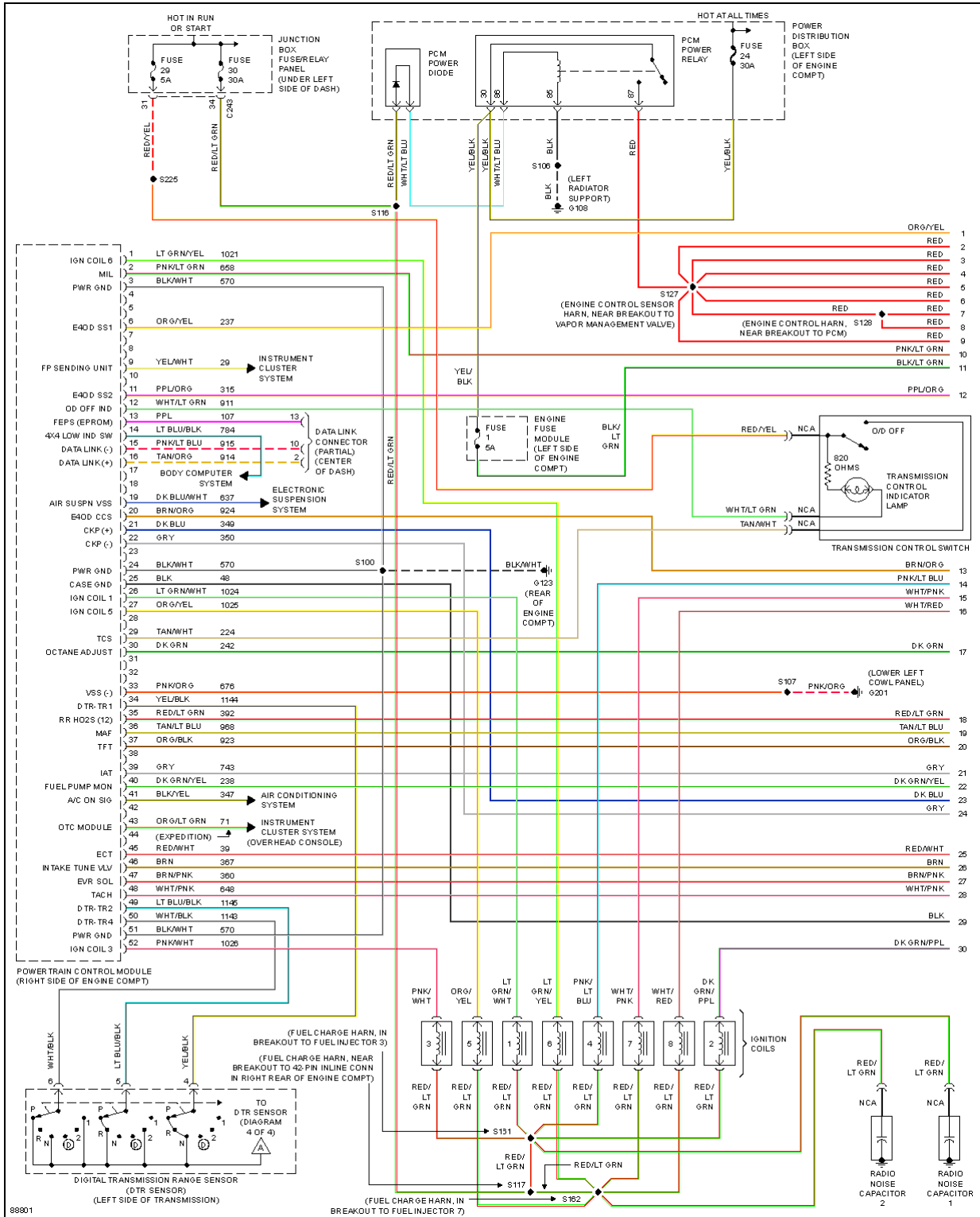

**1997 Ford Pickup F150**

1997 System Wiring Diagrams Ford - Pickup F150

**Fig. 29: 5.4L, Engine Performance Circuits (1 of 4)**

# 1997 Ford Pickup F150

## 1997 System Wiring Diagrams Ford - Pickup F150

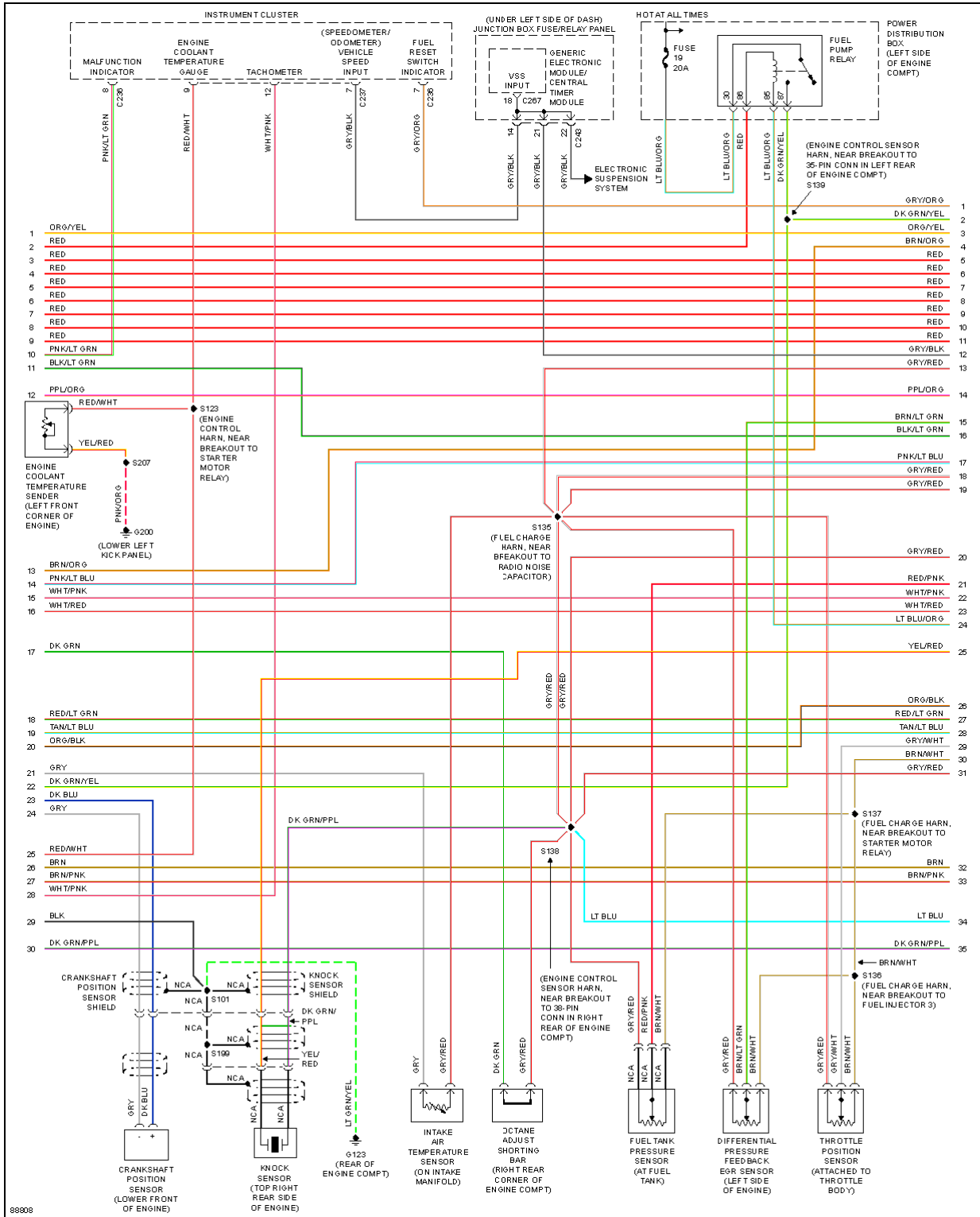

**1997 Ford Pickup F150**

1997 System Wiring Diagrams Ford - Pickup F150

**Fig. 30: 5.4L, Engine Performance Circuits (2 of 4)**

# 1997 Ford Pickup F150

## 1997 System Wiring Diagrams Ford - Pickup F150

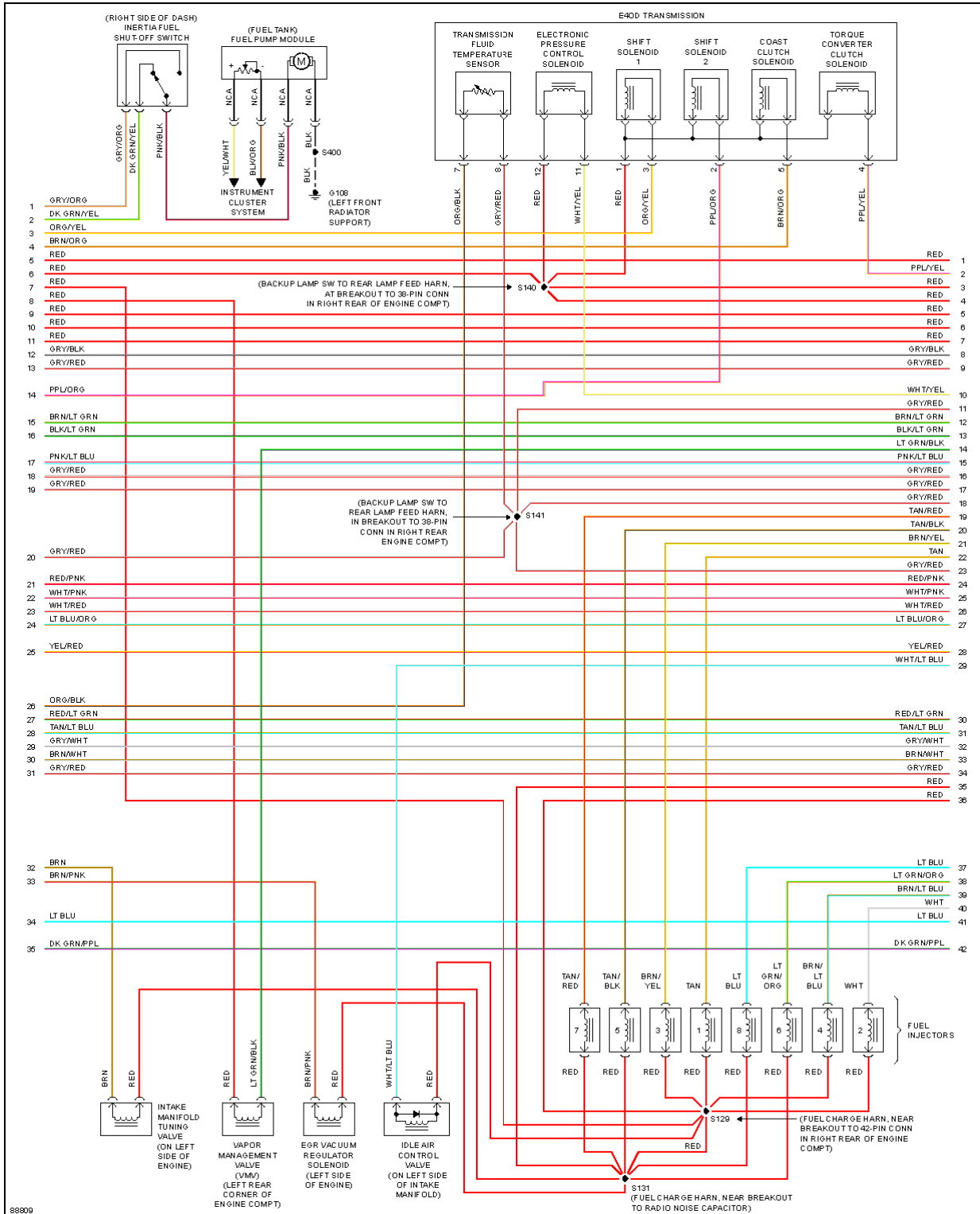

**1997 Ford Pickup F150**

1997 System Wiring Diagrams Ford - Pickup F150

**Fig. 31: 5.4L, Engine Performance Circuits (3 of 4)**

# 1997 Ford Pickup F150

## 1997 System Wiring Diagrams Ford - Pickup F150

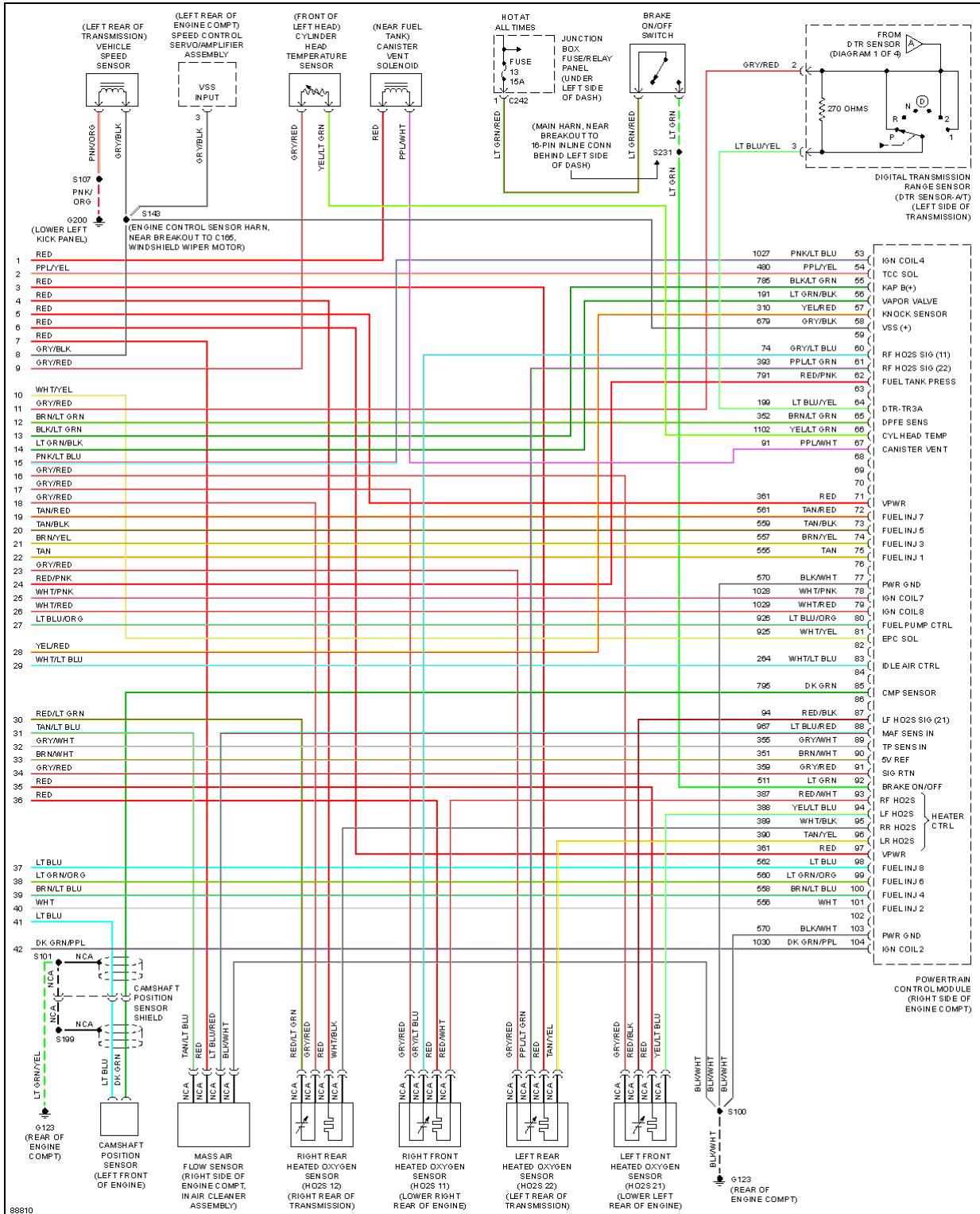



**1997 Ford Pickup F150**

1997 System Wiring Diagrams Ford - Pickup F150

**Fig. 32: 5.4L, Engine Performance Circuits (4 of 4)**

**EXTERIOR LIGHTS**

# 1997 Ford Pickup F150

## 1997 System Wiring Diagrams Ford - Pickup F150

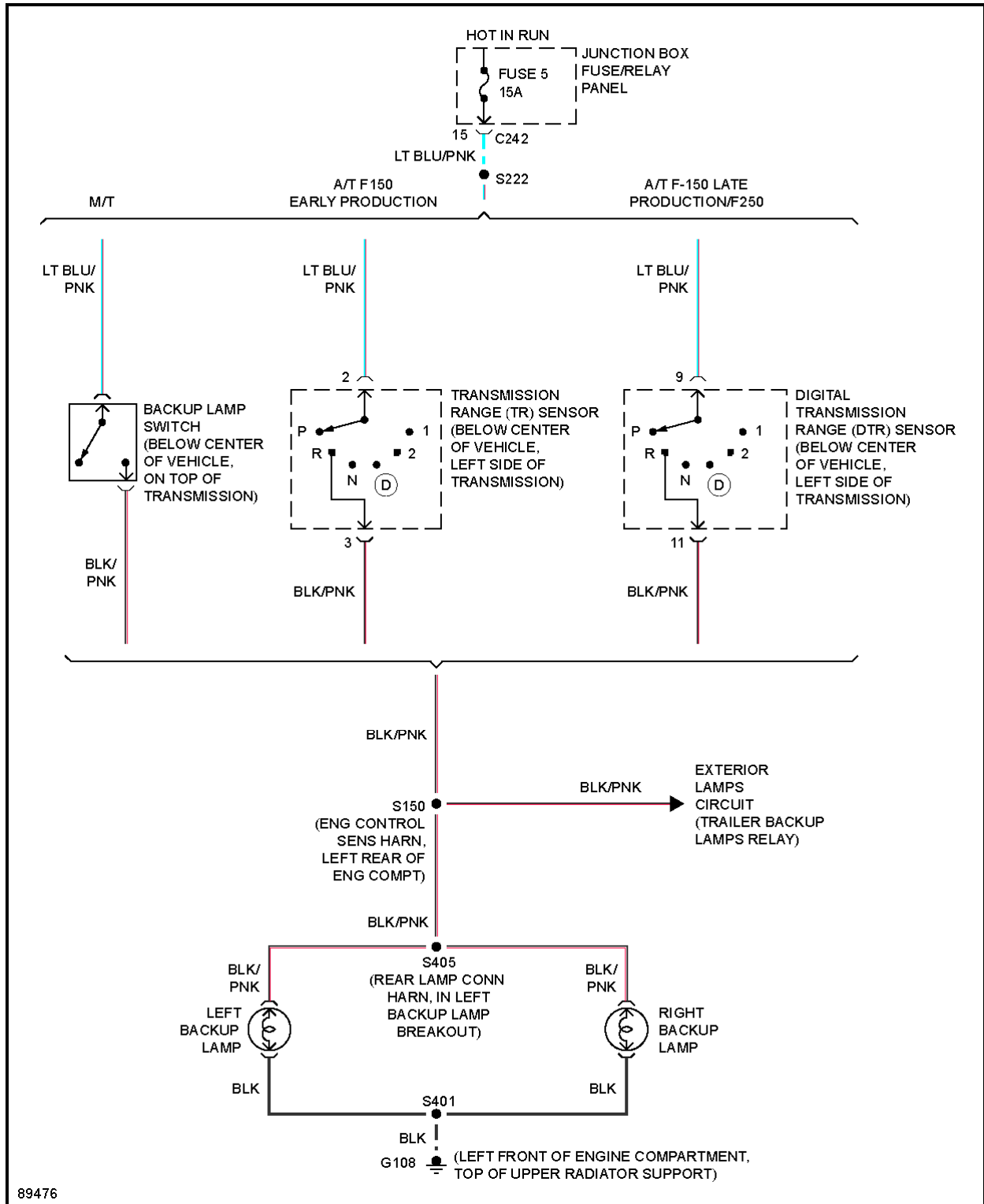

## 1997 Ford Pickup F150

1997 System Wiring Diagrams Ford - Pickup F150

### **Fig. 33: Back-up Lamps Circuit**

# 1997 Ford Pickup F150

## 1997 System Wiring Diagrams Ford - Pickup F150

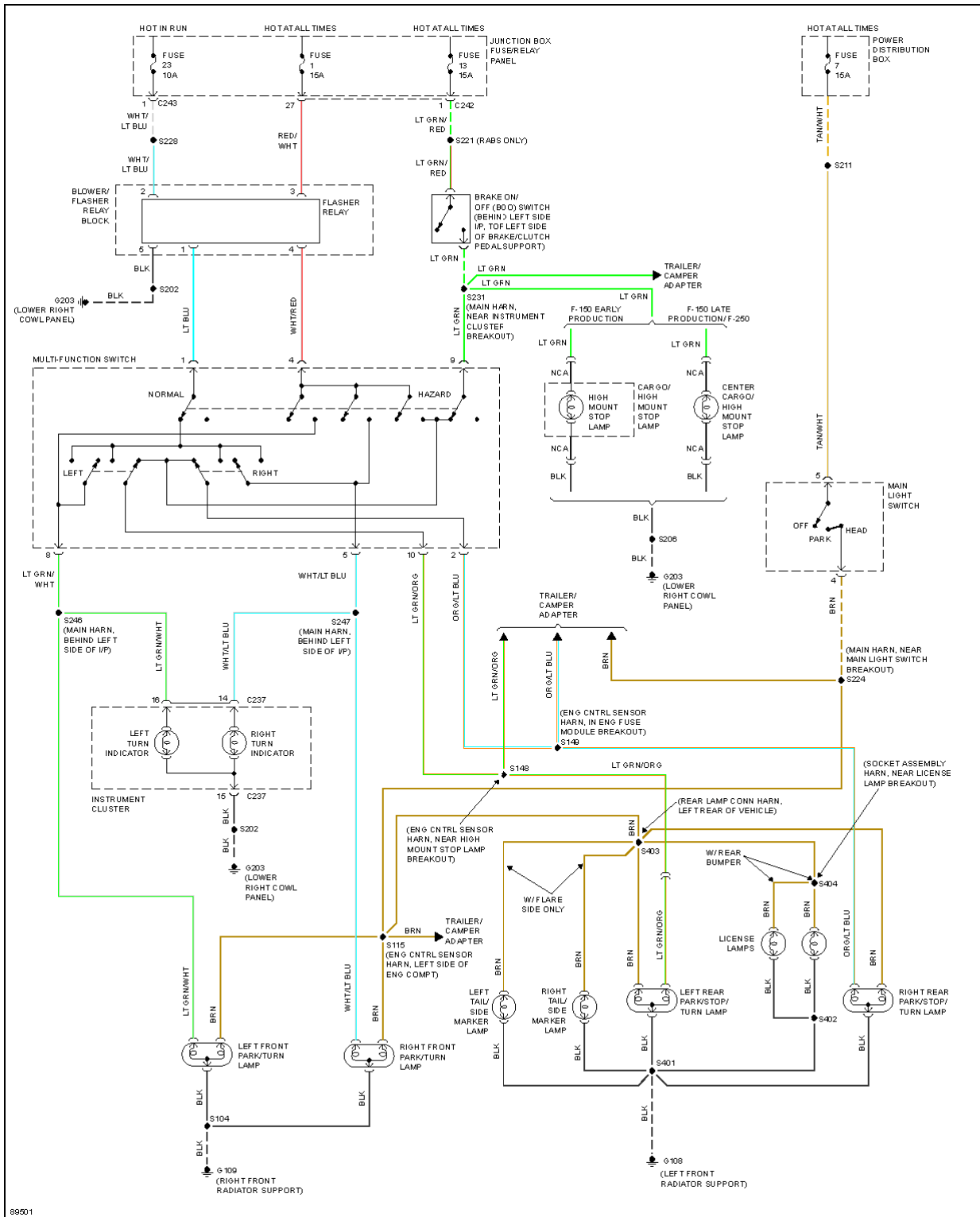

## 1997 Ford Pickup F150

1997 System Wiring Diagrams Ford - Pickup F150

**Fig. 34: Exterior Lamps Circuit**

# 1997 Ford Pickup F150

## 1997 System Wiring Diagrams Ford - Pickup F150

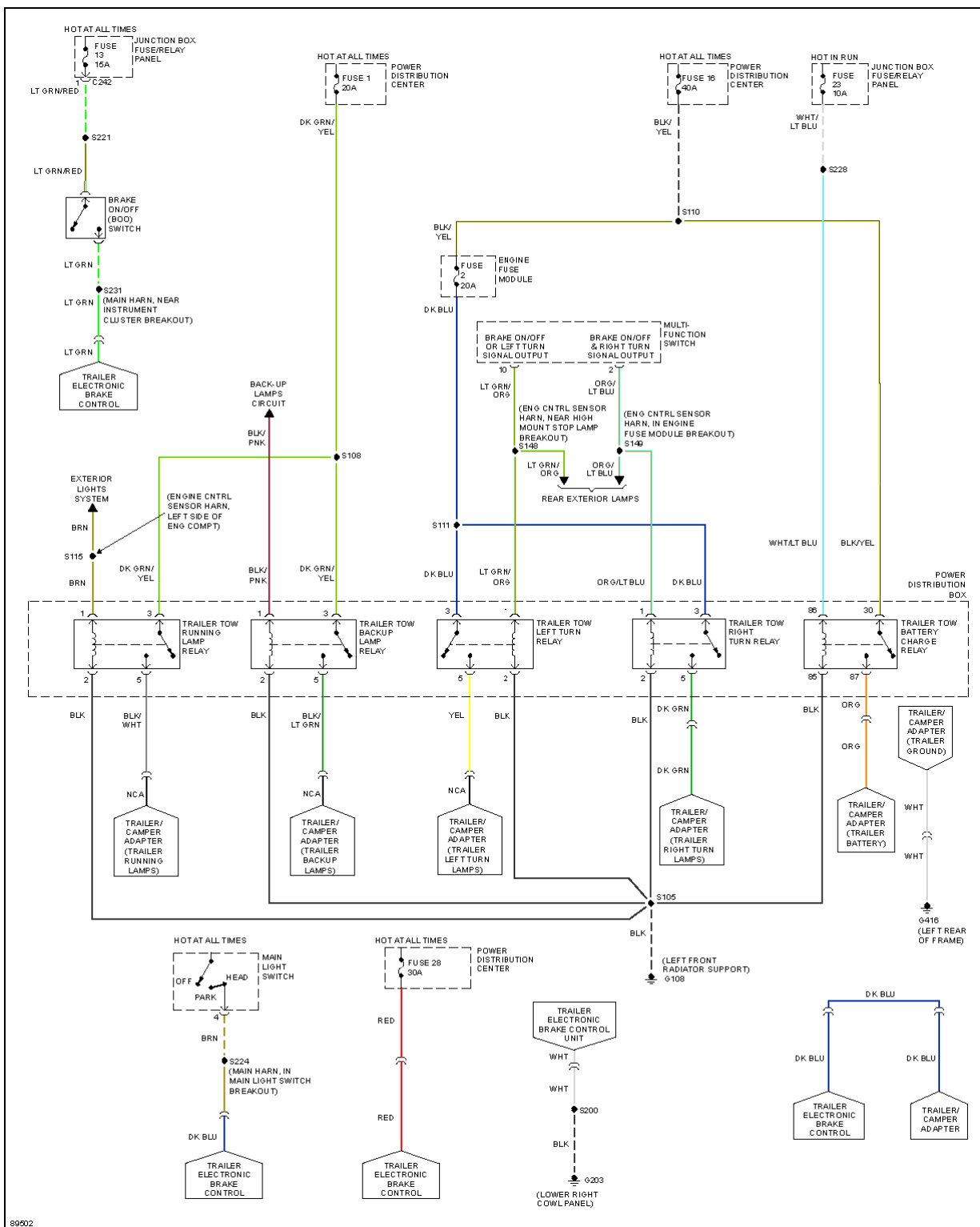
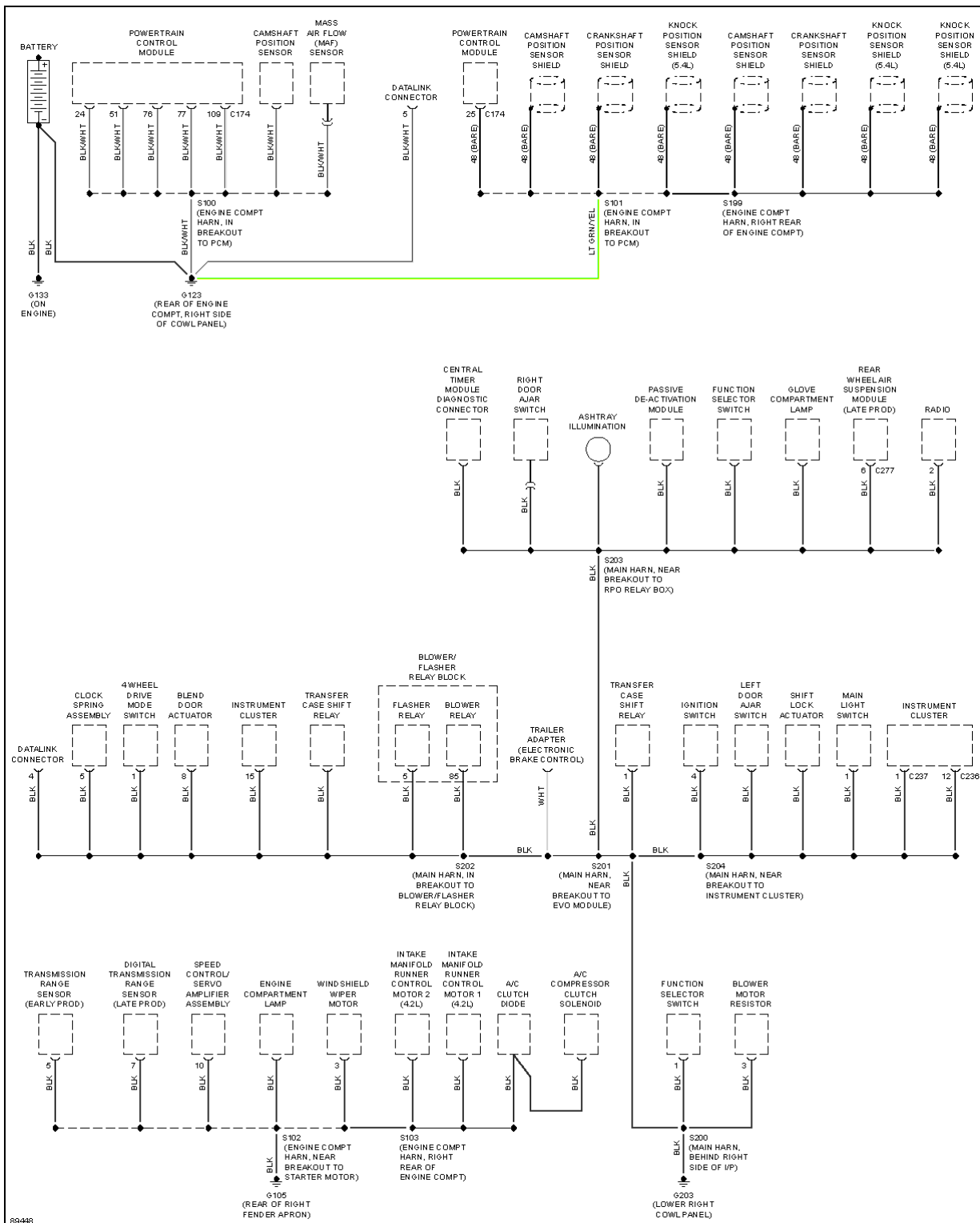

**Fig. 35: Trailer/Camper Adapter Circuit**

**GROUND DISTRIBUTION**

# 1997 Ford Pickup F150

## 1997 System Wiring Diagrams Ford - Pickup F150





**1997 Ford Pickup F150**

1997 System Wiring Diagrams Ford - Pickup F150

**Fig. 36: Ground Distribution Circuit (1 of 3)**

# 1997 Ford Pickup F150

## 1997 System Wiring Diagrams Ford - Pickup F150

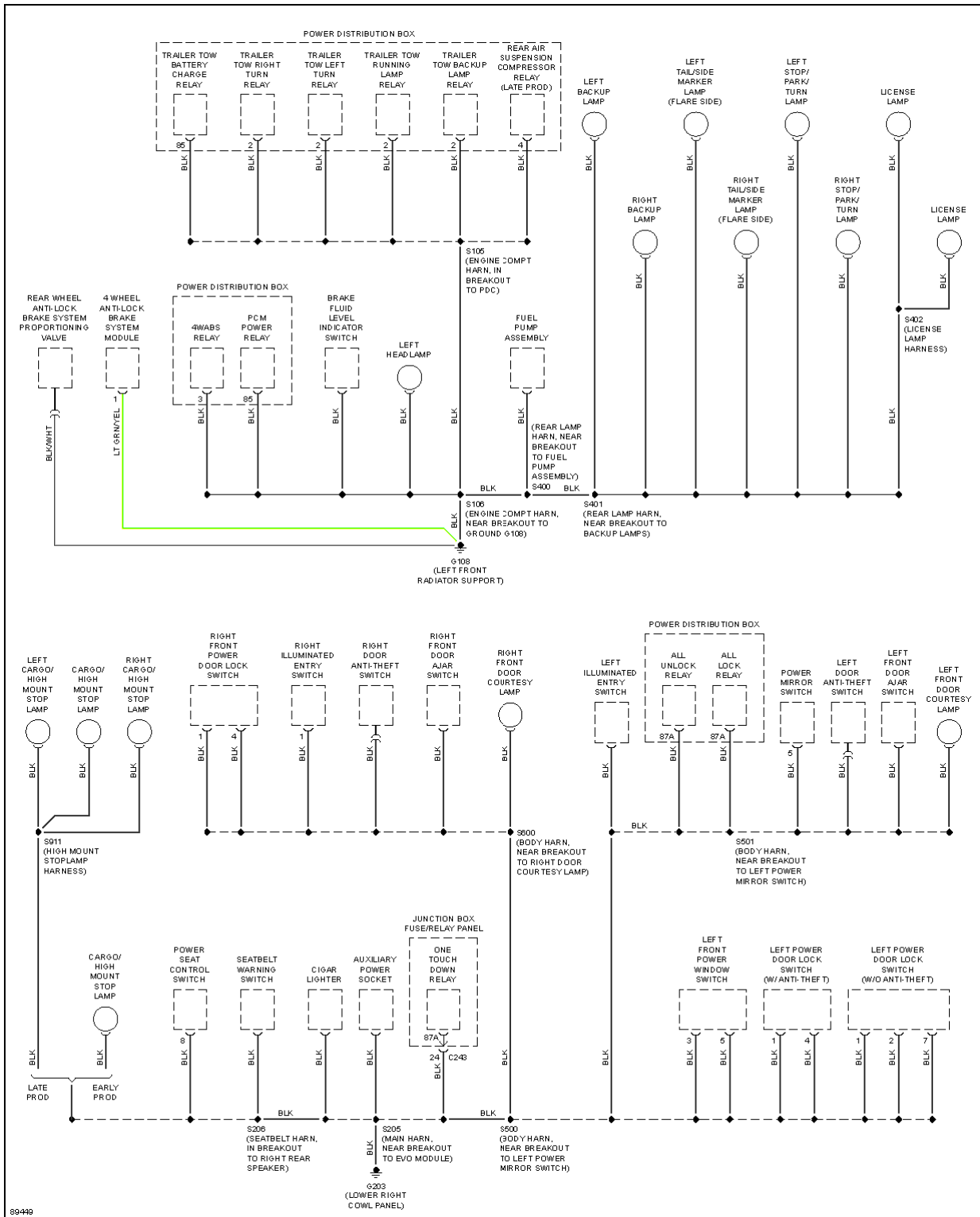

**1997 Ford Pickup F150**

1997 System Wiring Diagrams Ford - Pickup F150

**Fig. 37: Ground Distribution Circuit (2 of 3)**

# 1997 Ford Pickup F150

## 1997 System Wiring Diagrams Ford - Pickup F150

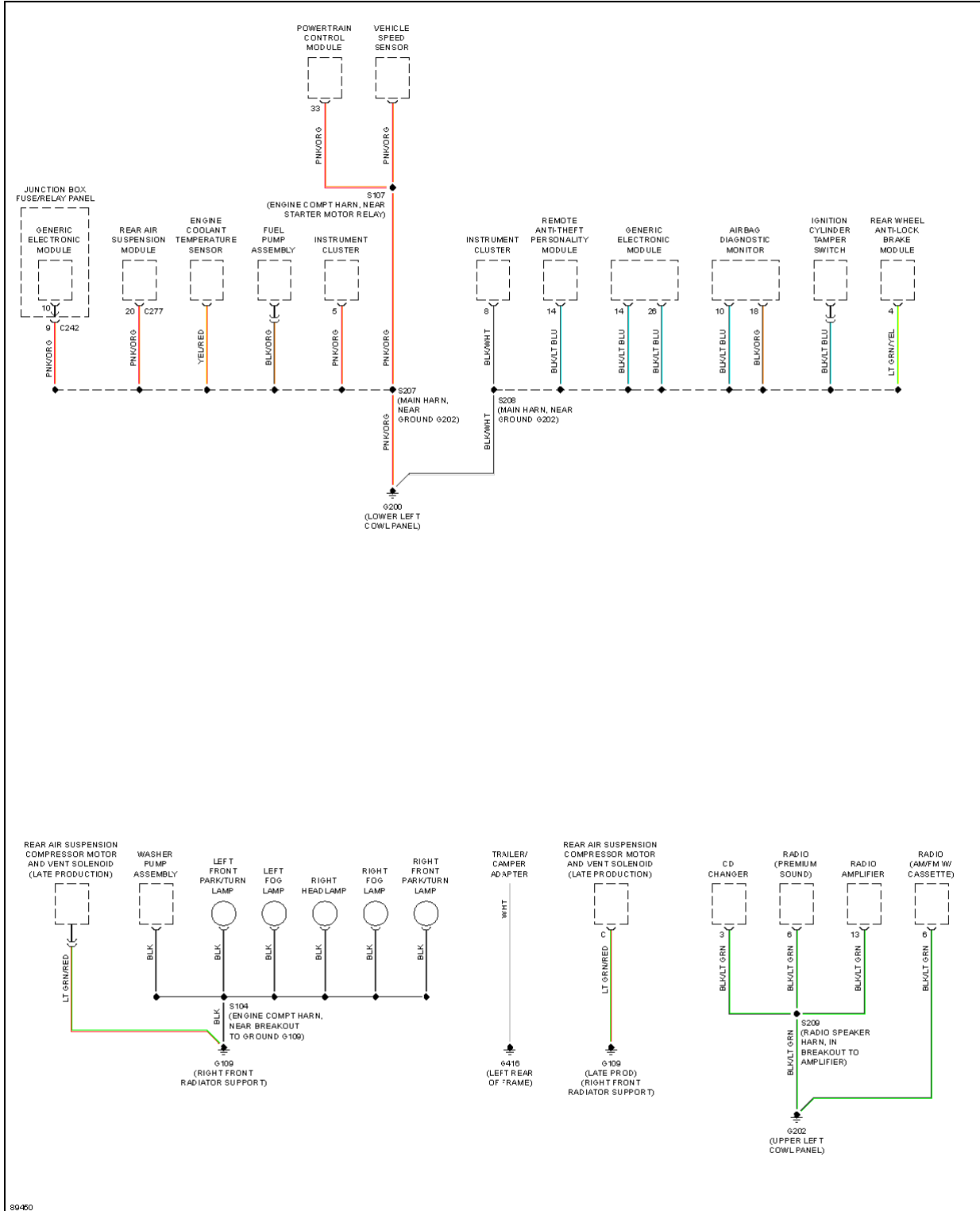

**1997 Ford Pickup F150**

1997 System Wiring Diagrams Ford - Pickup F150

**Fig. 38: Ground Distribution Circuit (3 of 3)**

**HEADLIGHTS**

# 1997 Ford Pickup F150

## 1997 System Wiring Diagrams Ford - Pickup F150

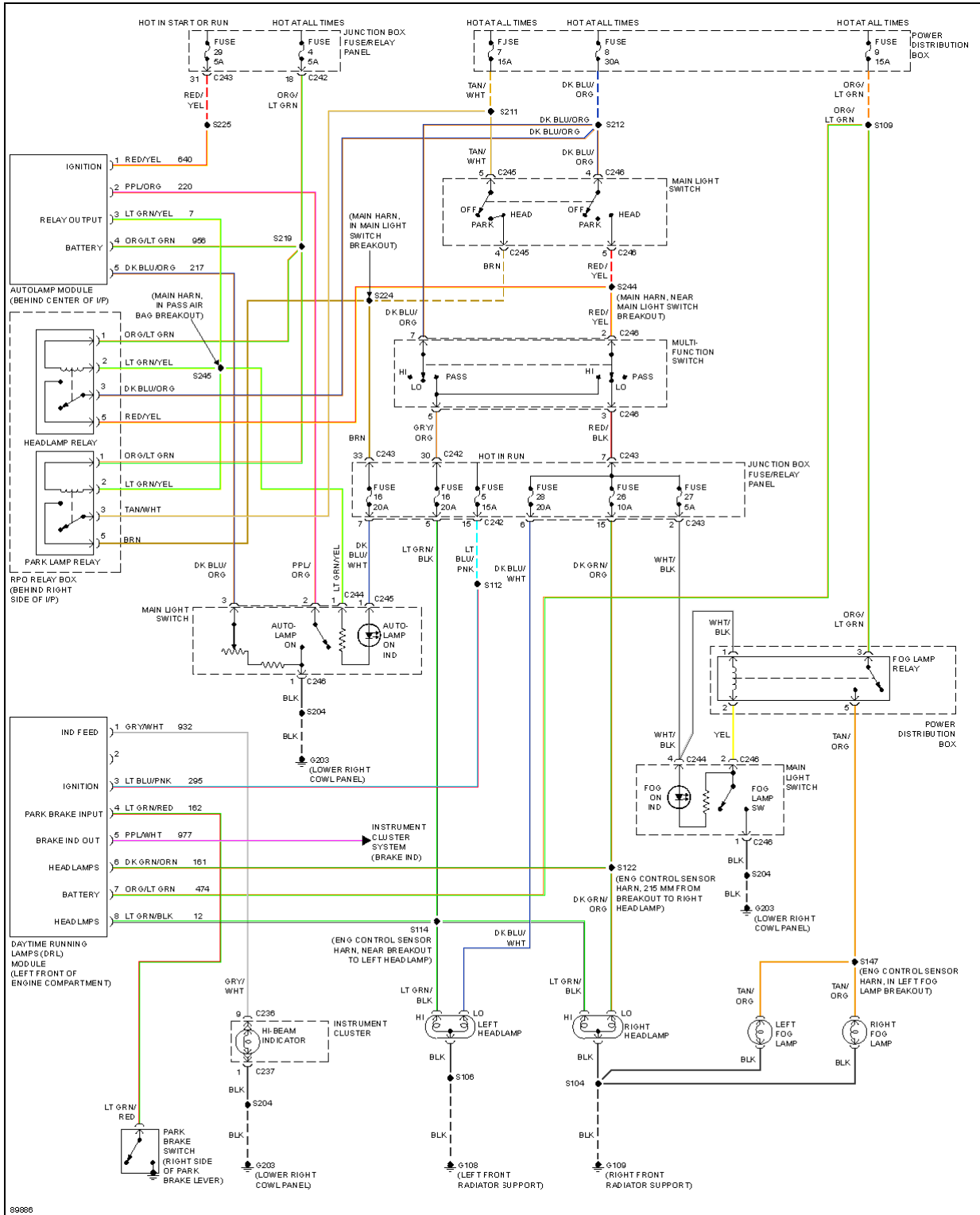

**1997 Ford Pickup F150**

1997 System Wiring Diagrams Ford - Pickup F150

**Fig. 39: Autolamps Circuit, W/ DRL**

# 1997 Ford Pickup F150

## 1997 System Wiring Diagrams Ford - Pickup F150

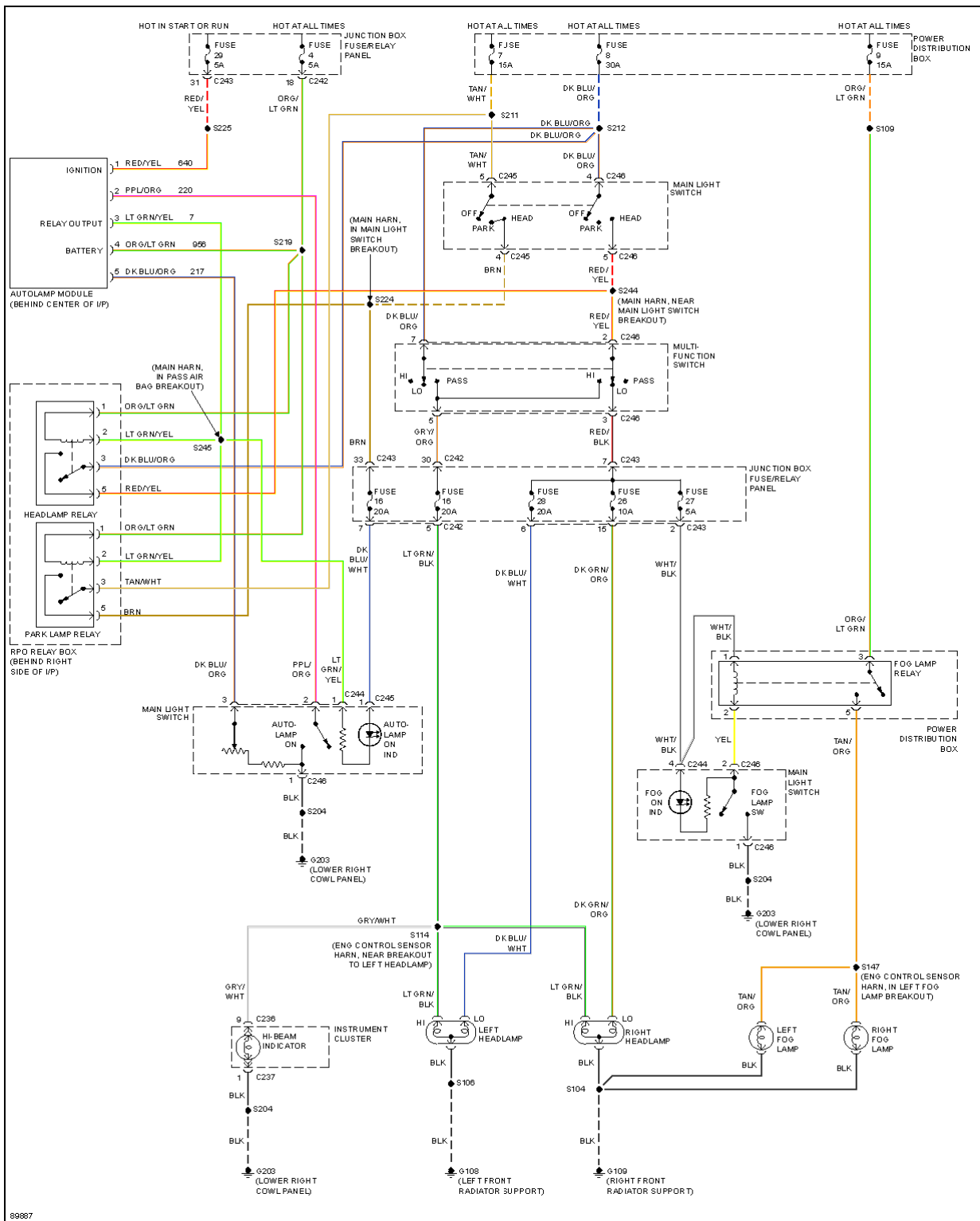



**1997 Ford Pickup F150**

1997 System Wiring Diagrams Ford - Pickup F150

**Fig. 40: Autolamps Circuit, W/O DRL**

# 1997 Ford Pickup F150

## 1997 System Wiring Diagrams Ford - Pickup F150

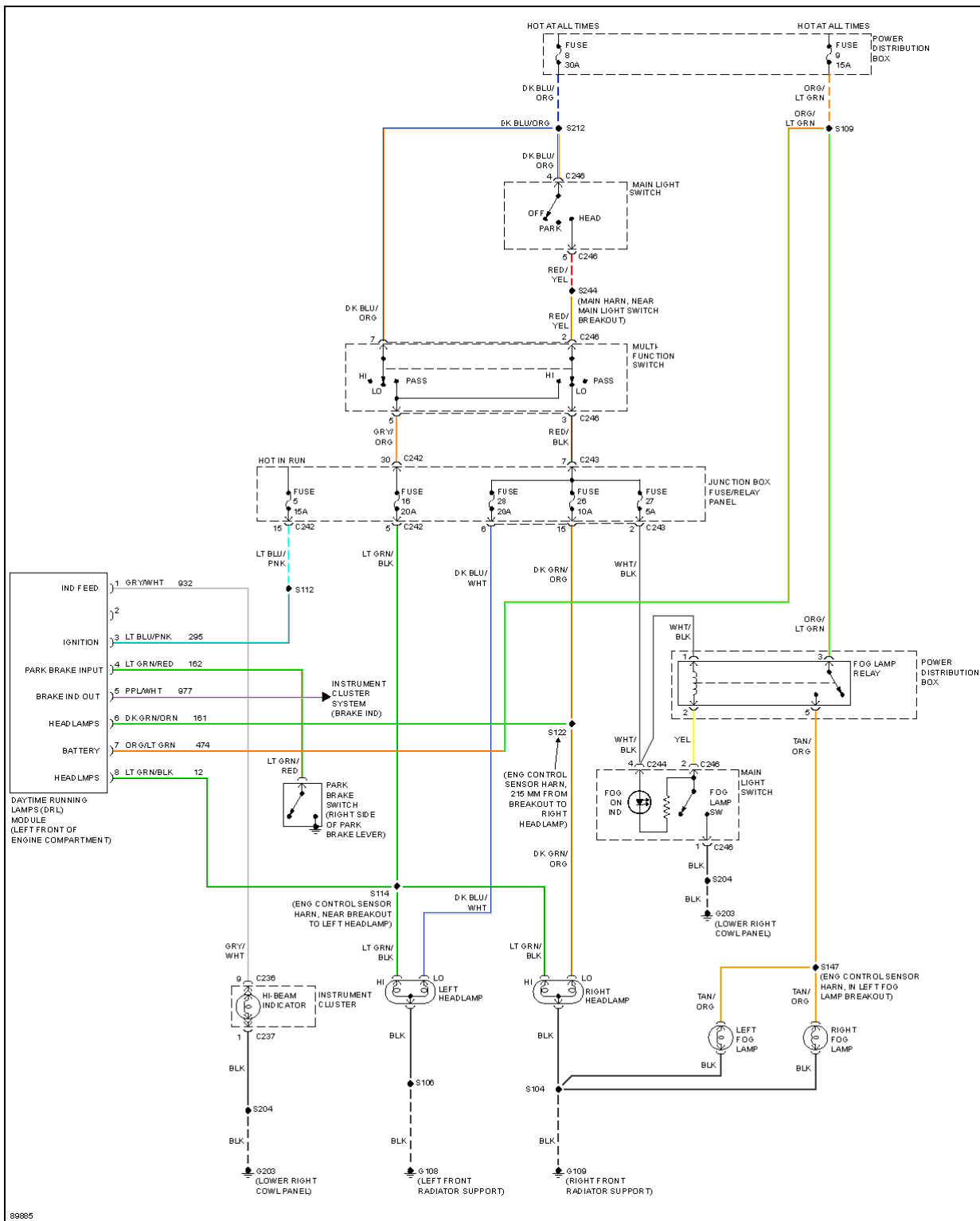

**1997 Ford Pickup F150**

1997 System Wiring Diagrams Ford - Pickup F150

**Fig. 41: Headlamps Circuit, W/ DRL**

# 1997 Ford Pickup F150

## 1997 System Wiring Diagrams Ford - Pickup F150

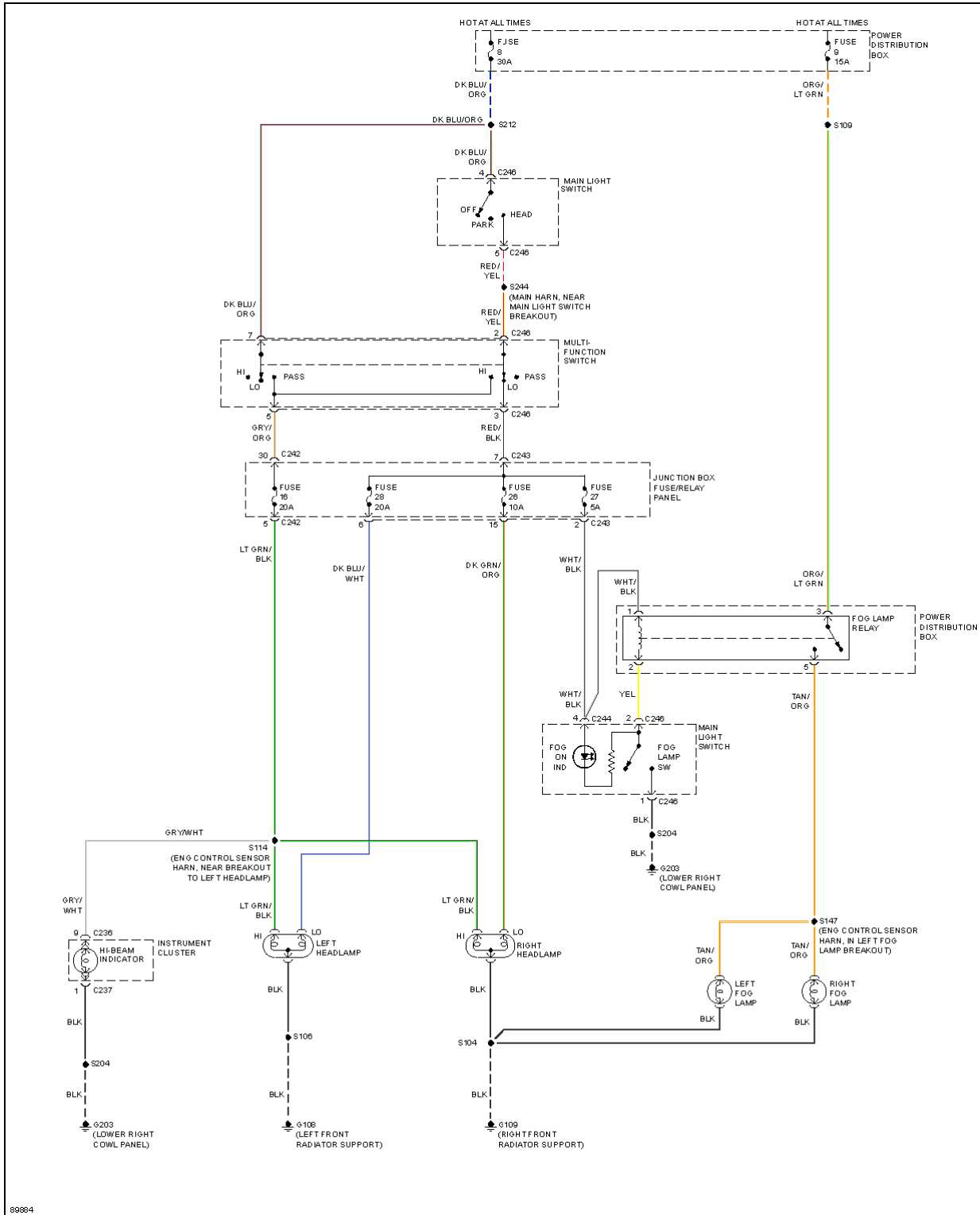

**1997 Ford Pickup F150**

1997 System Wiring Diagrams Ford - Pickup F150

**Fig. 42: Headlamps Circuit, W/O DRL**

**HORN**

# 1997 Ford Pickup F150

## 1997 System Wiring Diagrams Ford - Pickup F150

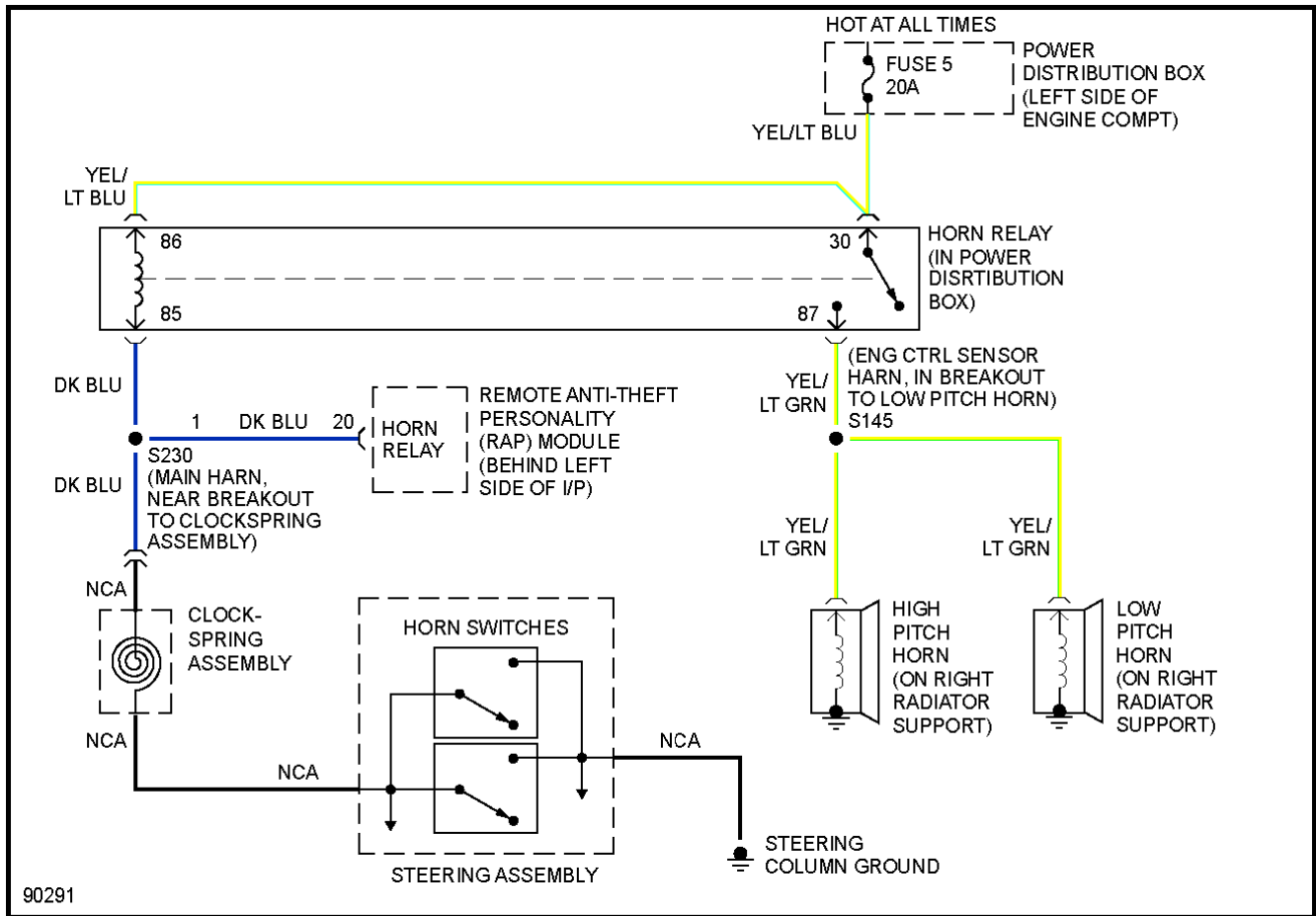

**1997 Ford Pickup F150**

1997 System Wiring Diagrams Ford - Pickup F150

**Fig. 43: Horn Circuit**

**INSTRUMENT CLUSTER**

# 1997 Ford Pickup F150

## 1997 System Wiring Diagrams Ford - Pickup F150

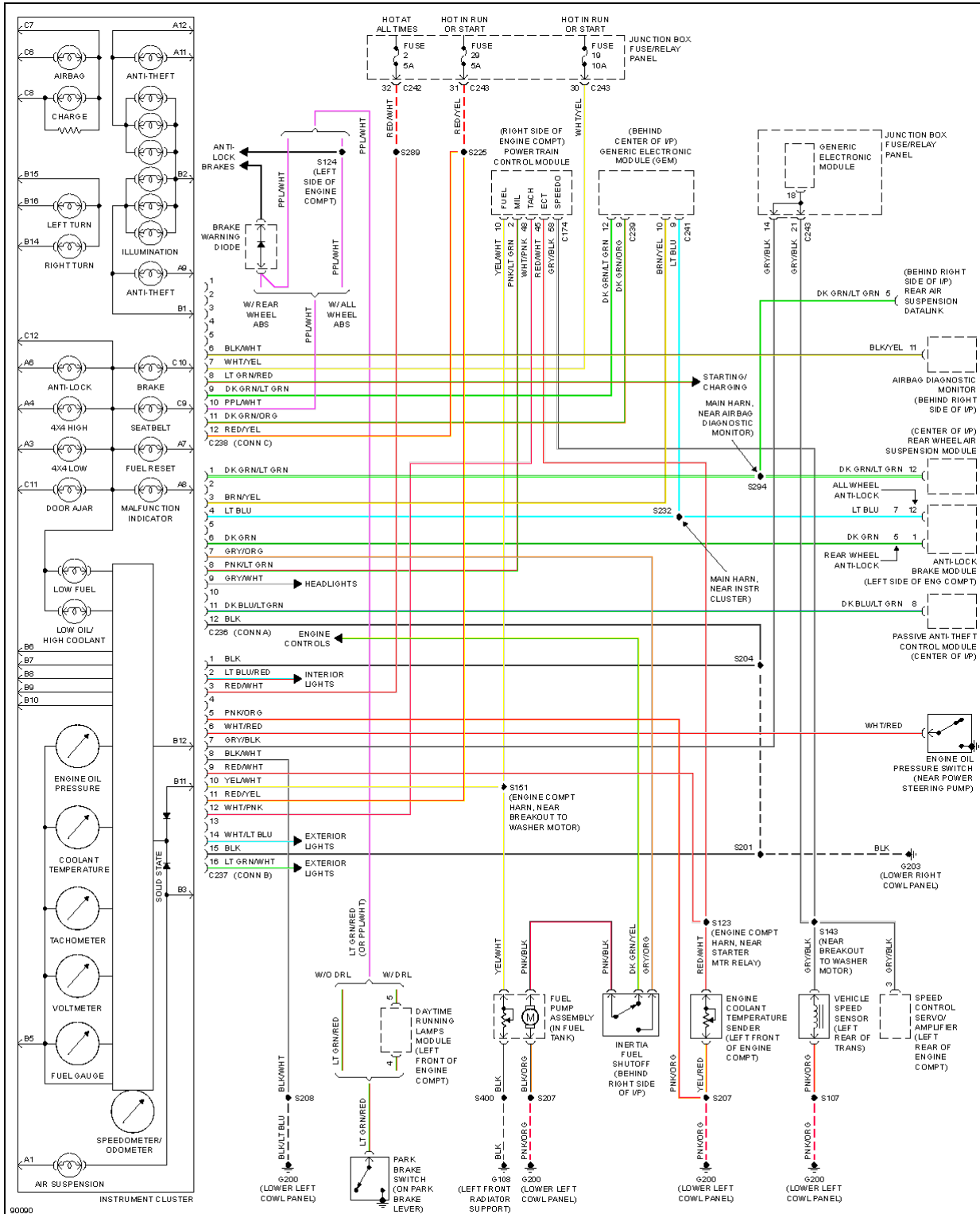



**1997 Ford Pickup F150**

1997 System Wiring Diagrams Ford - Pickup F150

**Fig. 44: Instrument Cluster Circuit**

**INTERIOR LIGHTS**

# 1997 Ford Pickup F150

## 1997 System Wiring Diagrams Ford - Pickup F150

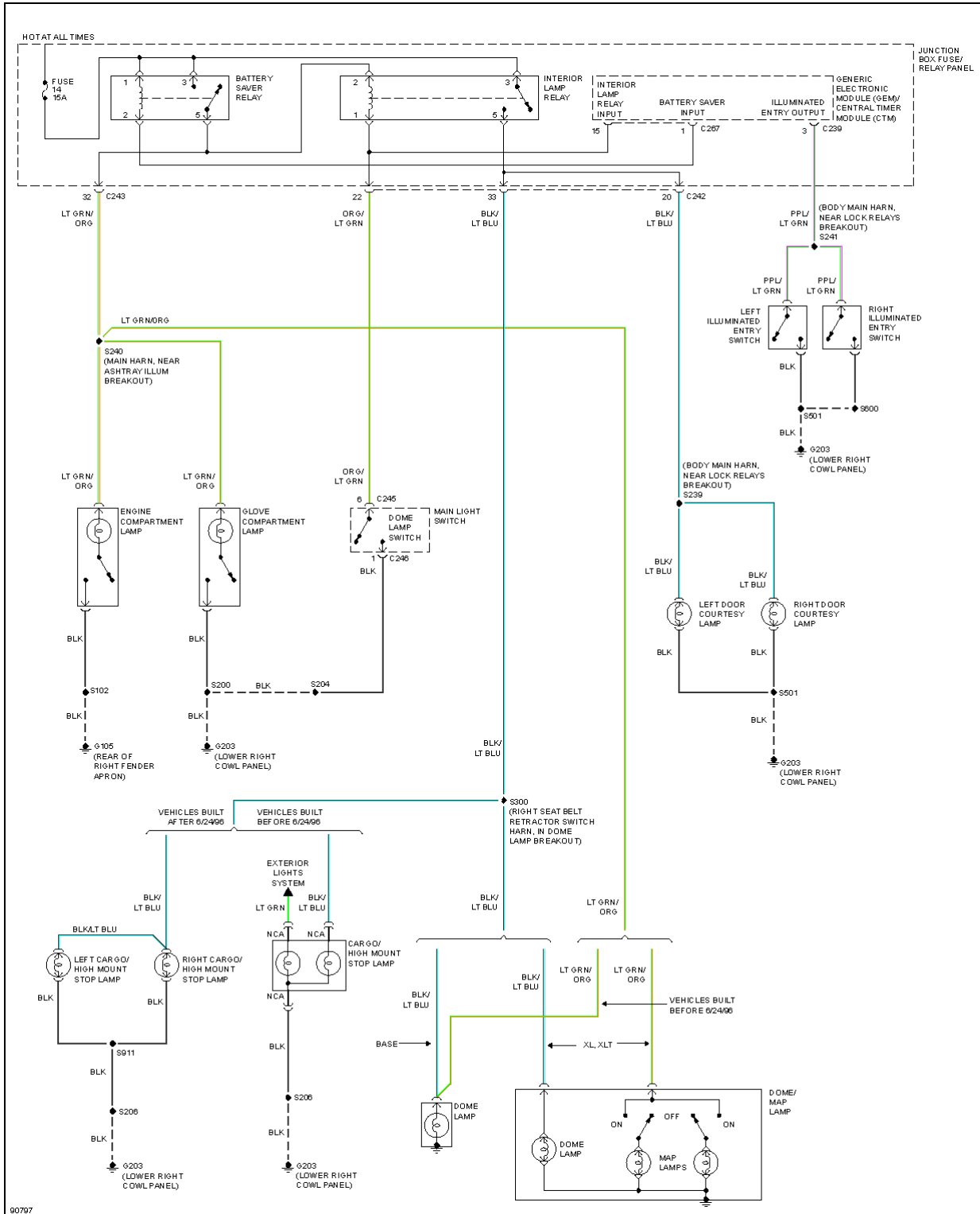

## 1997 Ford Pickup F150

1997 System Wiring Diagrams Ford - Pickup F150

### **Fig. 45: Courtesy Lamp Circuit**

# 1997 Ford Pickup F150

## 1997 System Wiring Diagrams Ford - Pickup F150

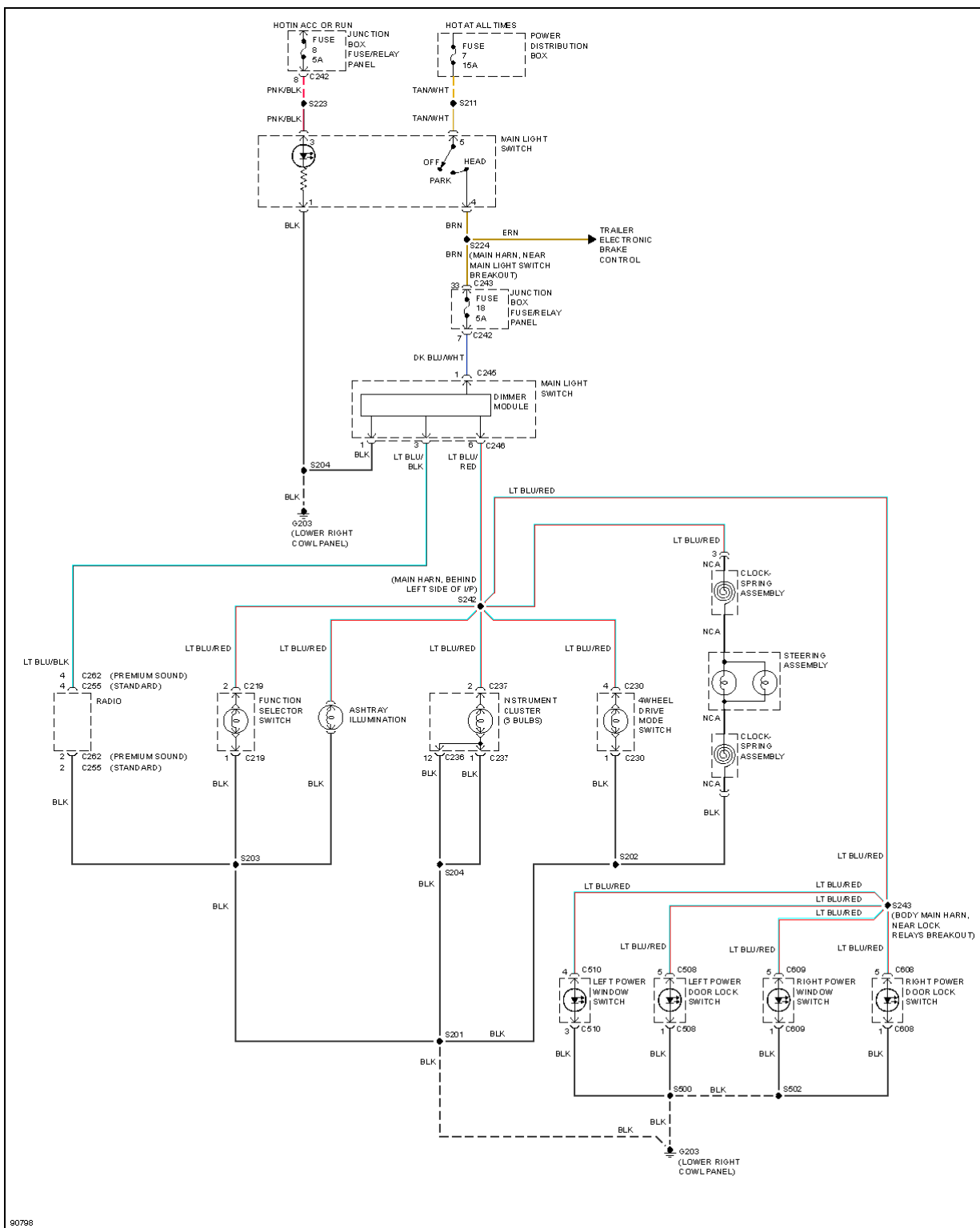

**1997 Ford Pickup F150**

1997 System Wiring Diagrams Ford - Pickup F150

**Fig. 46: Instrument Illumination Circuit**

**POWER DISTRIBUTION**

# 1997 Ford Pickup F150

## 1997 System Wiring Diagrams Ford - Pickup F150

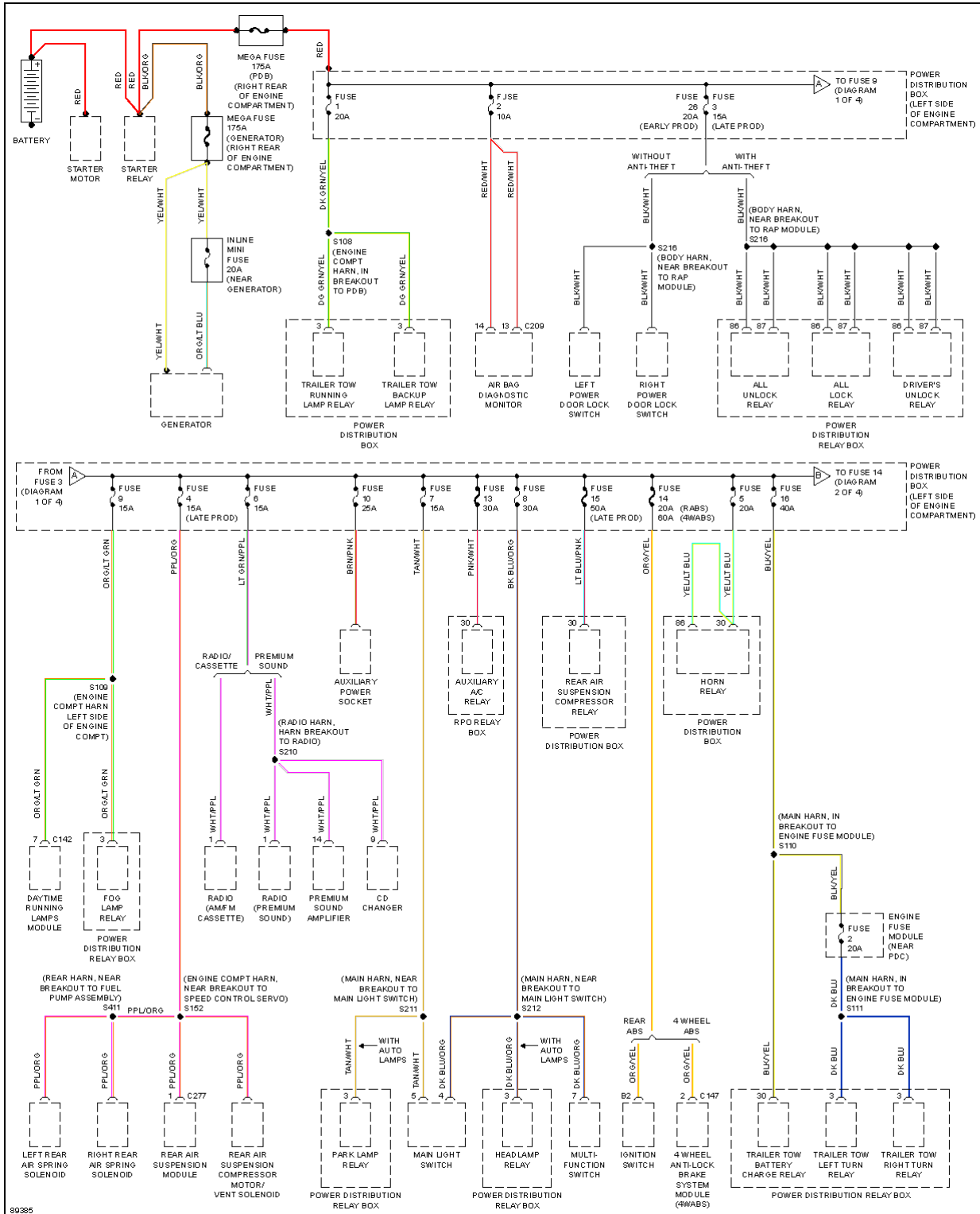

## 1997 Ford Pickup F150

1997 System Wiring Diagrams Ford - Pickup F150

**Fig. 47: Power Distribution Circuit (1 of 4)**

# 1997 Ford Pickup F150

## 1997 System Wiring Diagrams Ford - Pickup F150

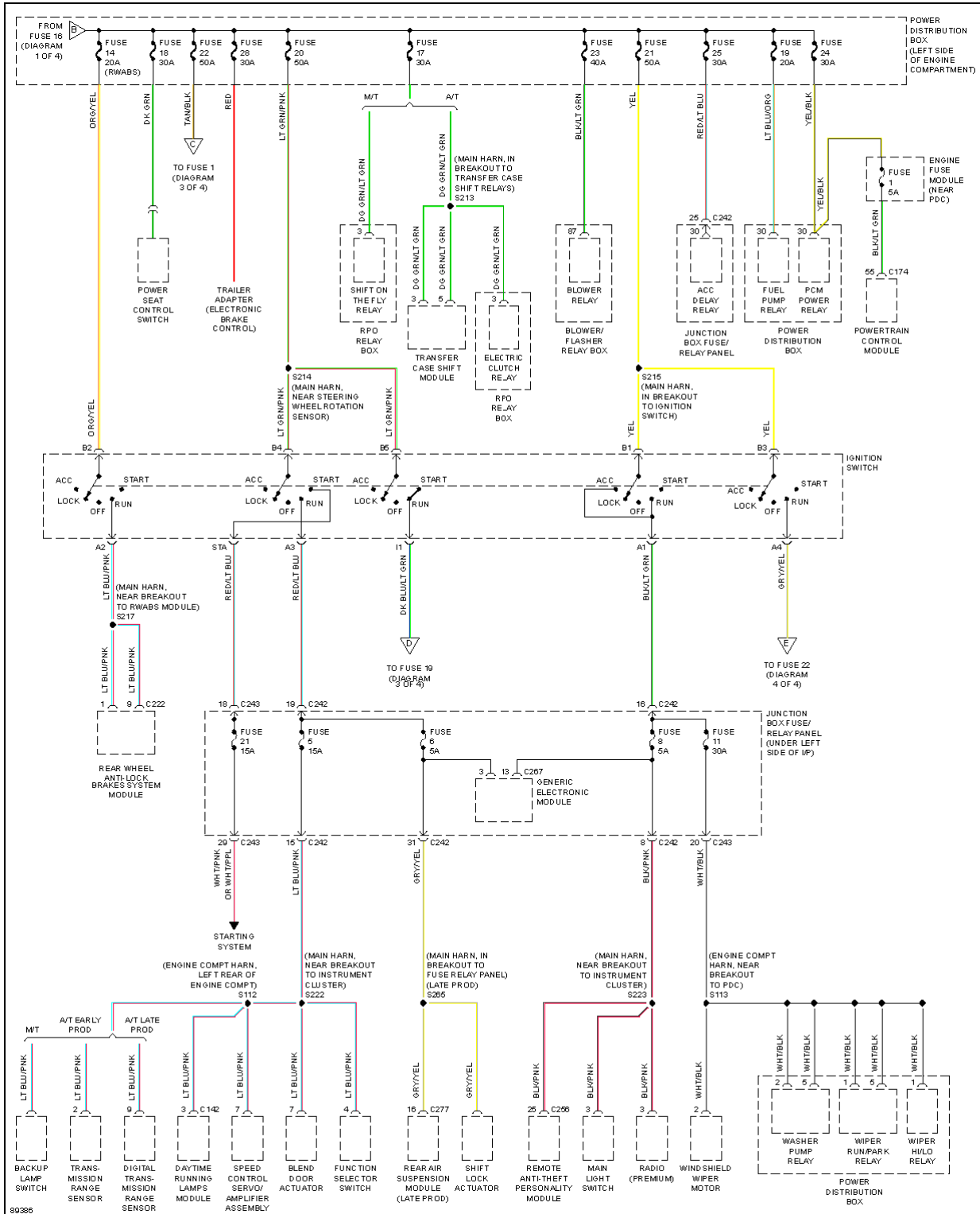



**1997 Ford Pickup F150**

1997 System Wiring Diagrams Ford - Pickup F150

**Fig. 48: Power Distribution Circuit (2 of 4)**

# 1997 Ford Pickup F150

## 1997 System Wiring Diagrams Ford - Pickup F150

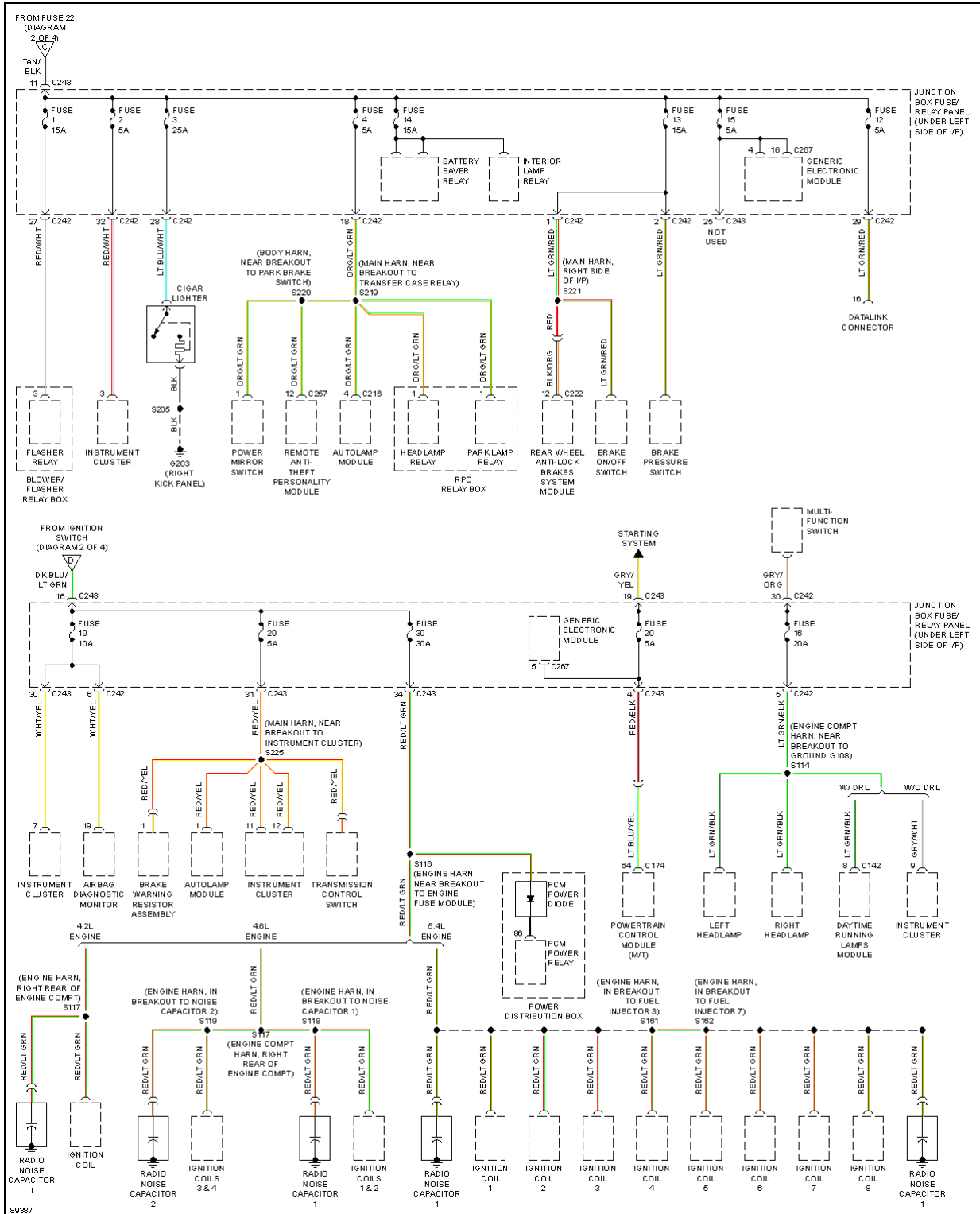

**1997 Ford Pickup F150**

1997 System Wiring Diagrams Ford - Pickup F150

**Fig. 49: Power Distribution Circuit (3 of 4)**

# 1997 Ford Pickup F150

## 1997 System Wiring Diagrams Ford - Pickup F150

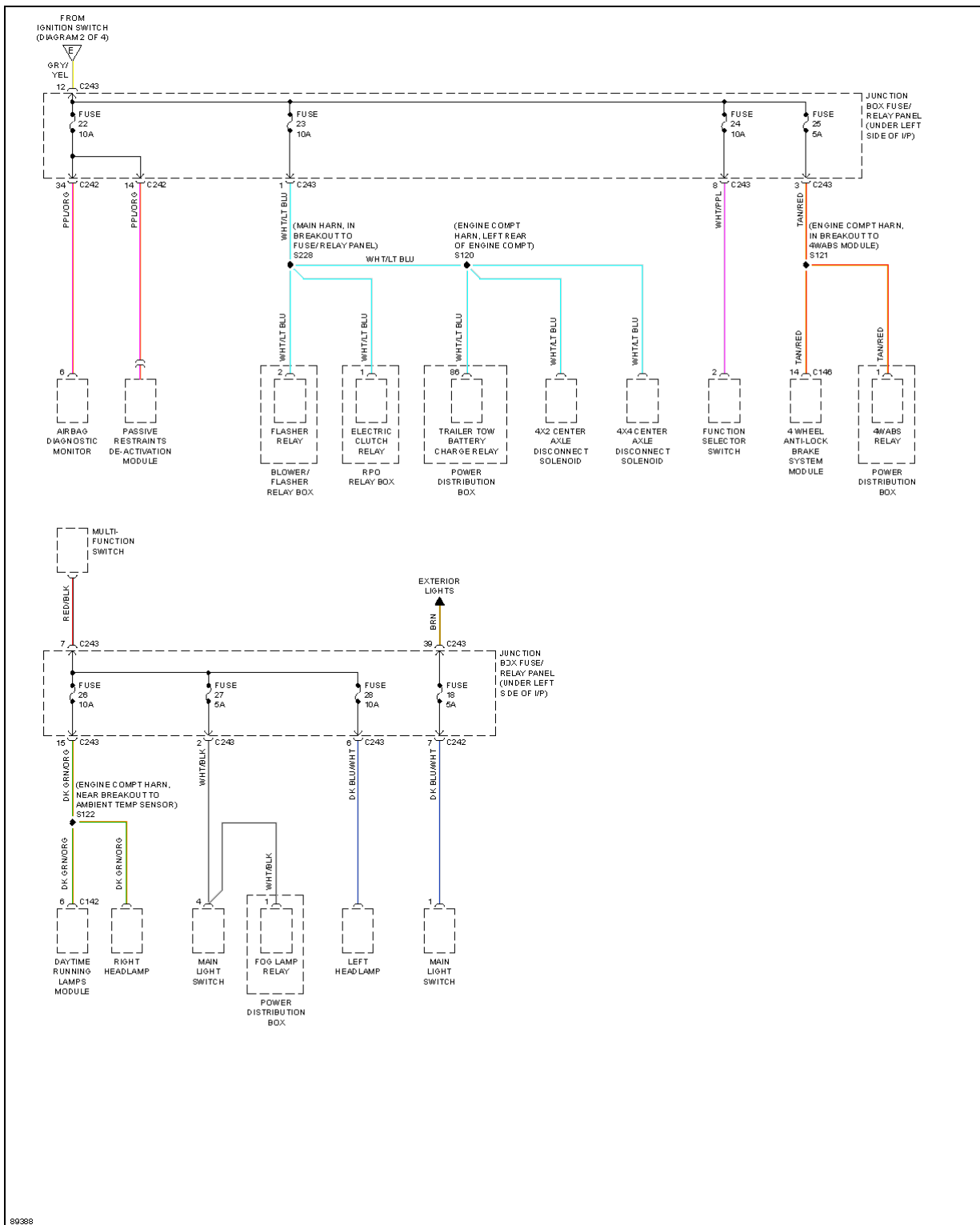
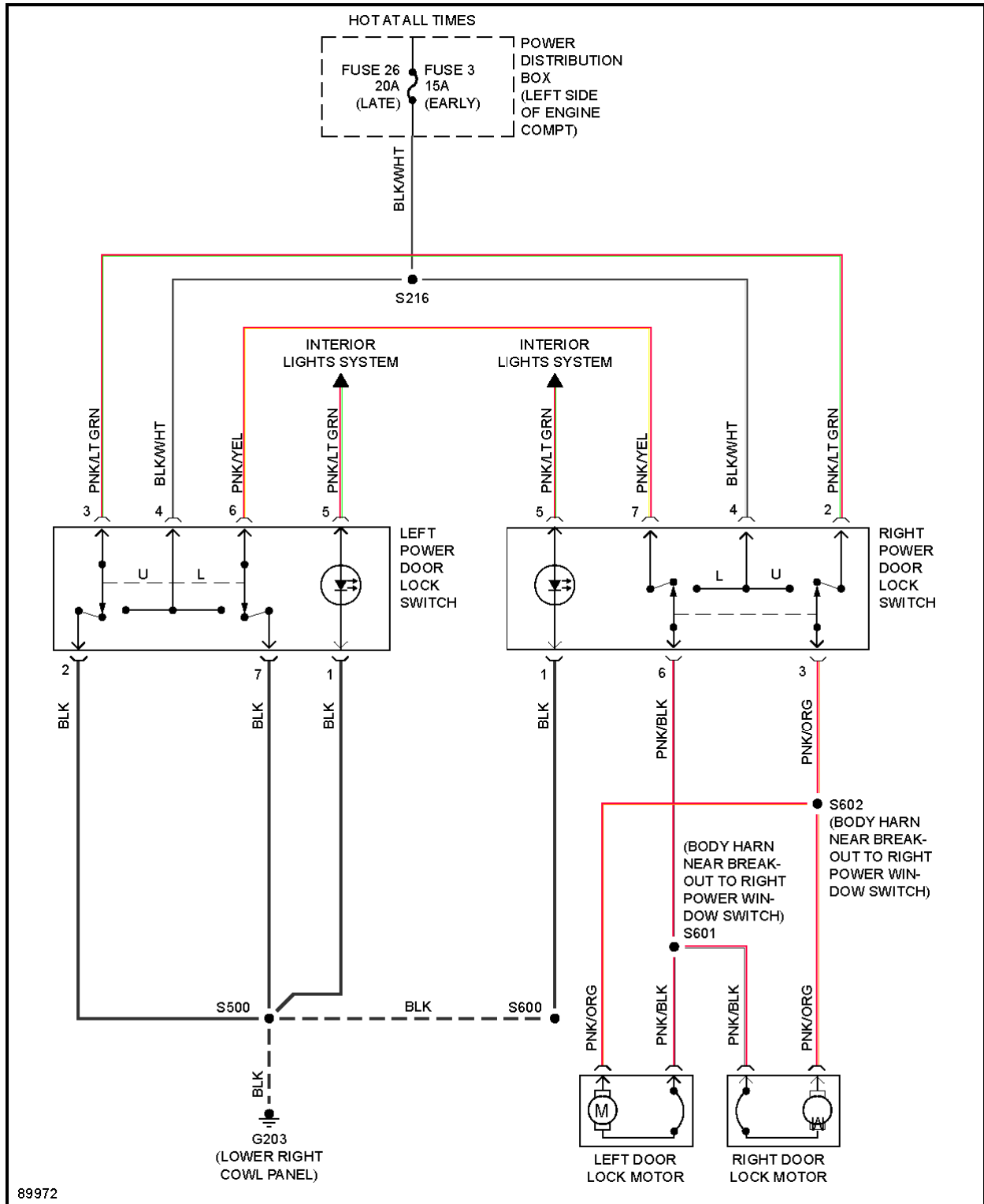

**Fig. 50: Power Distribution Circuit (4 of 4)**

## **POWER DOOR LOCKS**

# 1997 Ford Pickup F150

## 1997 System Wiring Diagrams Ford - Pickup F150



**1997 Ford Pickup F150**

1997 System Wiring Diagrams Ford - Pickup F150

**Fig. 51: Door Lock Circuit**

# 1997 Ford Pickup F150

## 1997 System Wiring Diagrams Ford - Pickup F150

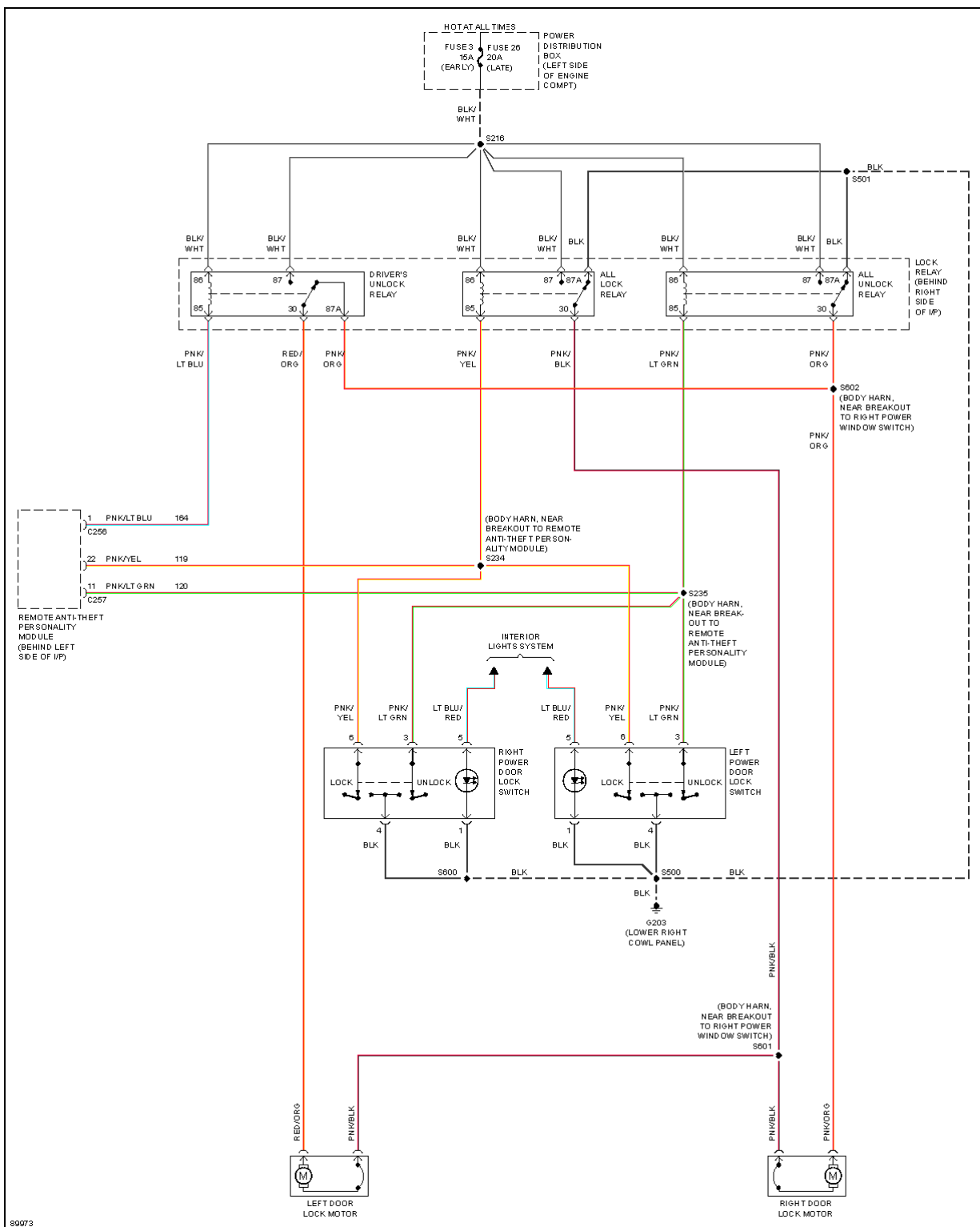



**1997 Ford Pickup F150**

1997 System Wiring Diagrams Ford - Pickup F150

**Fig. 52: Keyless Entry Circuit**

**POWER MIRRORS**

# 1997 Ford Pickup F150

## 1997 System Wiring Diagrams Ford - Pickup F150

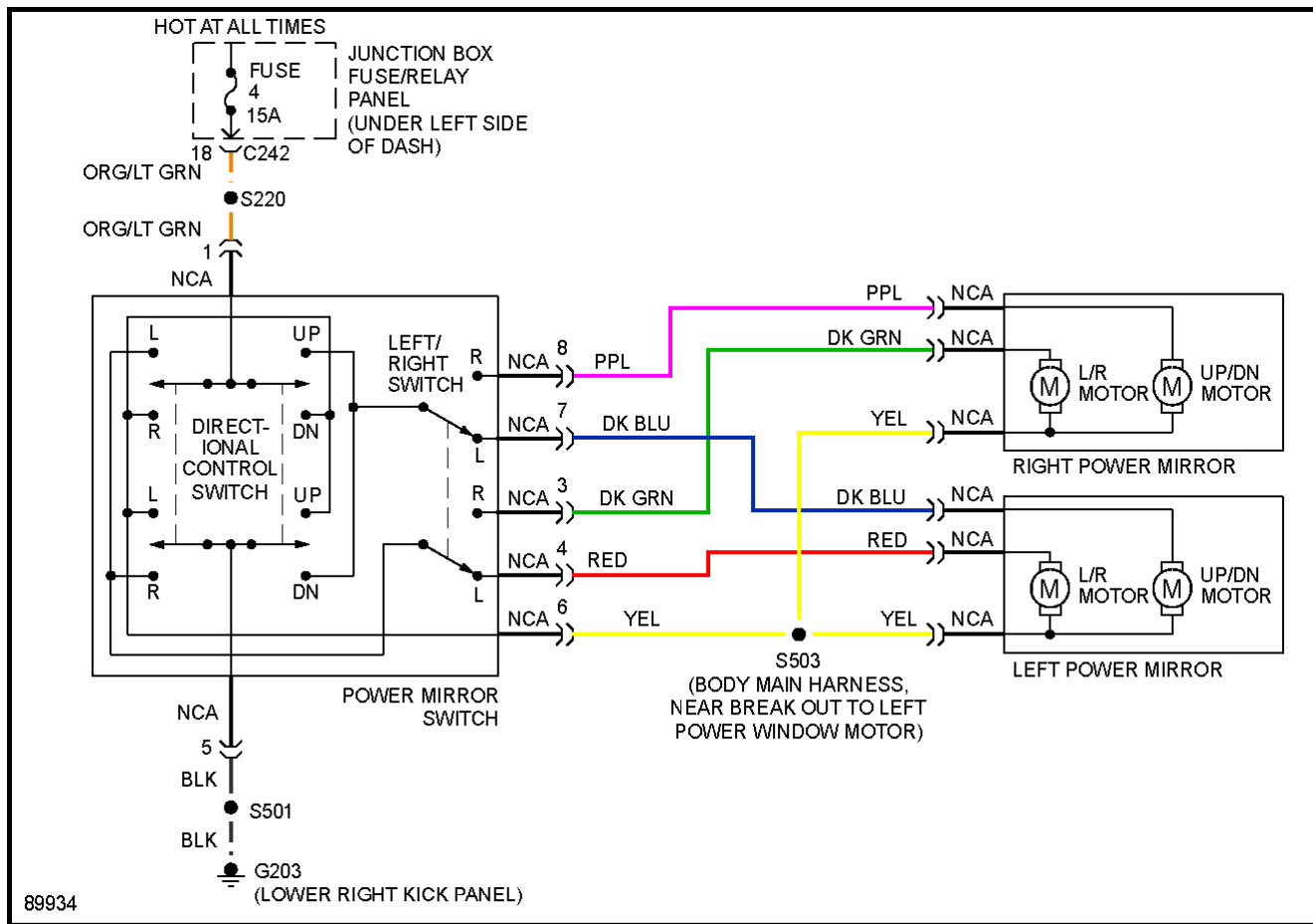

**1997 Ford Pickup F150**

1997 System Wiring Diagrams Ford - Pickup F150

**Fig. 53: Power Mirror Circuit**

**POWER SEATS**

# 1997 Ford Pickup F150

## 1997 System Wiring Diagrams Ford - Pickup F150

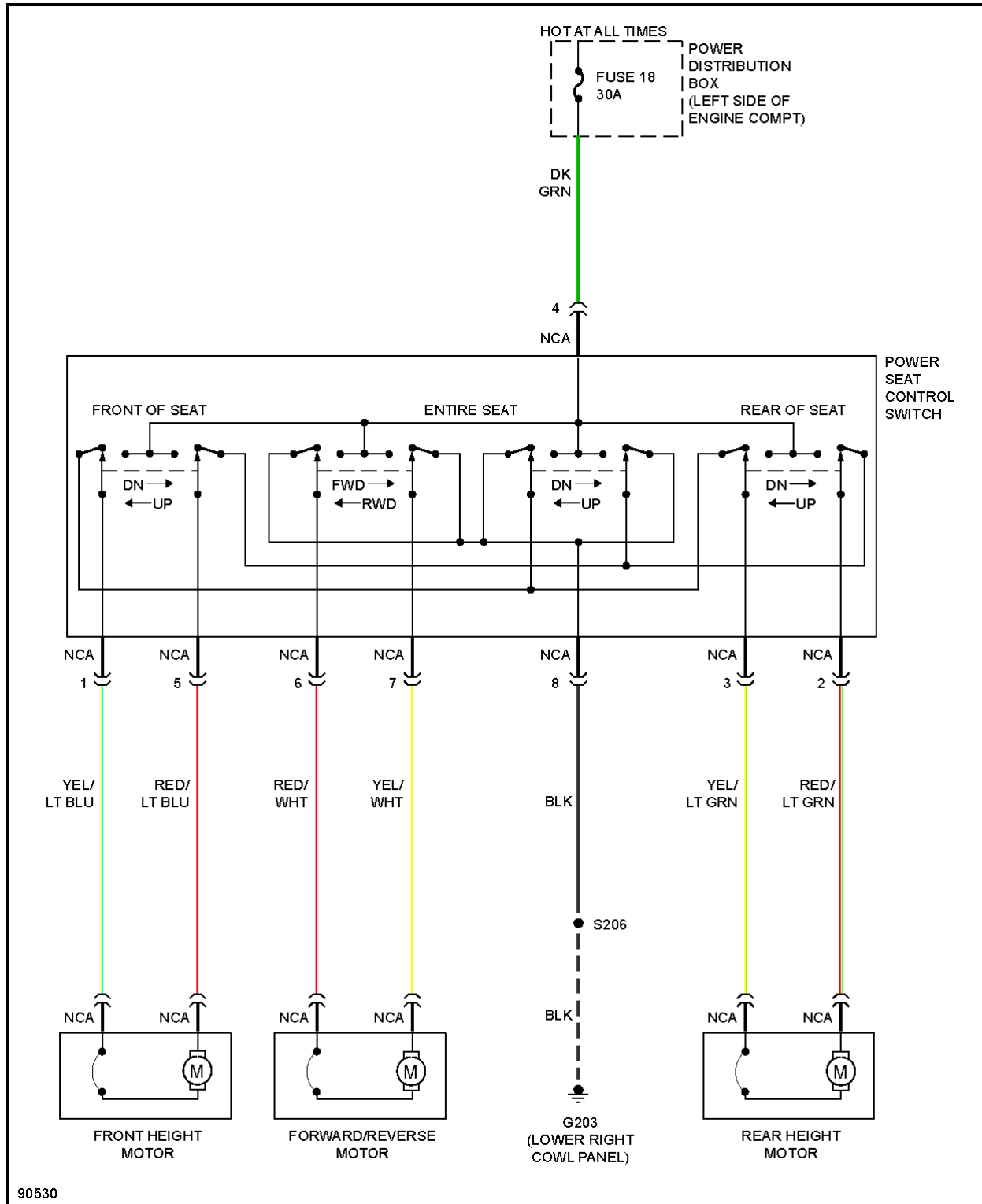

**1997 Ford Pickup F150**

1997 System Wiring Diagrams Ford - Pickup F150

**Fig. 54: Power Seat Circuit**

**POWER WINDOWS**

# 1997 Ford Pickup F150

## 1997 System Wiring Diagrams Ford - Pickup F150

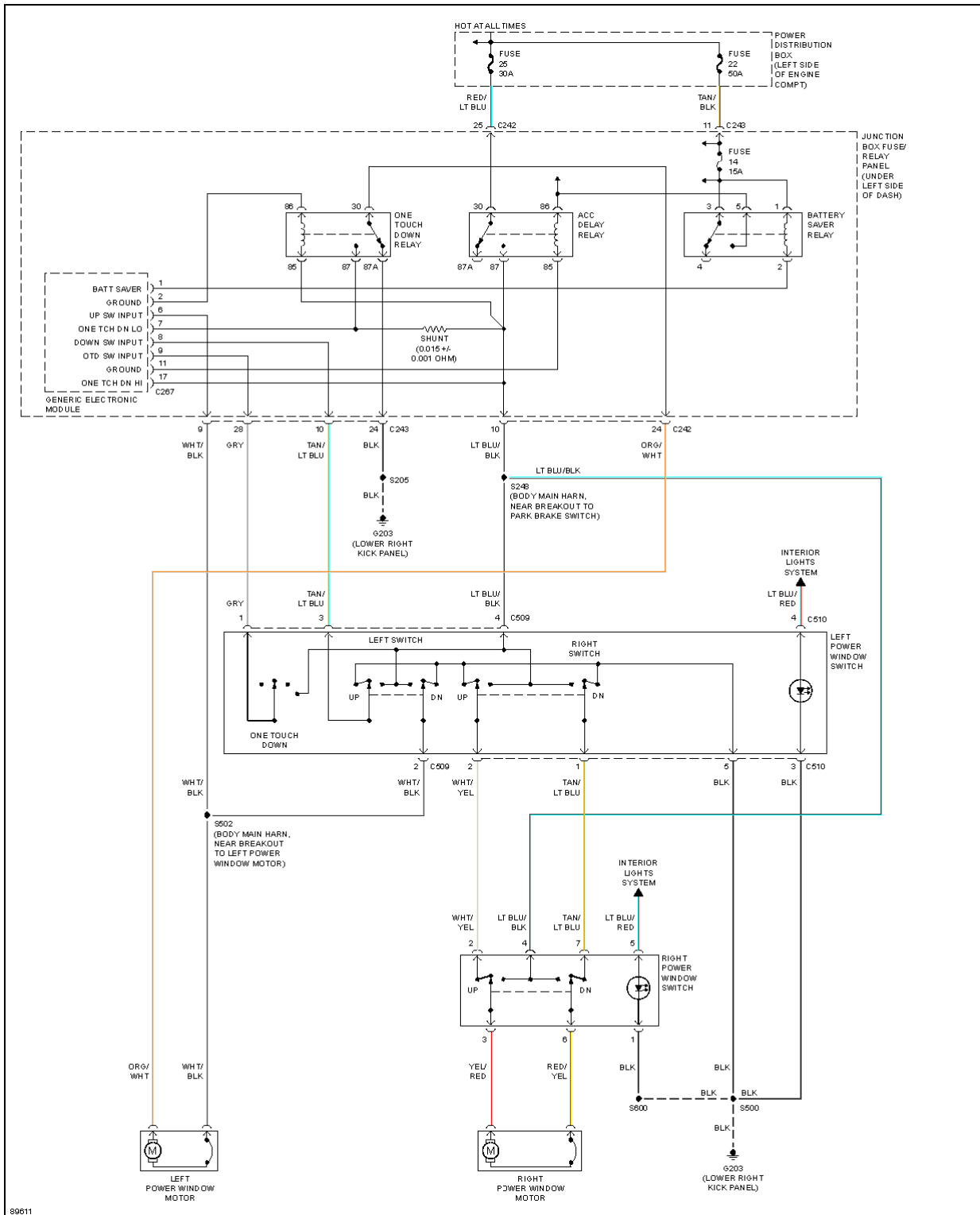

## 1997 Ford Pickup F150

1997 System Wiring Diagrams Ford - Pickup F150

**Fig. 55: Power Window Circuit**

**RADIO**

# 1997 Ford Pickup F150

## 1997 System Wiring Diagrams Ford - Pickup F150

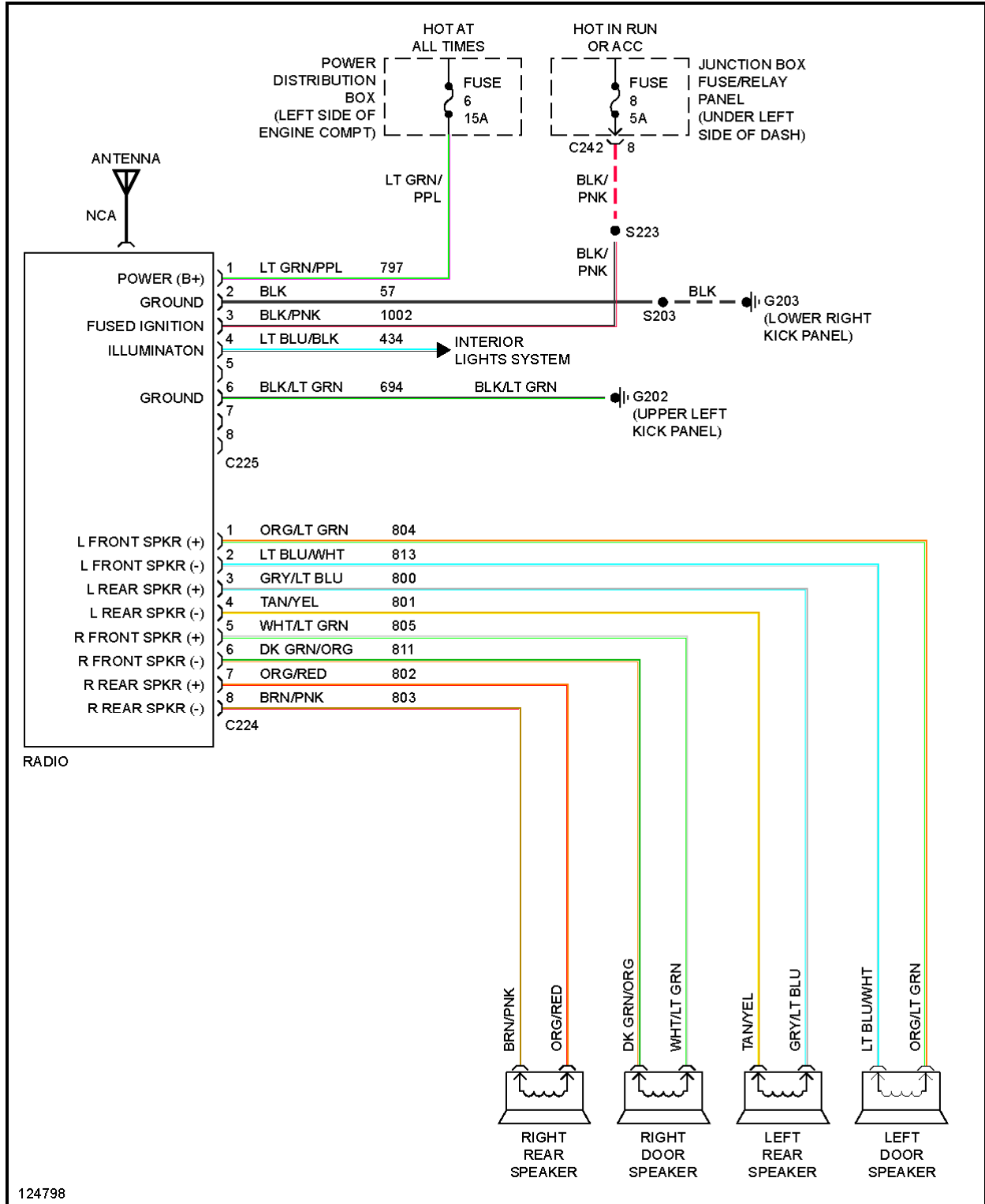



## 1997 Ford Pickup F150

1997 System Wiring Diagrams Ford - Pickup F150

**Fig. 56: Base Radio**

# 1997 Ford Pickup F150

## 1997 System Wiring Diagrams Ford - Pickup F150

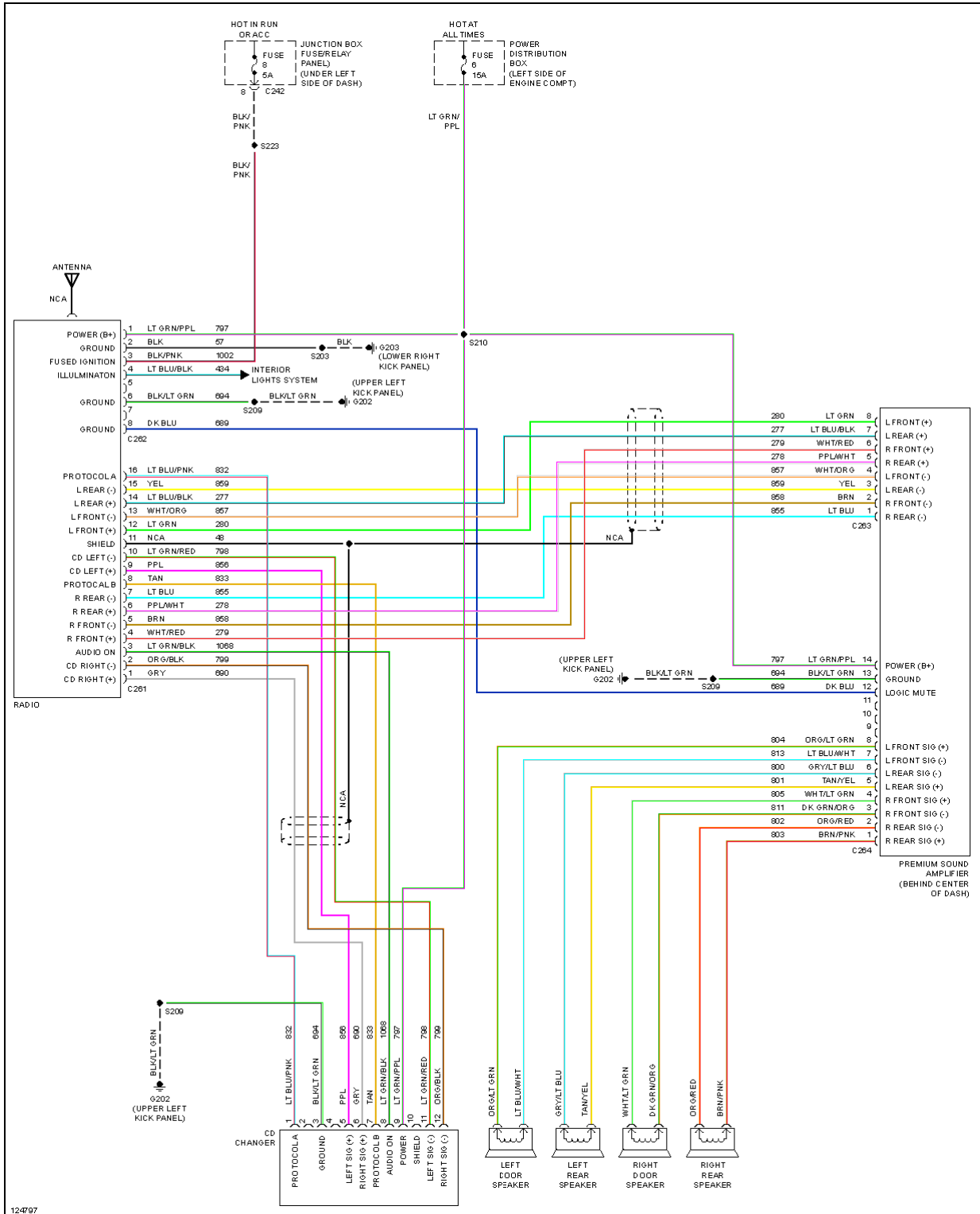

**1997 Ford Pickup F150**

1997 System Wiring Diagrams Ford - Pickup F150

**Fig. 57: Premium Sound Radio Circuit**

**SHIFT INTERLOCKS**

# 1997 Ford Pickup F150

## 1997 System Wiring Diagrams Ford - Pickup F150

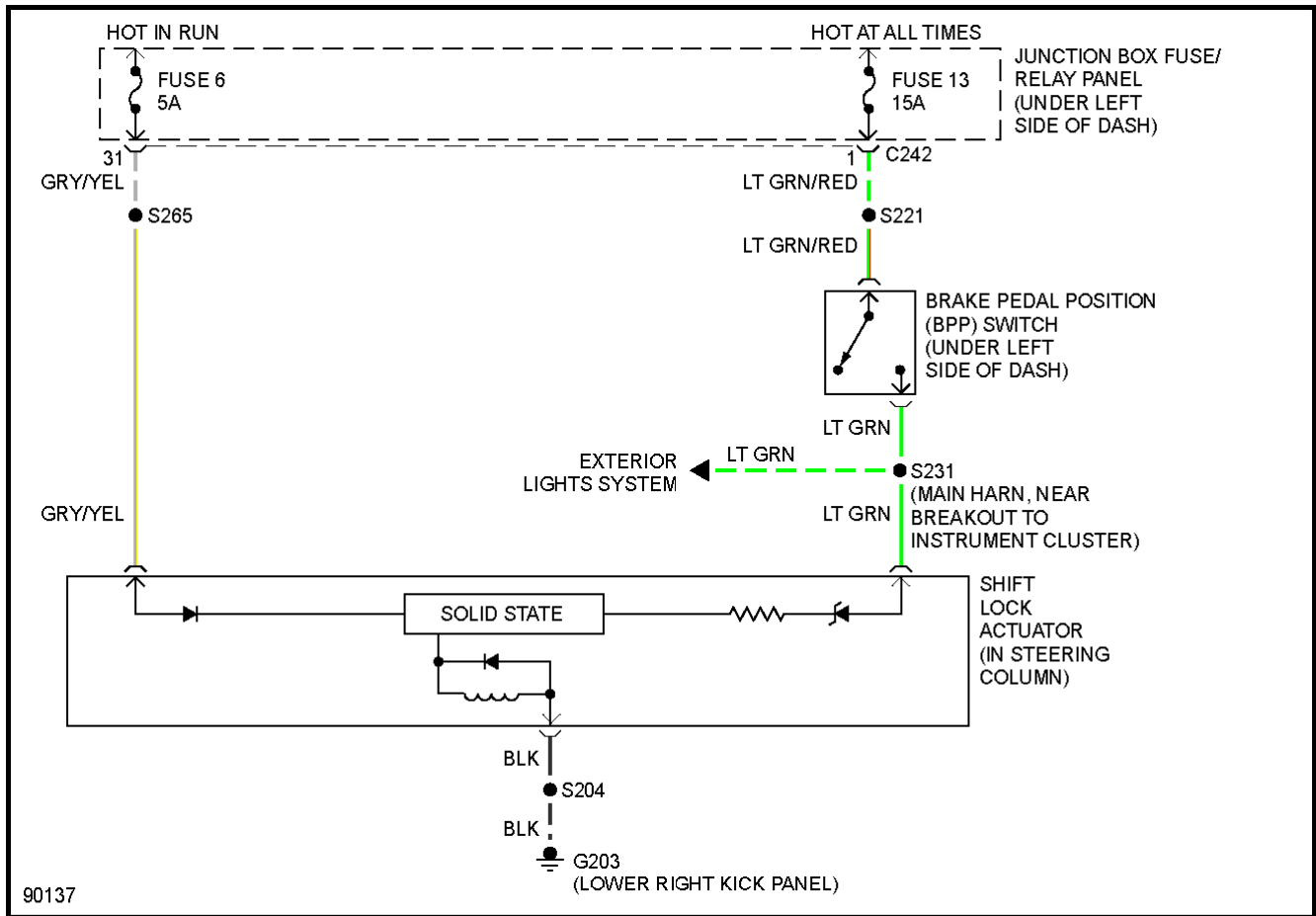

**1997 Ford Pickup F150**

1997 System Wiring Diagrams Ford - Pickup F150

**Fig. 58: Shift Interlock Circuit**

**STARTING/CHARGING**

# 1997 Ford Pickup F150

## 1997 System Wiring Diagrams Ford - Pickup F150

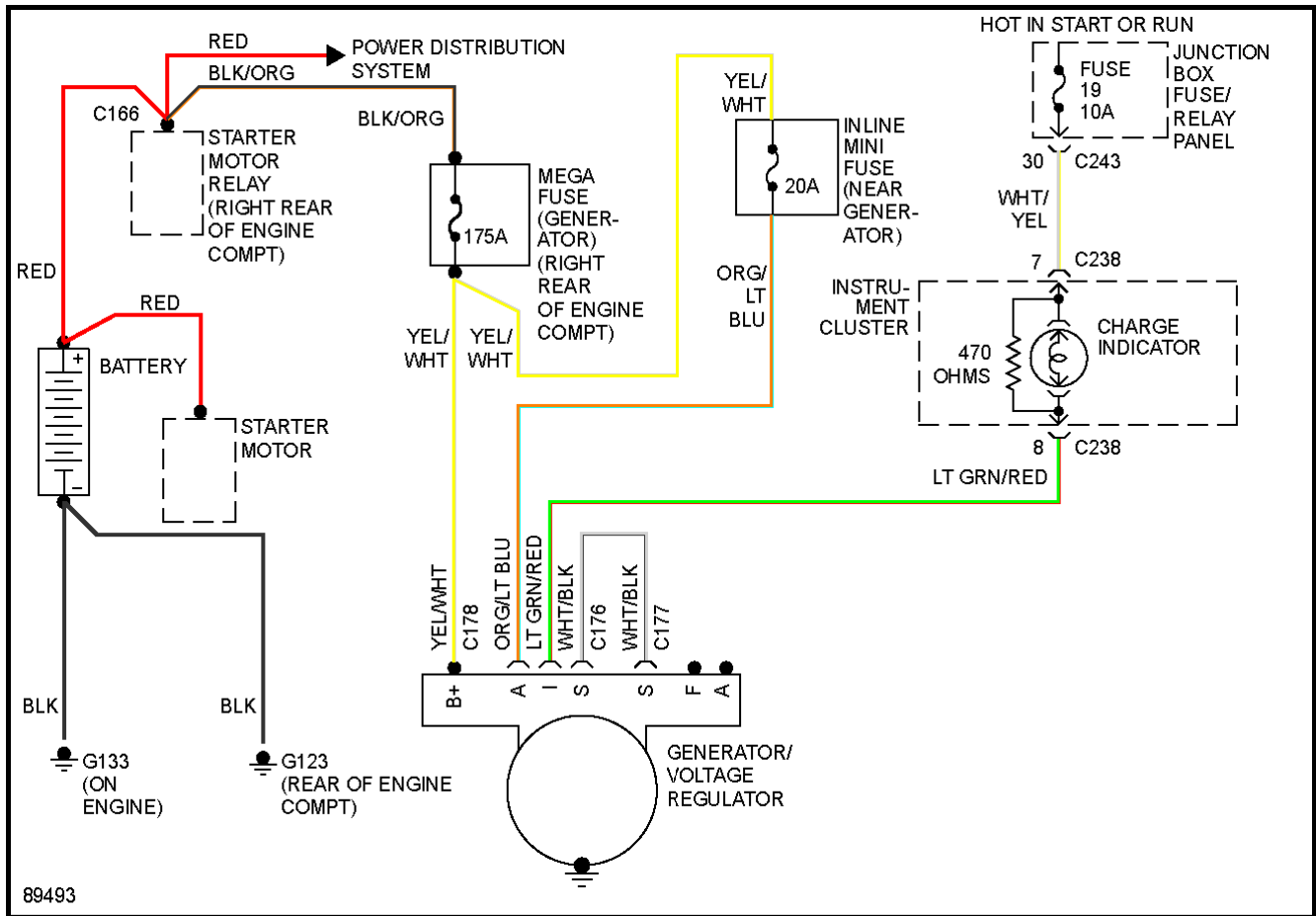

89493

**1997 Ford Pickup F150**

1997 System Wiring Diagrams Ford - Pickup F150

**Fig. 59: Charging Circuit**

# 1997 Ford Pickup F150

## 1997 System Wiring Diagrams Ford - Pickup F150

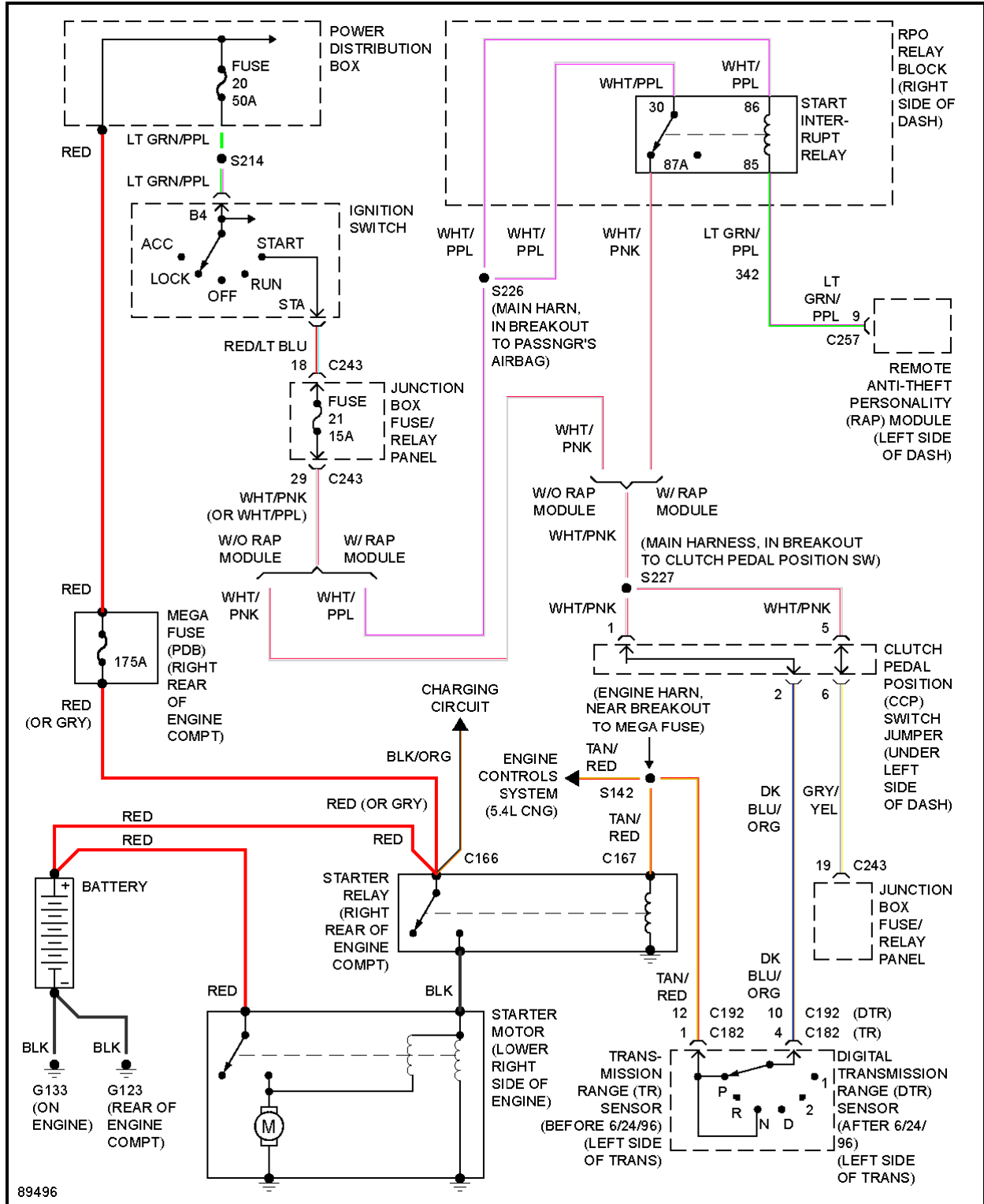



**1997 Ford Pickup F150**

1997 System Wiring Diagrams Ford - Pickup F150

**Fig. 60: Starting Circuit, A/T**

# 1997 Ford Pickup F150

## 1997 System Wiring Diagrams Ford - Pickup F150

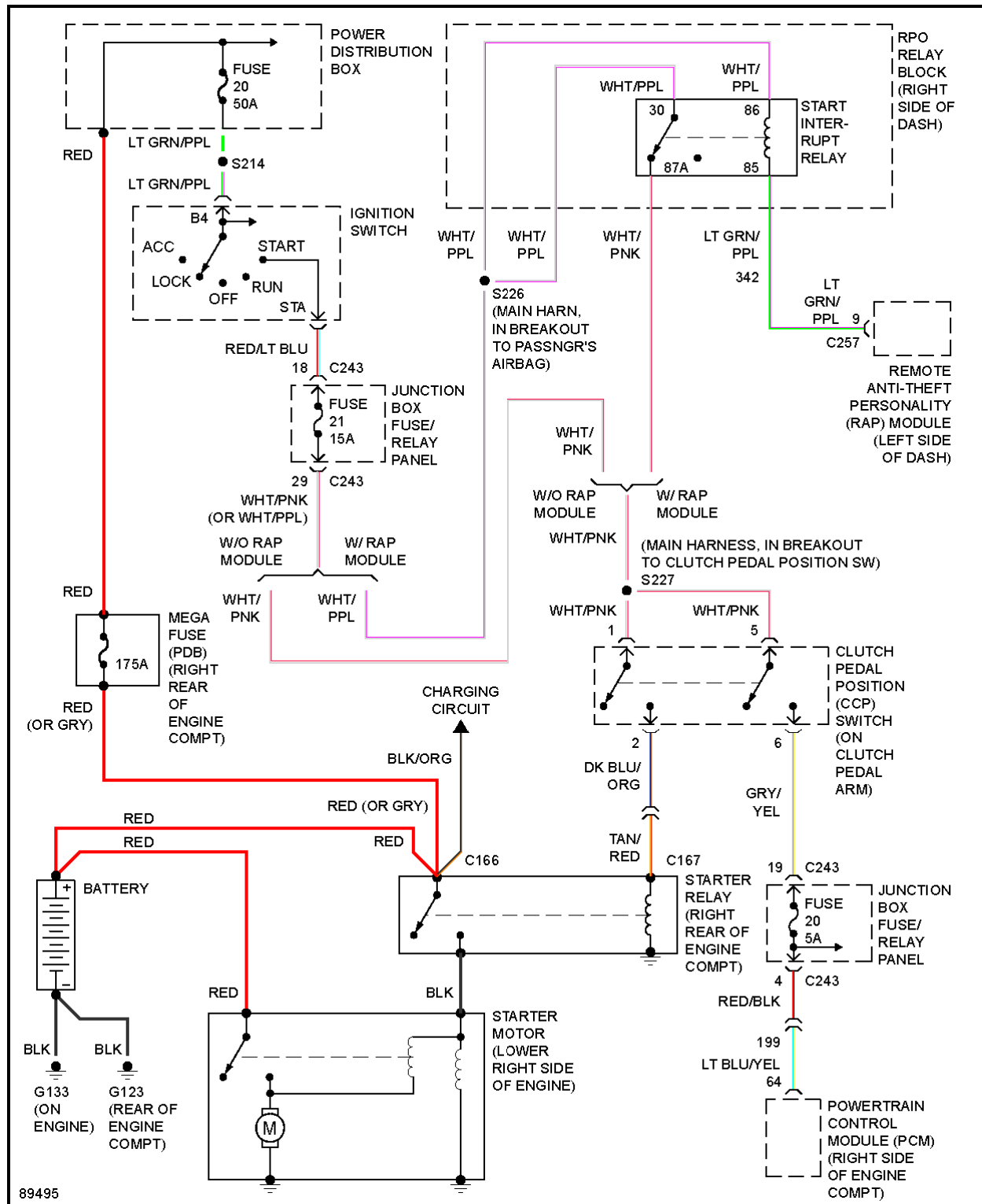

**1997 Ford Pickup F150**

1997 System Wiring Diagrams Ford - Pickup F150

**Fig. 61: Starting Circuit, M/T**

**SUPPLEMENTAL RESTRAINTS**

# 1997 Ford Pickup F150

## 1997 System Wiring Diagrams Ford - Pickup F150

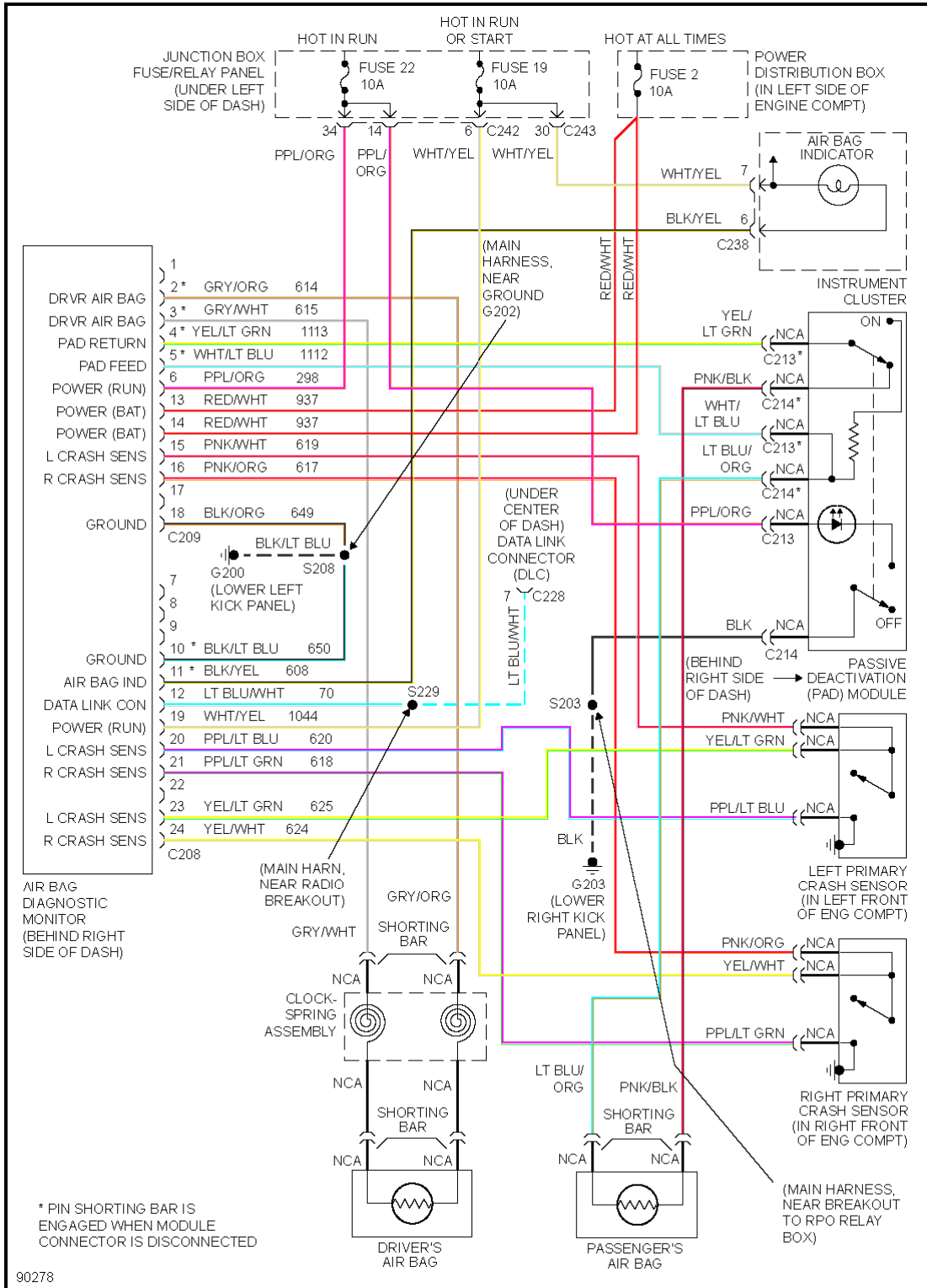

## 1997 Ford Pickup F150

1997 System Wiring Diagrams Ford - Pickup F150

**Fig. 62: Supplemental Restraint Circuit**

### **TRANSMISSION**

**4.2L**

# 1997 Ford Pickup F150

## 1997 System Wiring Diagrams Ford - Pickup F150

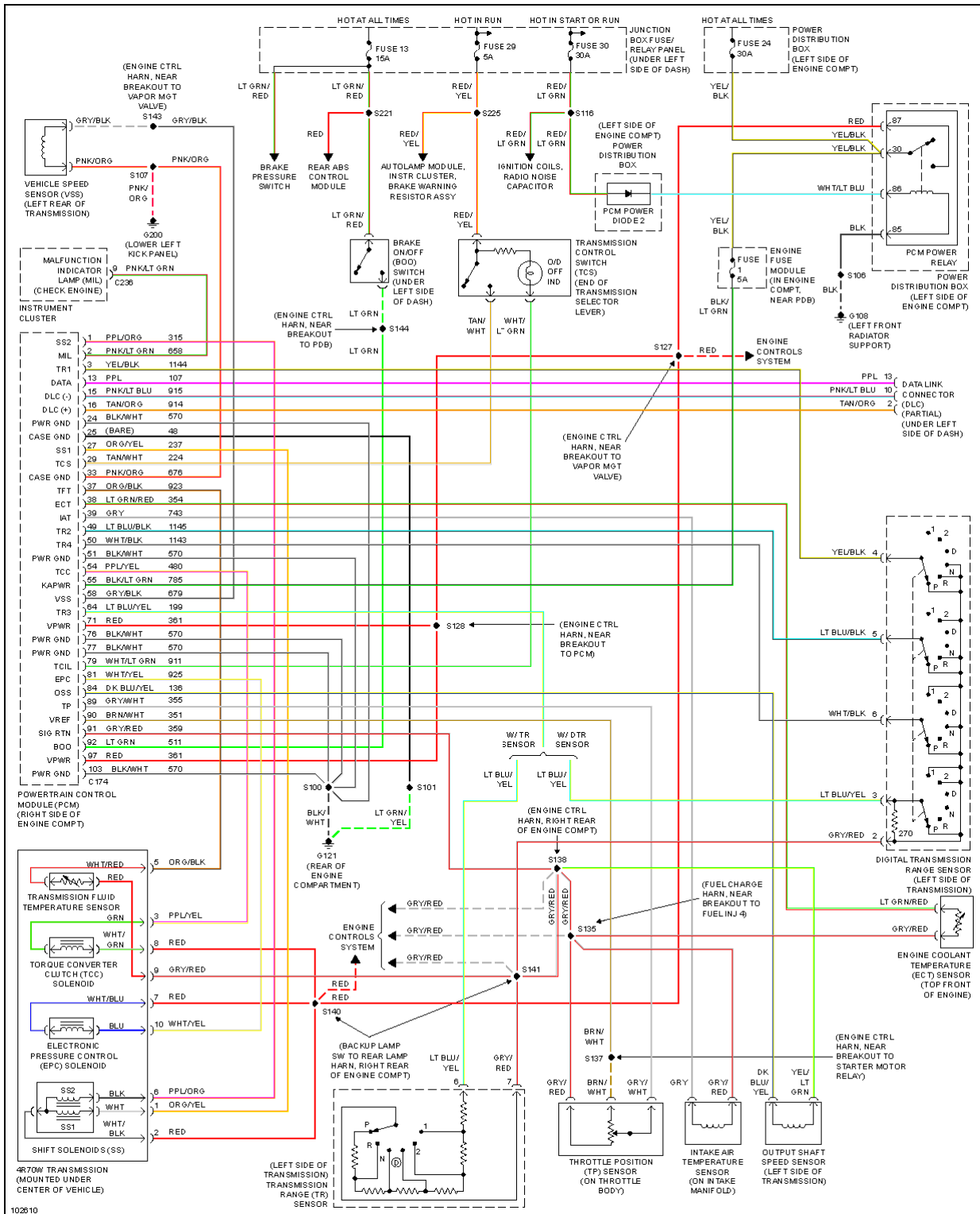

**1997 Ford Pickup F150**

1997 System Wiring Diagrams Ford - Pickup F150

**Fig. 63: 4.2L, Transmission Circuit, 4R70W**

# 1997 Ford Pickup F150

## 1997 System Wiring Diagrams Ford - Pickup F150

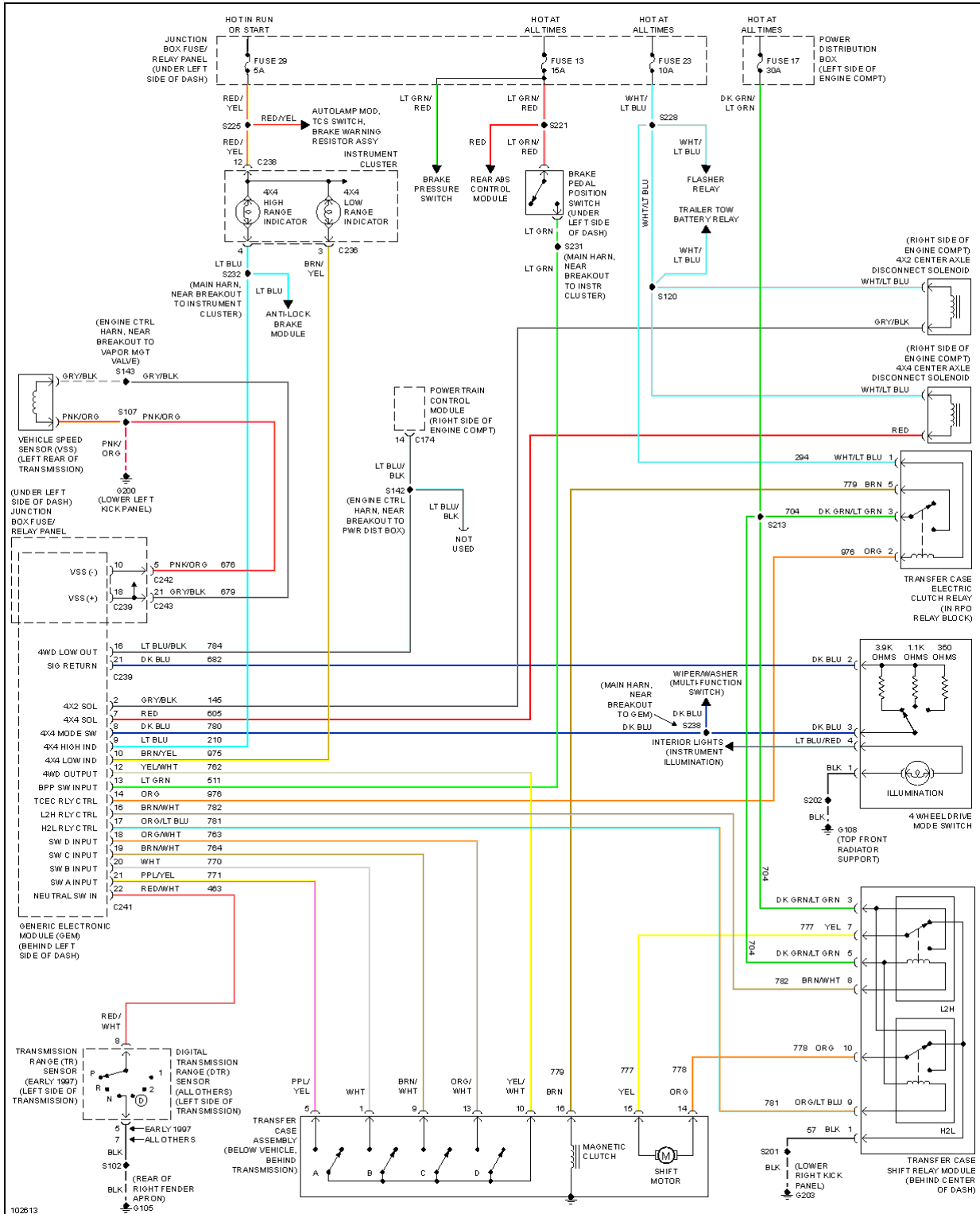



**1997 Ford Pickup F150**

1997 System Wiring Diagrams Ford - Pickup F150

**Fig. 64: Transfer Case Circuit, Electronic**

# 1997 Ford Pickup F150

## 1997 System Wiring Diagrams Ford - Pickup F150

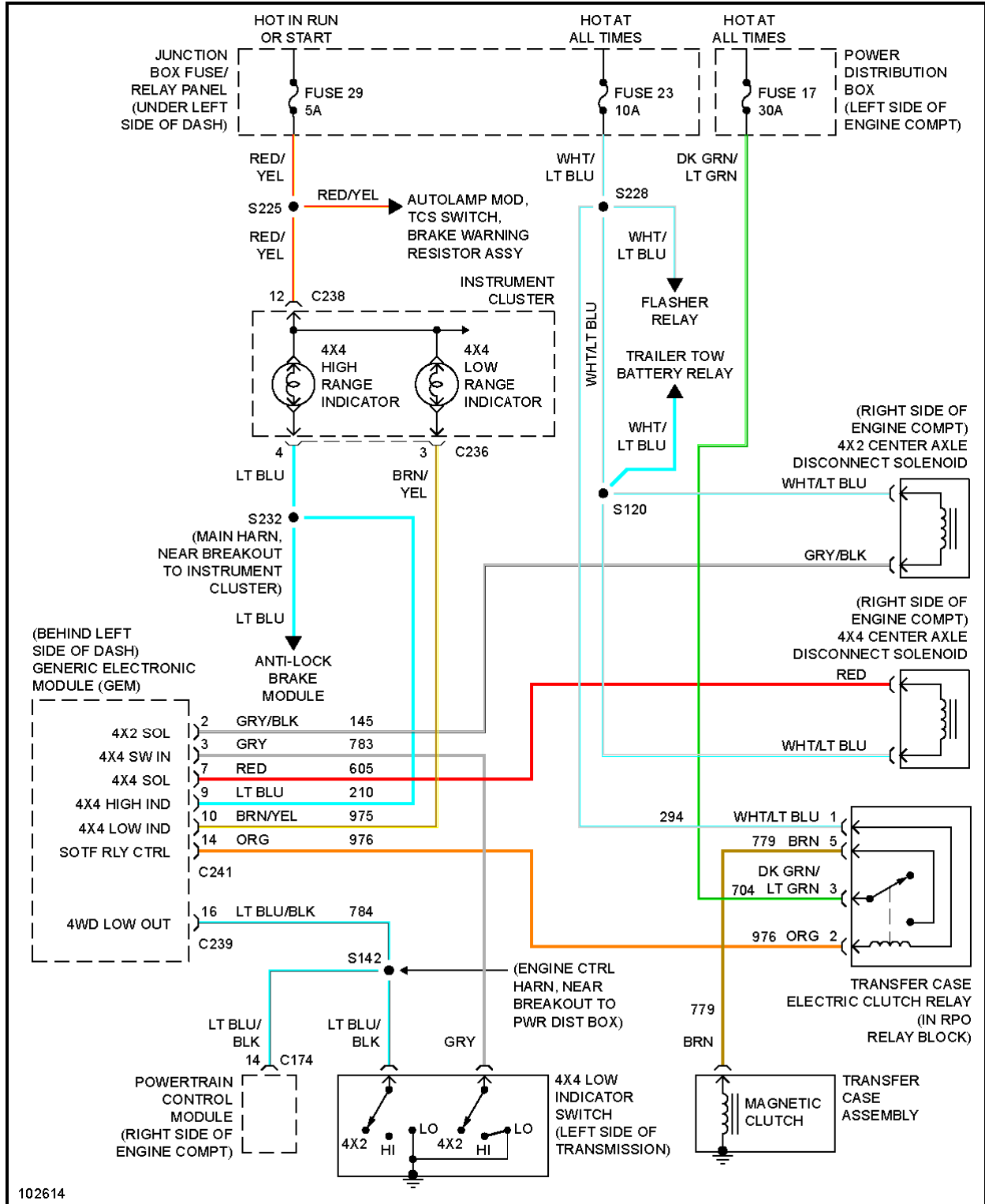

## 1997 Ford Pickup F150

1997 System Wiring Diagrams Ford - Pickup F150

### **Fig. 65: Transfer Case Circuit, Mechanical**

**4.6L**

# 1997 Ford Pickup F150

## 1997 System Wiring Diagrams Ford - Pickup F150

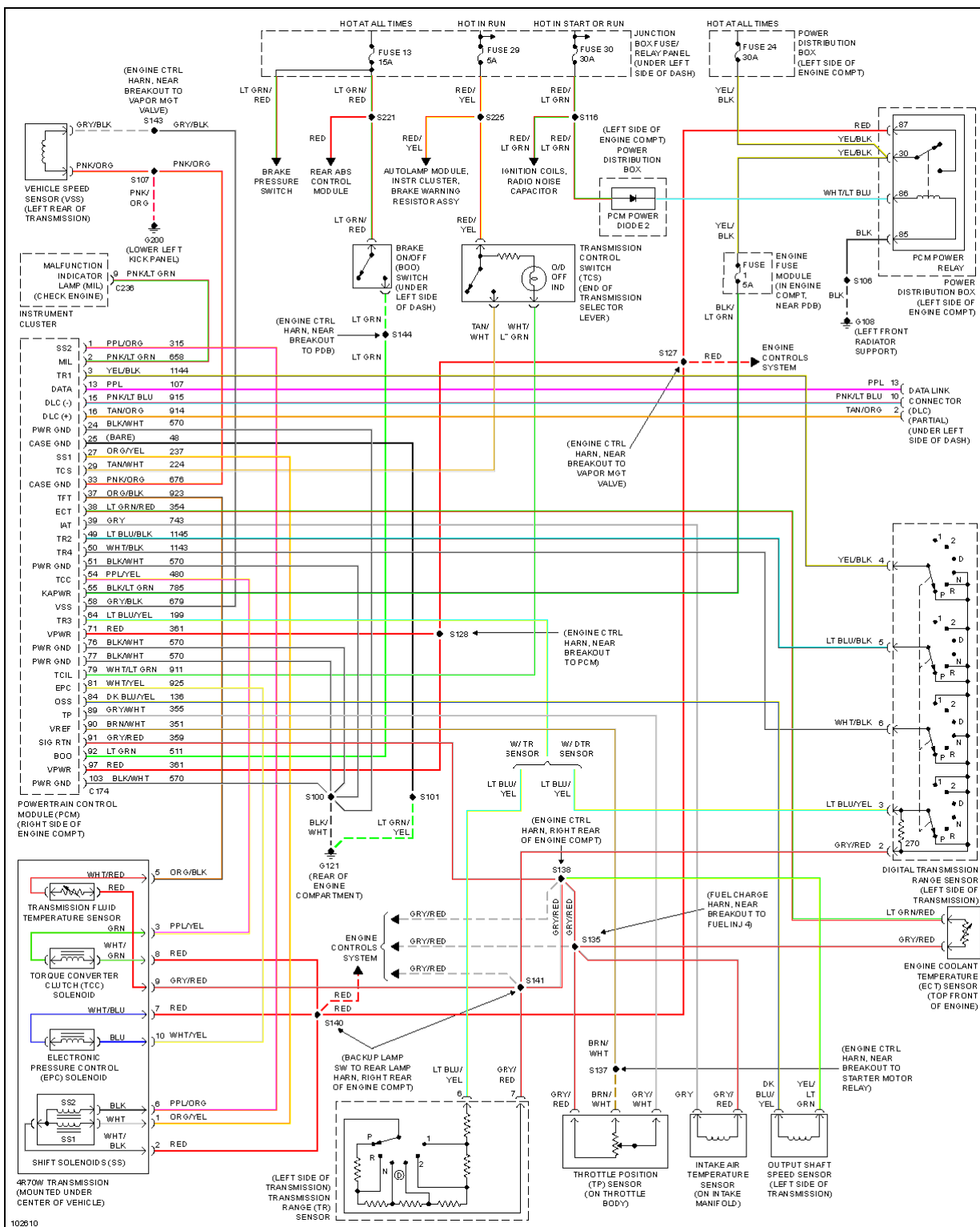

**1997 Ford Pickup F150**

1997 System Wiring Diagrams Ford - Pickup F150

**Fig. 66: 4.6L, Transmission Circuit, 4R70W**

# 1997 Ford Pickup F150

## 1997 System Wiring Diagrams Ford - Pickup F150

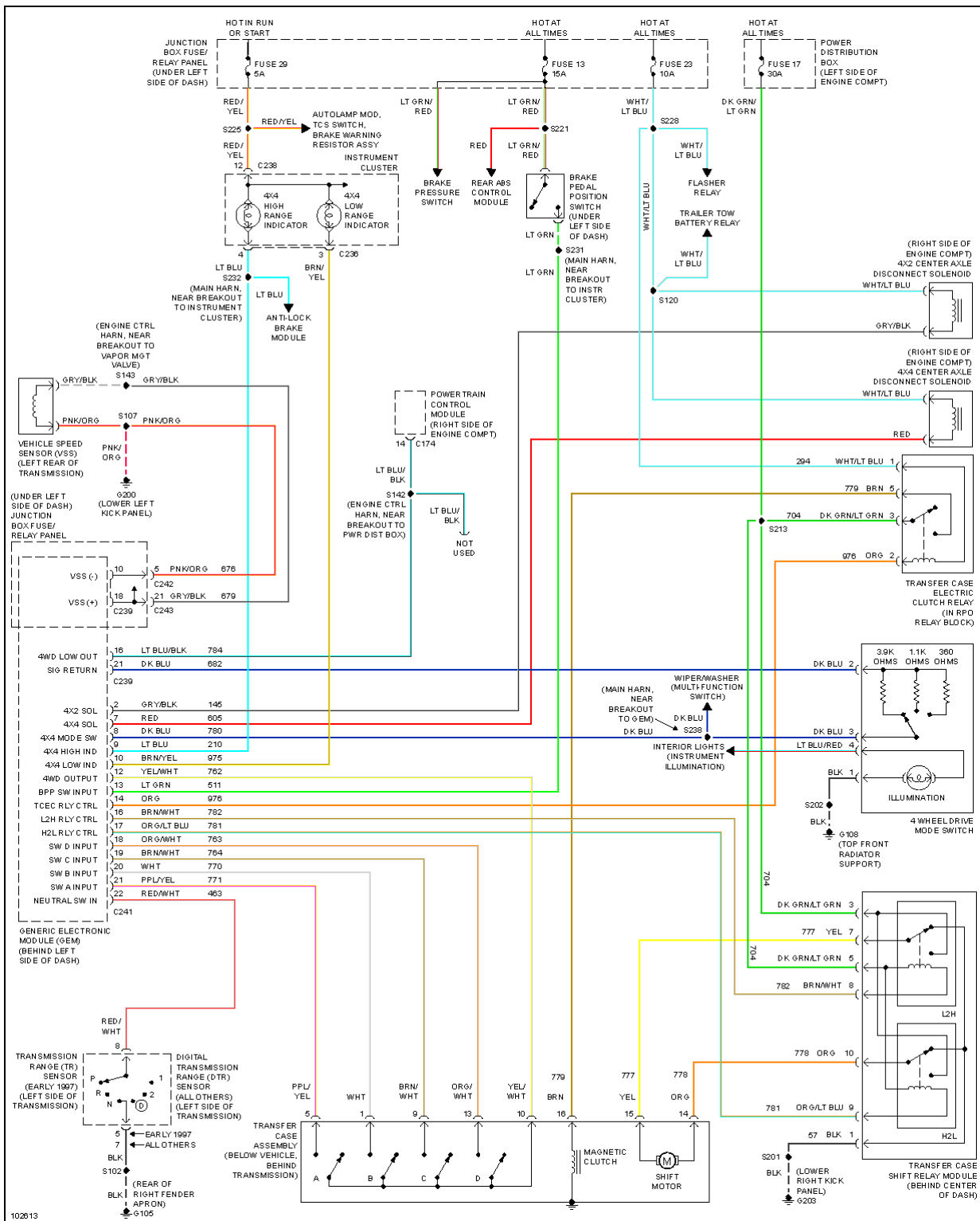

**1997 Ford Pickup F150**

1997 System Wiring Diagrams Ford - Pickup F150

**Fig. 67: Transfer Case Circuit, Electronic**

# 1997 Ford Pickup F150

## 1997 System Wiring Diagrams Ford - Pickup F150

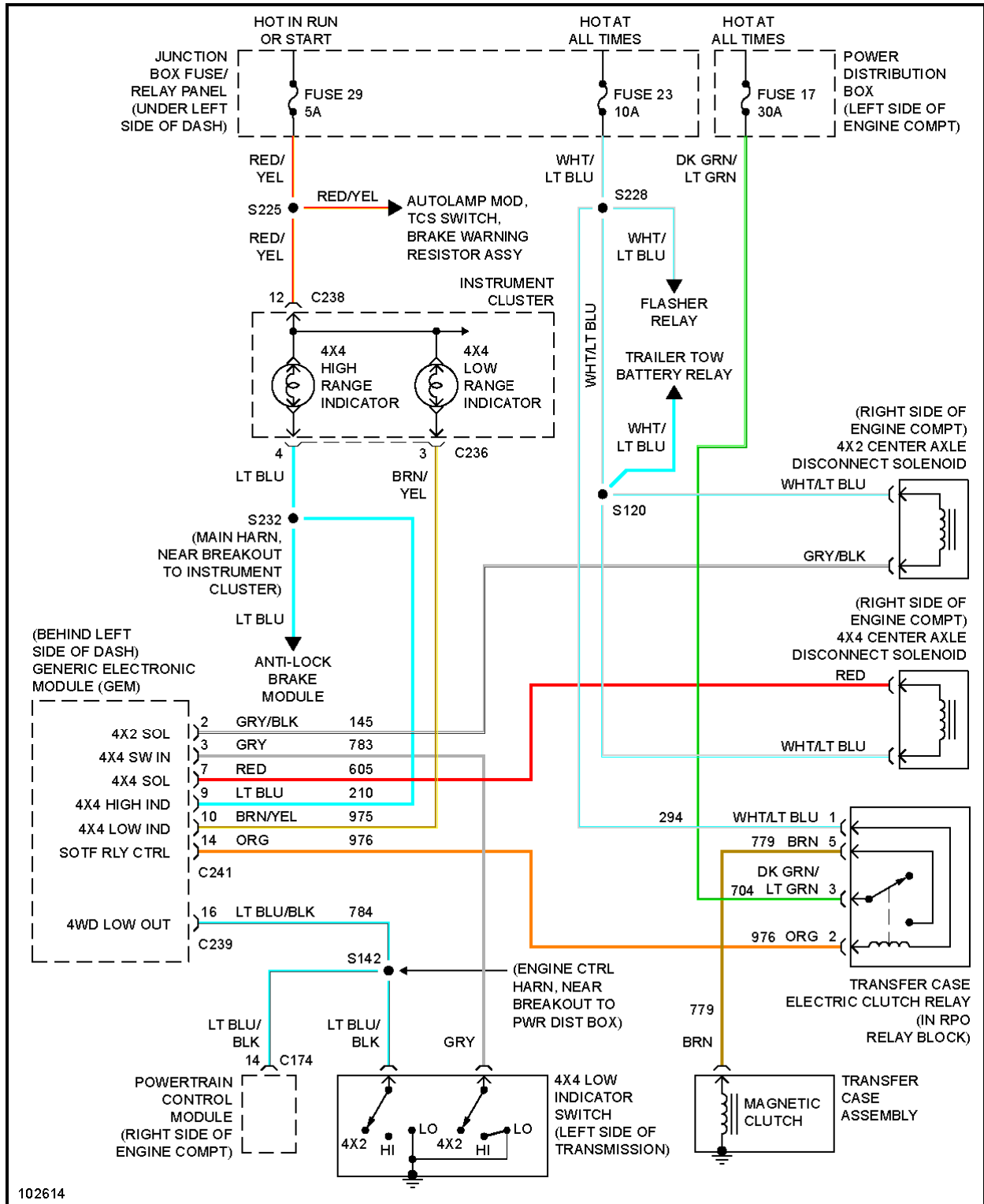



## 1997 Ford Pickup F150

1997 System Wiring Diagrams Ford - Pickup F150

### **Fig. 68: Transfer Case Circuit, Mechanical**

5.4L

# 1997 Ford Pickup F150

## 1997 System Wiring Diagrams Ford - Pickup F150

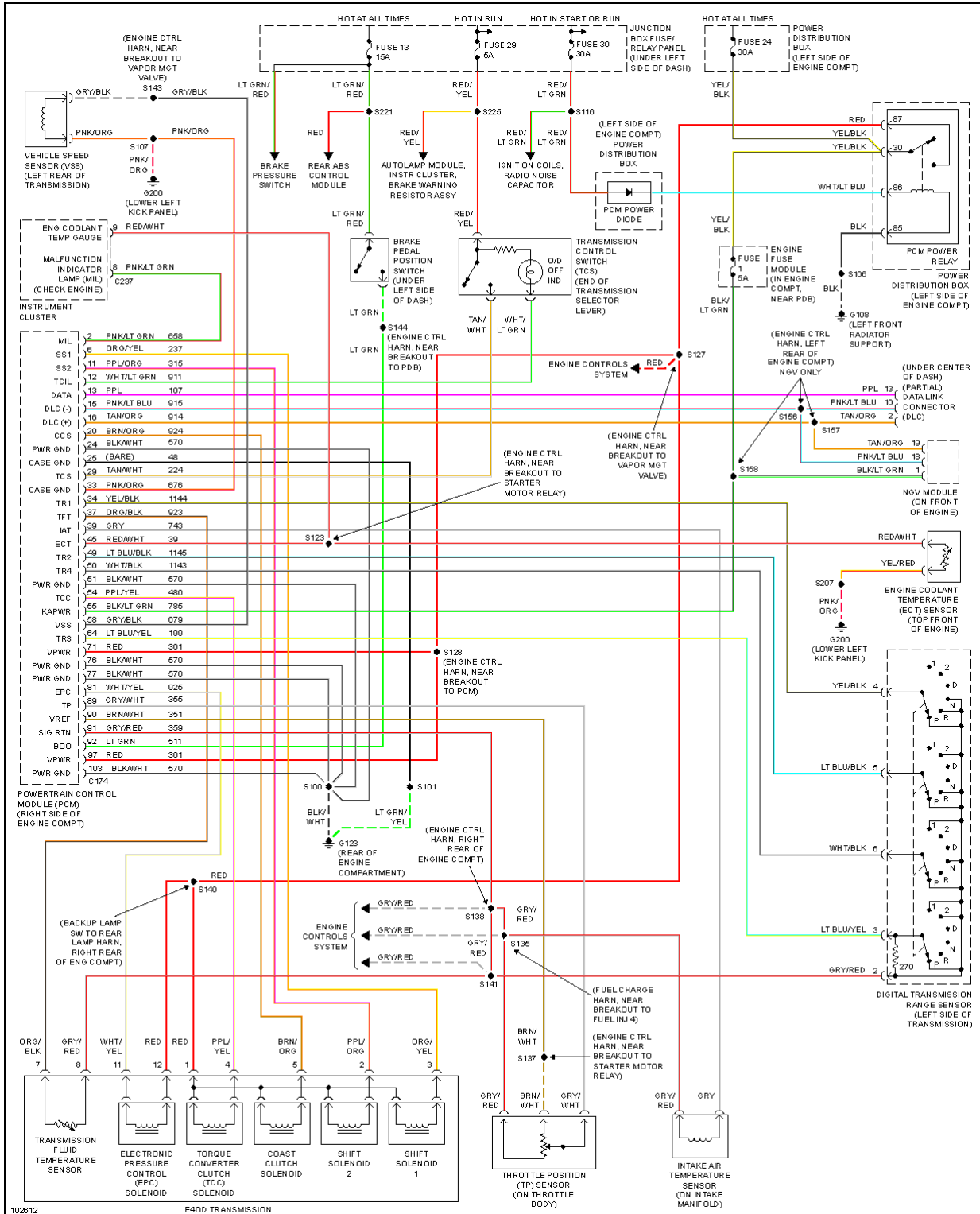

**1997 Ford Pickup F150**

1997 System Wiring Diagrams Ford - Pickup F150

**Fig. 69: 5.4L, Transmission Circuit, E4OD**

# 1997 Ford Pickup F150

## 1997 System Wiring Diagrams Ford - Pickup F150

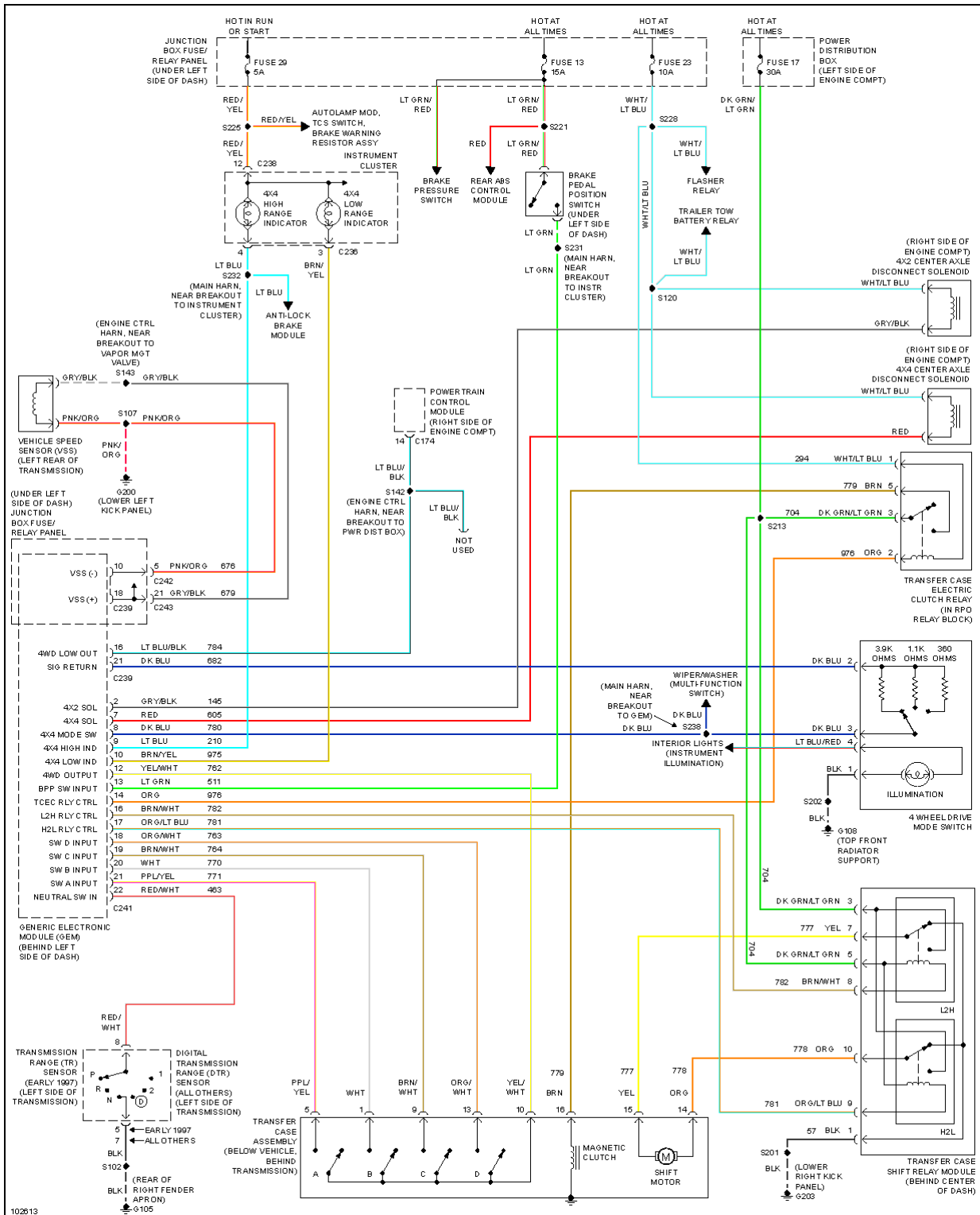

**1997 Ford Pickup F150**

1997 System Wiring Diagrams Ford - Pickup F150

**Fig. 70: Transfer Case Circuit, Electronic**

# 1997 Ford Pickup F150

## 1997 System Wiring Diagrams Ford - Pickup F150

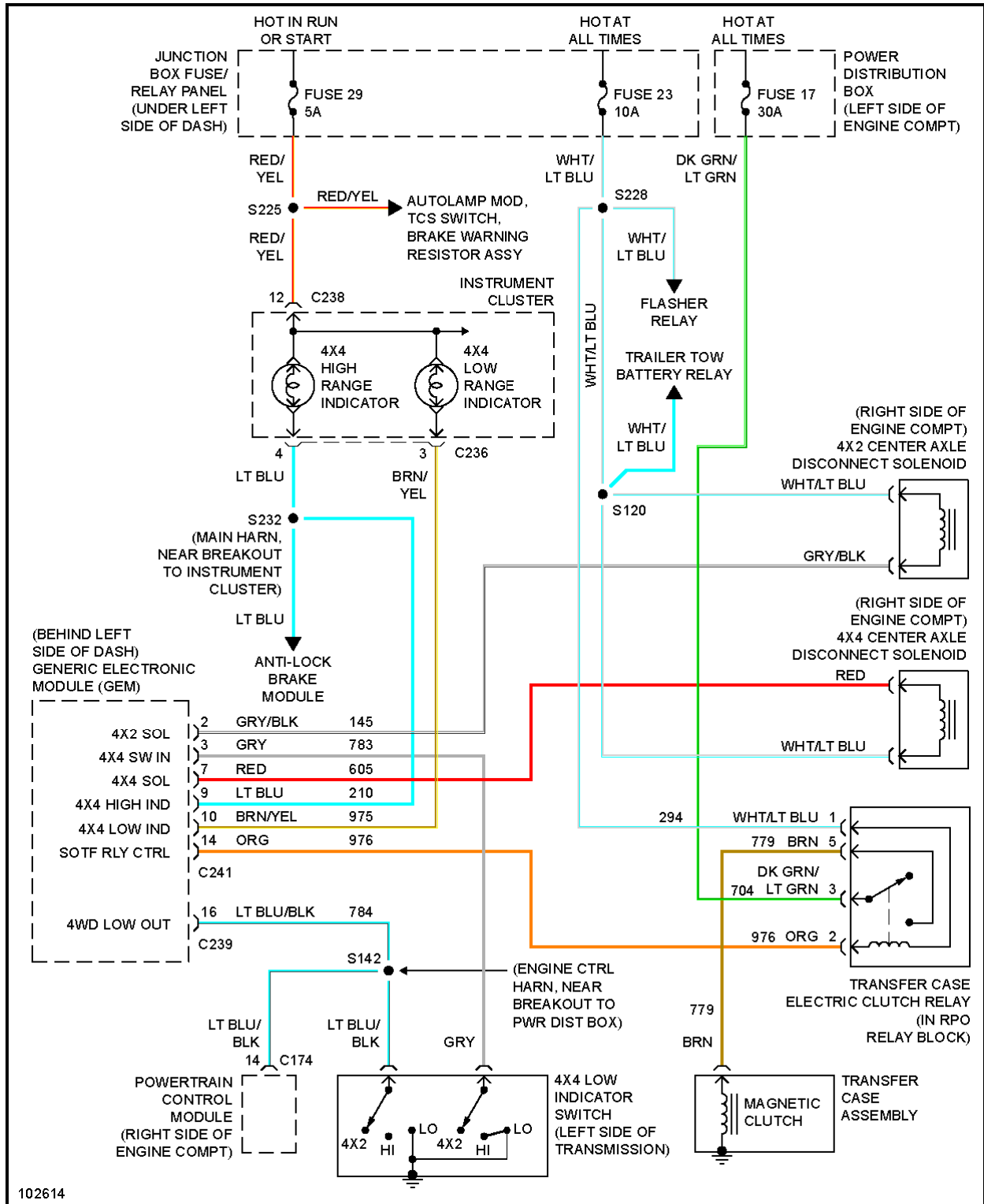

## 1997 Ford Pickup F150

1997 System Wiring Diagrams Ford - Pickup F150

**Fig. 71: Transfer Case Circuit, Mechanical**

### **WARNING SYSTEMS**

# 1997 Ford Pickup F150

## 1997 System Wiring Diagrams Ford - Pickup F150

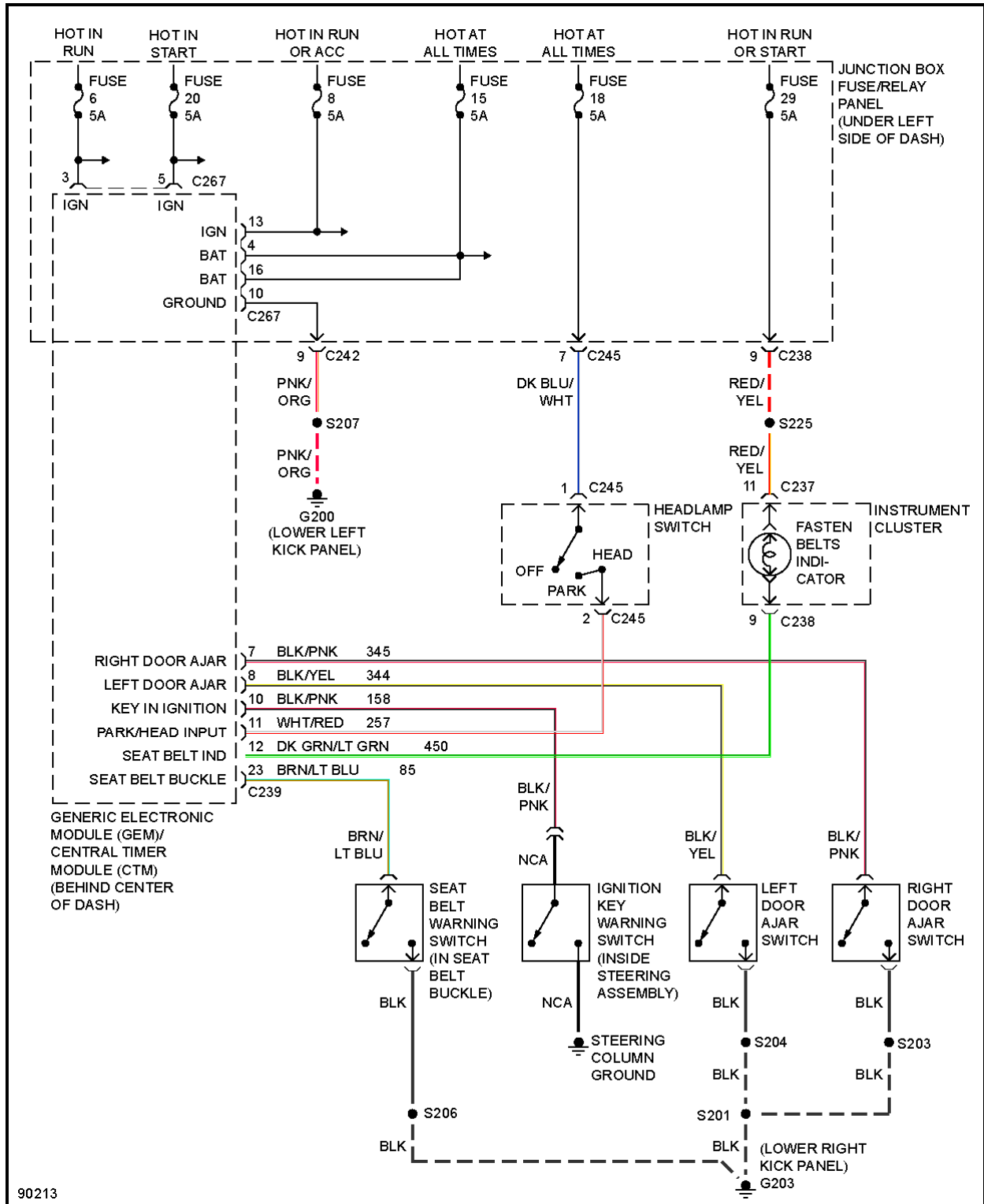



**1997 Ford Pickup F150**

1997 System Wiring Diagrams Ford - Pickup F150

**Fig. 72: Warning System Circuits**

**WIPER/WASHER**

# 1997 Ford Pickup F150

## 1997 System Wiring Diagrams Ford - Pickup F150

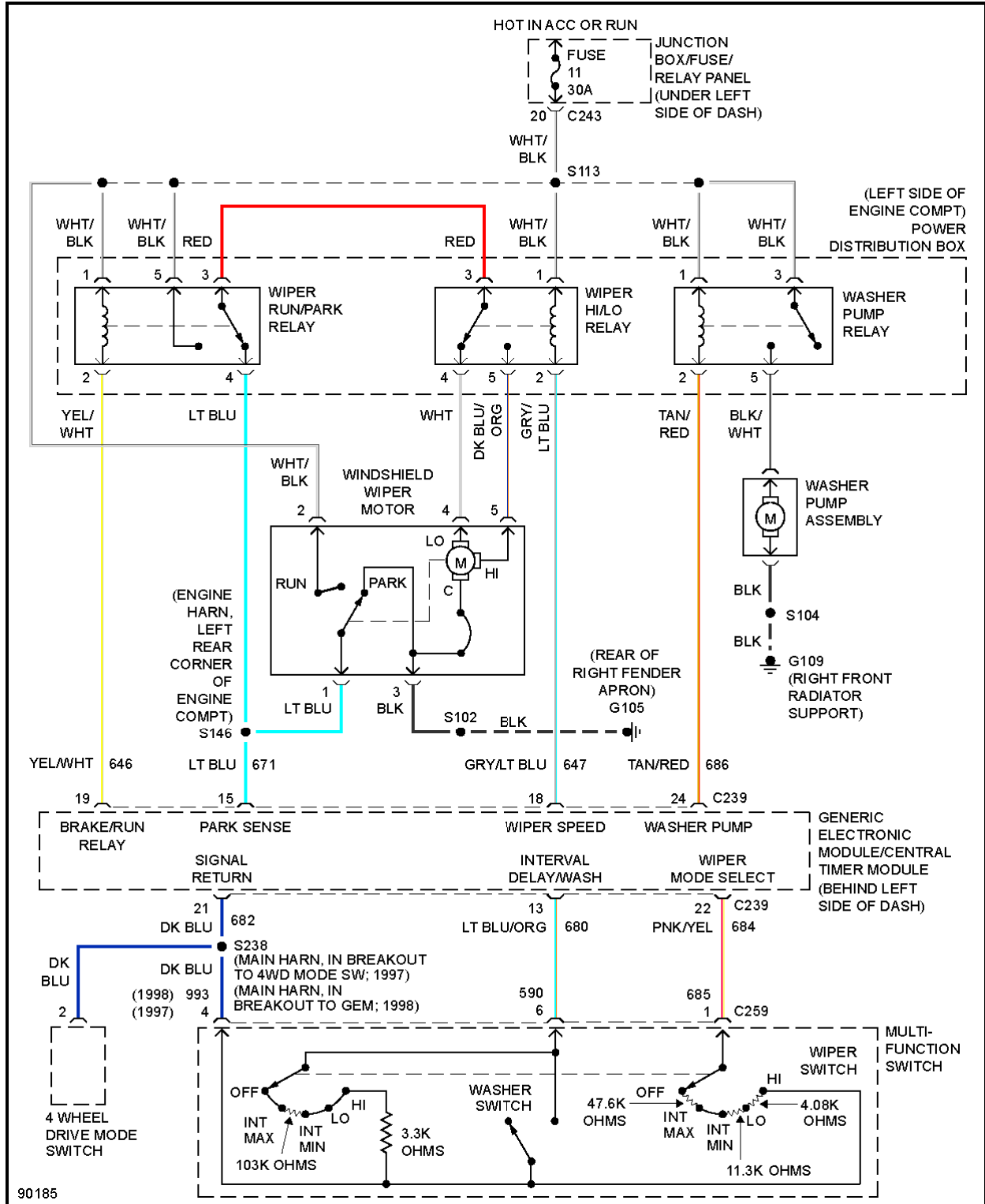

## 1997 Ford Pickup F150

1997 System Wiring Diagrams Ford - Pickup F150

**Fig. 73: Wiper/Washer Circuit**