

ATTENTION PACKAGERS

**IMPORTANT -
TEMPLATE IS
INCLUDED IN THIS
INSTRUCTION SHEET,
IT MUST BE
PRINTED AT 100%**

INSTRUCTION SHEET FOR EXTERNAL REMOTE START ANTENNA (RSA) THAT IS CONNECTED TO TIRE PRESSURE MODULE (TPM) TO BE RELOCATED ONTO THE HEADLINER FOR F-SERIES 2013 – 2014 MODEL YEARS

KIT		
Part Number	Description	Quantity
FL3T-18D816-EC	RSA Relocation Kit	1
FL3T-14A614-AA	RSA Coax Cable	1
FL3T-14B207-AB	Template	1
95873-S	Tie Straps	8
SKFL3T-14B207-AC	Instruction Sheet	1

SERVICE PROCEDURE:

1. Remove passenger side instrument panel trim so you can gain access to TPM (CL3T-18D816-AB). Open and Lower Glove Box to gain access to RSA module (BL3T-14B207-AA). Refer to Workshop Manual (WSM) Section 204-04.
2. Remove RSA Coax Cable (BL3T-14A614-BA) that connects the RSA (BL3T-14B207-AA) to TPM (CL3T-18D816-AB), Disconnect both electrical connectors, remove wire retaining push pins and discard cable. (Refer to Figures 1 and 2).
3. Remove RSA (BL3T-14B207-AA) from the vehicle, by removing the two (2) bolts and then remove the two (2) Copper Snap-In nuts from both ends of the module. Remove two (2) Push-Pin Fasteners from the two (2) ends from the RSA module and discard. (Refer to Figure 2).

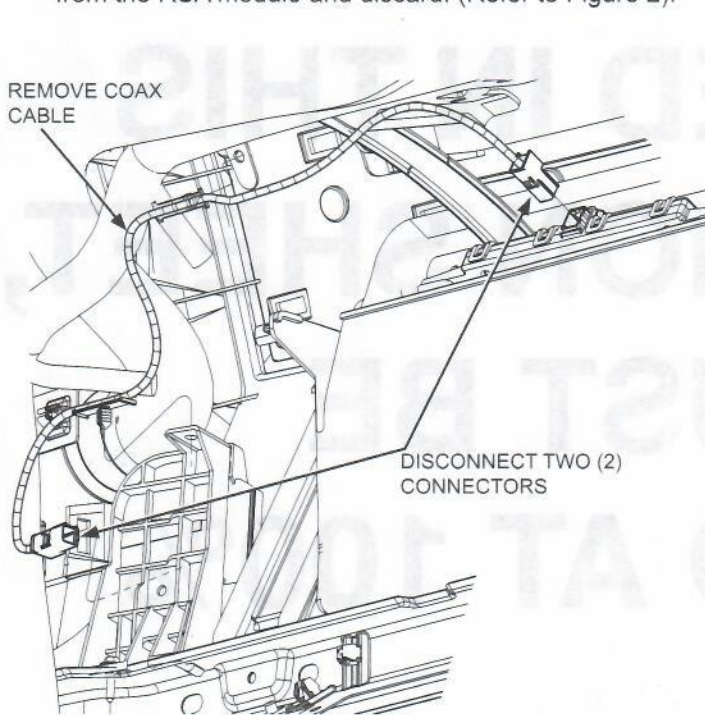

FIGURE 1

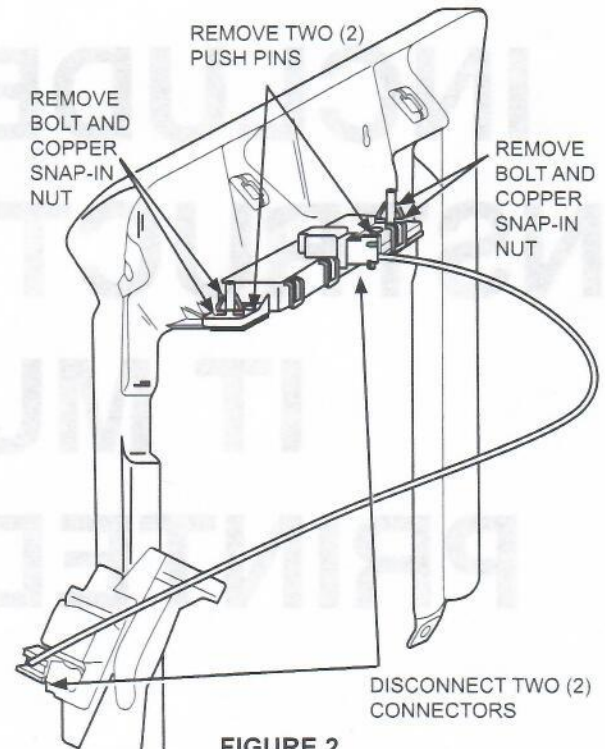

FIGURE 2

SKFL3T-14B207-AC

SHEET 1 OF 5



4. Lower the headliner using the Workshop Manual (WSM) Section 501-05. (Refer to Figure 3).

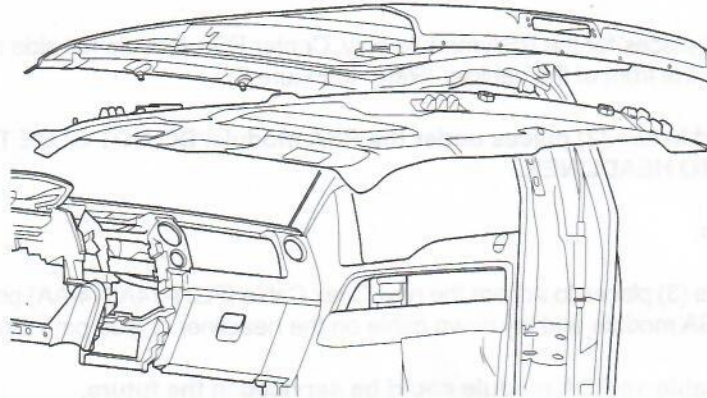

FIGURE 3

NOTE: For Vehicles with center Over Head Council, (mostly on vehicles with moon roof), you need to modify the Over Head Council (OHC) Mounting Bracket.

5. Remove the two (2) screws holding the plastic OHC Mounting bracket. (Refer to Figure 4).

6. This bracket has two side extensions arms. Cut the passenger side arm of the bracket using a hacksaw on the bench approximately 6-5/16" (16cm) from the end of arm. Mark the bracket cut line on the passenger side extension cut section and discard. (Refer to Figure 4, View A).

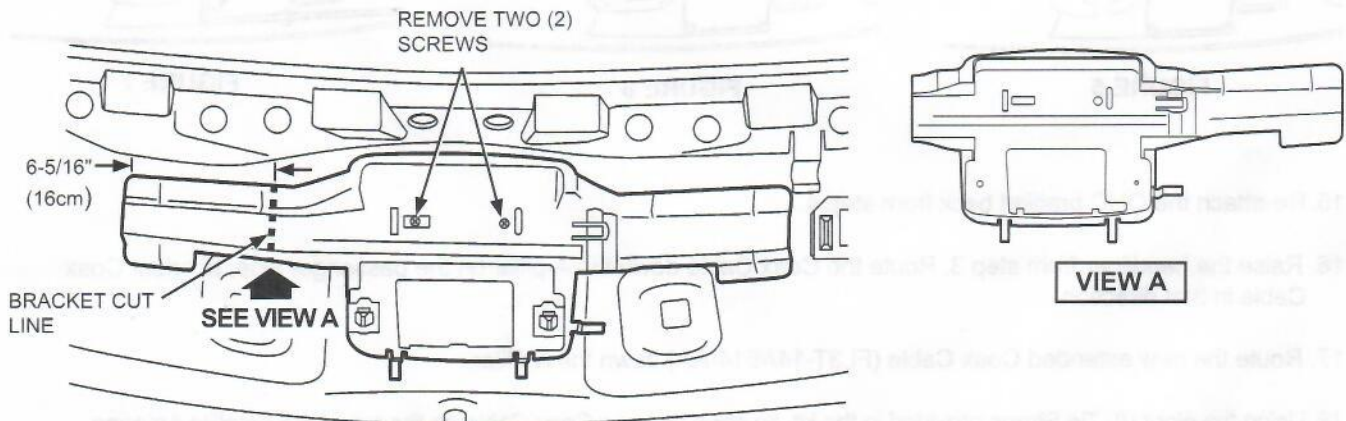

FIGURE 4

7. Using the RSA module from step 2, attach the module to the headliner above the Passenger Sun Visor.

8. Cut out template (FL3T-14B207-AB) on page 5. Cut out five (5) glue holes and rectangular hole.

9. Using template (FL3T-14B207-AB) and align over rectangular hole in the headliner for the mounting of the sun visor clip on the passenger side. Use scotch tape to hold the template on the headliner. Mark holes for glue and discard template. (Refer to Figure 5).

SKFL3T-14B207-AC

SHEET 2 OF 5



CPR © 2015 FORD MOTOR COMPANY
DEARBORN, MICHIGAN 48121

1-15

INSTRUCTION SHEET FOR EXTERNAL REMOTE START
ANTENNA (RSA) THAT IS CONNECTED TO TIRE
PRESSURE MODULE (TPM) TO BE
RELOCATED ONTO THE HEADLINER FOR
F-SERIES 2013 – 2014 MODEL YEARS

10. Obtain 3M™ Duramix™ 4747 Super Fast Adhesive commercially to attach the RSA module to the headliner. The 3M™ Duramix™ 4747 Super Fast Adhesive is a 2-part adhesive in a 50ml dual-tube applicator.
11. First apply Glue in two (2) places for the RSA module only. Center RSA module flat side down on the headliner with connector pointing to the front of the vehicle. (Refer to Figure 6).

NOTE: Glue is only applied in two (2) places under the RSA module. DO NOT GLUE THE ENTIRE BOTTOM OF RSA MODULE TO HEADLINER.

12. Let Glue dry for 5 minutes.

13. Next apply the glue in three (3) places to adhere the new Coax Cable (FL3T-14A614-AA) provided in the kit. Plug one end of the connector to RSA module and lay down cable on the headliner in glue path provided from the template.

NOTE: Leave slack in the cable so RSA module could be serviced in the future.

14. Let Glue dry for 5 minutes.

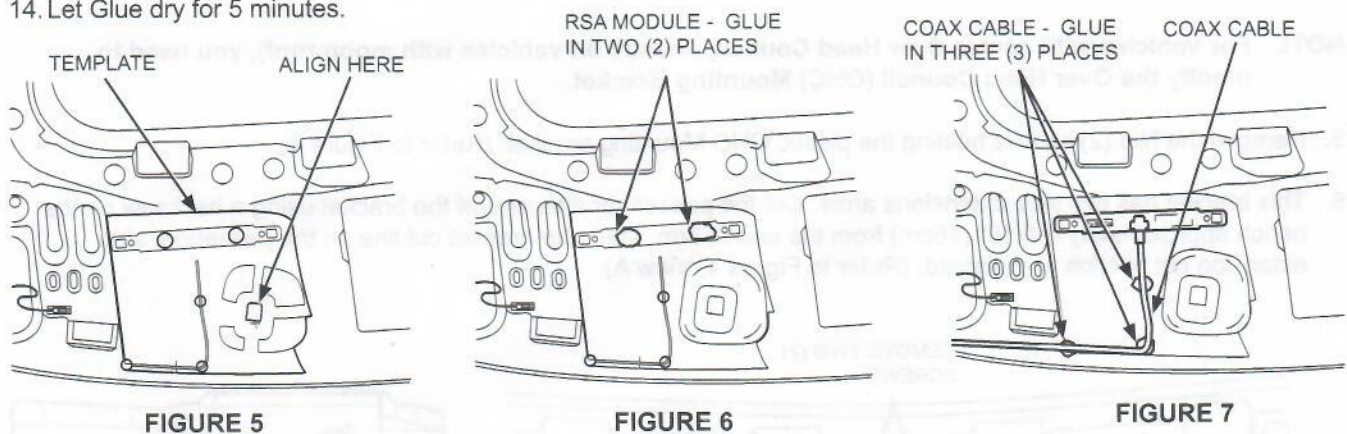

15. Re-attach the OHC bracket back from step 4.

16. Raise the headliner from step 3. Route the Coax Cable down the A-pillar on the passenger side, to orient Coax Cable in that direction.

17. Route the *new* extended Coax Cable (FL3T-14A614-AA) down the A Pillar.

18. Using the eight (8) Tie Straps provided in the kit, tie strap the *new* Coax Cable on the top of the Satellite Antenna Cable down the A pillar. (Refer to Figures 11, 12 and 13).

19. Finally connect the Coax Cable Connector into the TPM (CL3T-18D816-AB) making sure it snaps in place so it does not come open. Secure the Coax Cable using the Tie Straps from the kit.

CAUTION: THE TPM IS SNAPPED INTO ITS BRACKET SO WHILE TRYING TO PLUG IN THE CONNECTOR FROM COAX CABLE, MAKE SURE THE TPM IS NOT UNSNAPPED FROM ITS BRACKET.

SKFL3T-14B207-AC

SHEET 3 OF 5



CPR © 2015 FORD MOTOR COMPANY
DEARBORN, MICHIGAN 48121
1-15

INSTRUCTION SHEET FOR EXTERNAL REMOTE START ANTENNA (RSA) THAT IS CONNECTED TO TIRE PRESSURE MODULE (TPM) TO BE RELOCATED ONTO THE HEADLINER FOR F-SERIES 2013 – 2014 MODEL YEARS

20. Re-assemble the vehicle following headliner. Refer to WSM, Section 501-05.

21. Install the passenger side instrument panel trim and glove box. Refer to WSM Section 204-04.

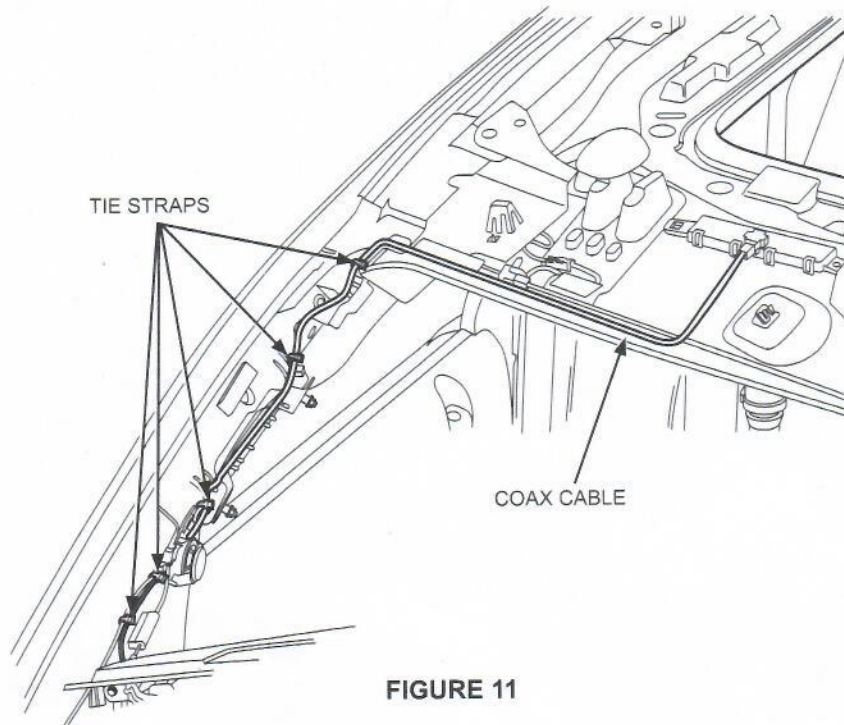

FIGURE 11

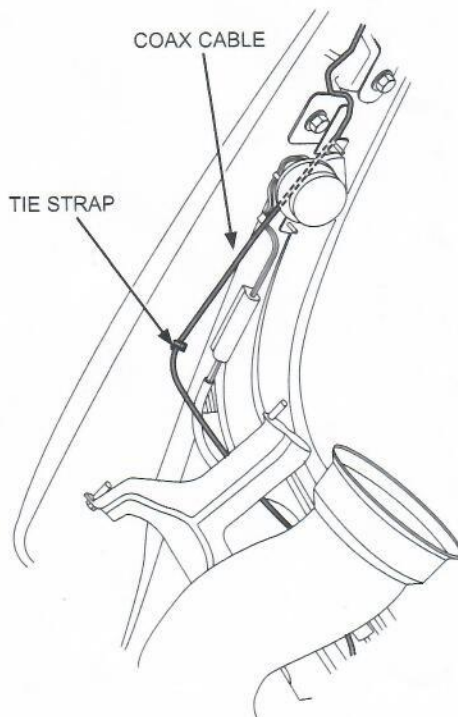

FIGURE 12

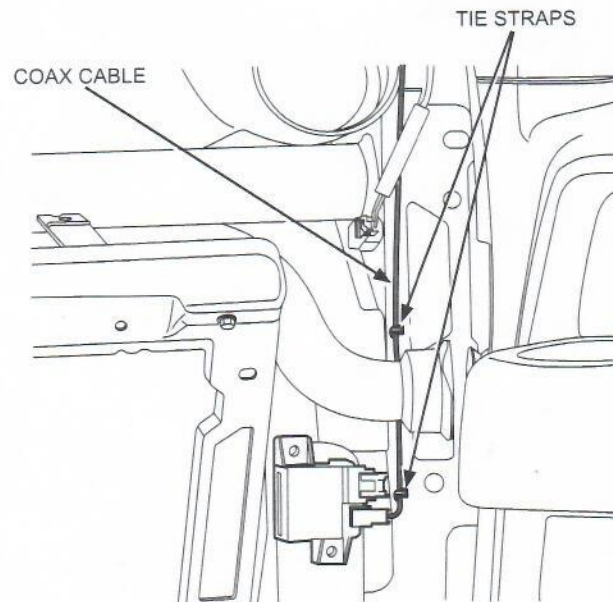
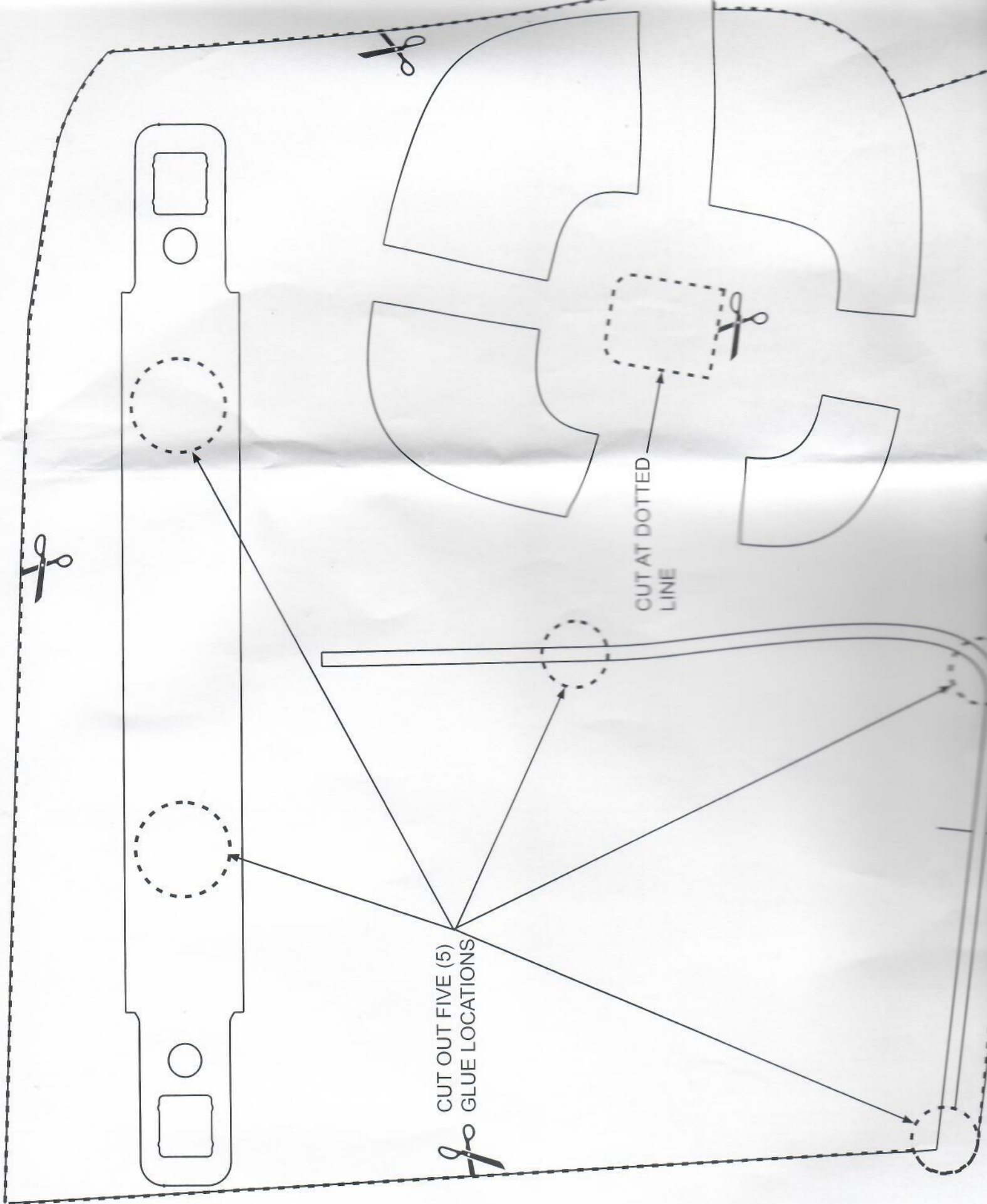

FIGURE 13





CUT AT DOTTED
LINE

CUT OUT FIVE (5)
GLUE LOCATIONS