

Engine Oil Draining and Filling

Special Tool(s) / General Equipment

Oil Drain Equipment

Draining

1. With the vehicle in NEUTRAL, position it on a hoist.
Refer to: [Jacking and Lifting - Overview](#) (100-02 Jacking and Lifting, Description and Operation).
2. **NOTE:** Use a shop towel when removing the oil filter housing to prevent oil from spilling on the engine or accessory components.
 1. Loosen the oil filter housing and allow the oil to drain out of the housing and down into the engine.
 2. Remove the oil filter housing and discard the oil filter element.
 3. Remove and discard the O-ring seals.

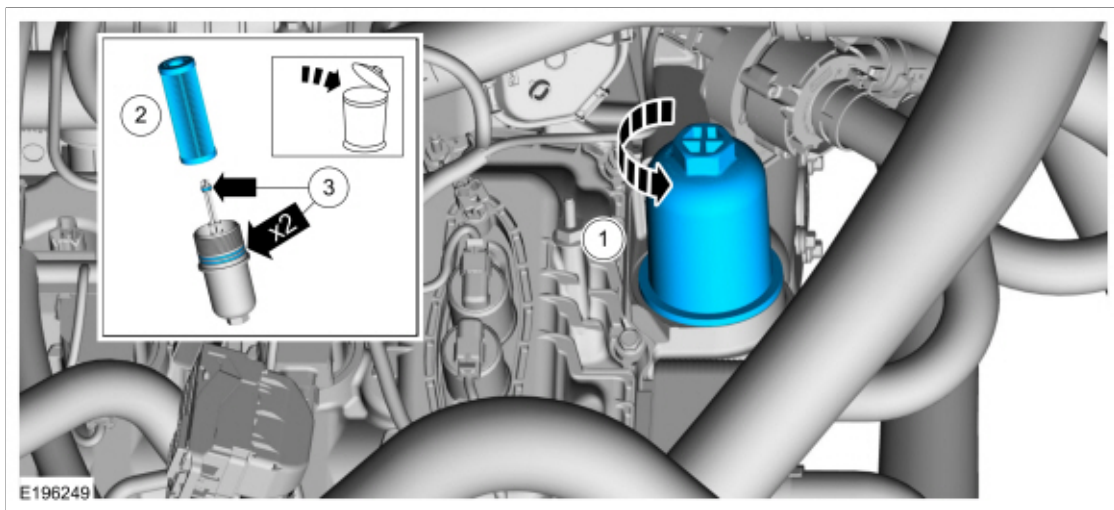

3. **NOTE:** The drain plug should be removed and installed by hand, do not use tools.
 1. Turn the oil drain plug by hand counterclockwise 120 degrees.
Use the General Equipment: Oil Drain Equipment
 2. Pull the oil drain plug out of the oil pan.
 3. After the oil has drained, push the oil drain plug into the oil pan.
 4. **NOTICE:** Overtightening will damage the oil drain plug and possibly the oil pan.

Turn the oil drain plug by hand clockwise 120 degrees.

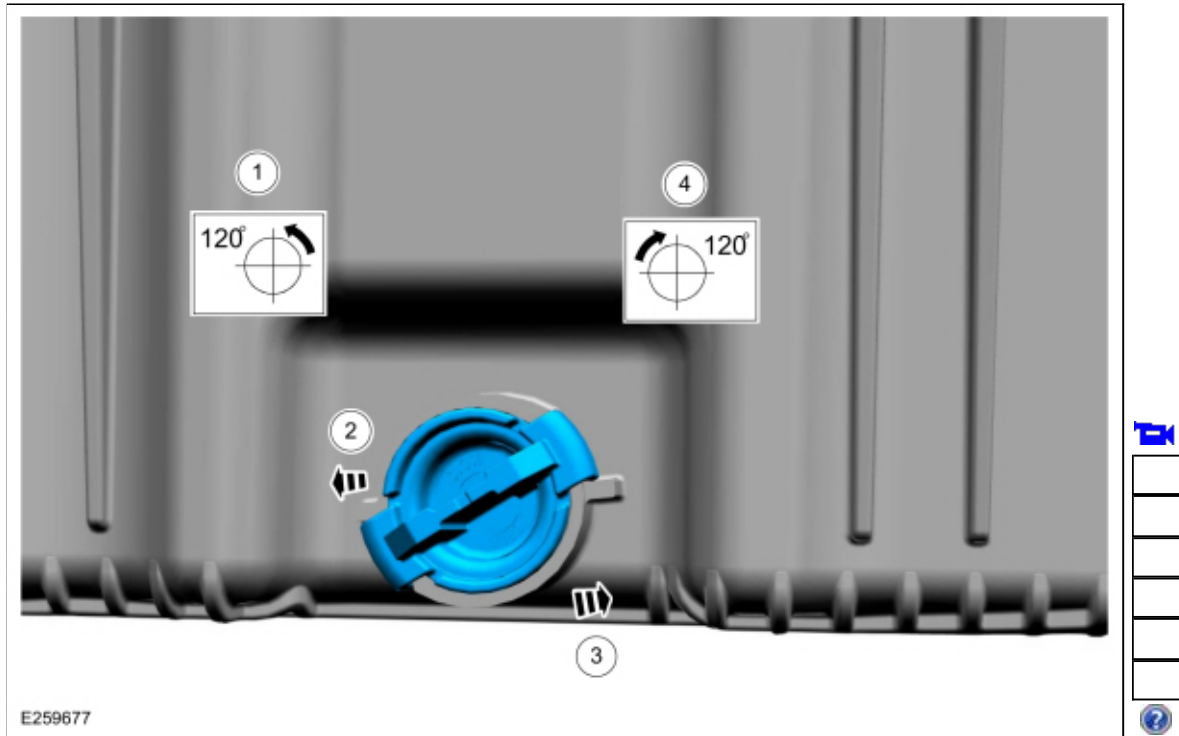

Filling

1. **NOTE:** If the filter housing stem is damaged or missing the oil will flow through the reservoir drain port and a **loss of engine oil pressure will occur.**

Inspect the oil filter housing and stem for damage including cracks or separation of the stem from the housing. If damaged, a new oil filter housing assembly must be installed.

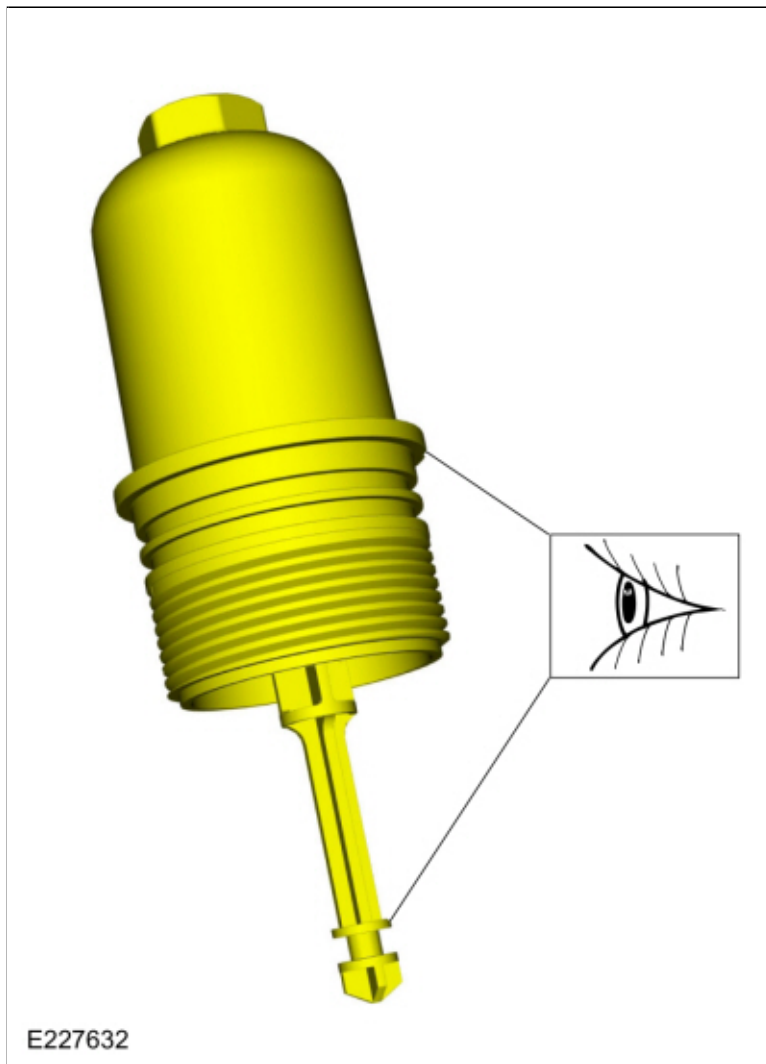

2.

- **NOTE:** Failure to install new oil filter housing-to-engine front cover seals may result in oil leakage.

Install new oil filter housing-to-engine front cover seals and lubricate with clean engine oil.

- **NOTE:** Failure to install a new oil filter housing stem-to-oil reservoir drain port seal will result with the oil flowing through the reservoir drain port and a **loss** of engine oil pressure.

Install a new oil filter housing stem-to-oil reservoir drain port seal and lubricate with clean engine oil.

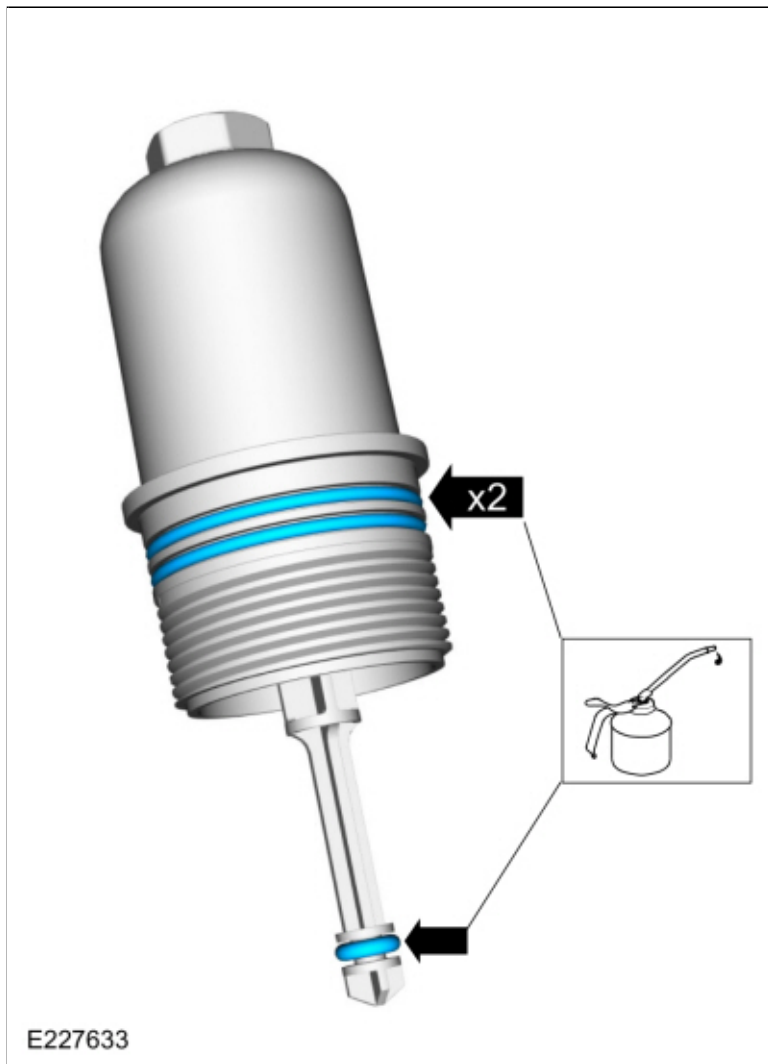

- 3.
 - 1. Install a new oil filter element.
 - 2. Install the oil filter housing.
Torque: 18 lb.ft (24 Nm)

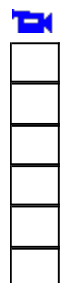

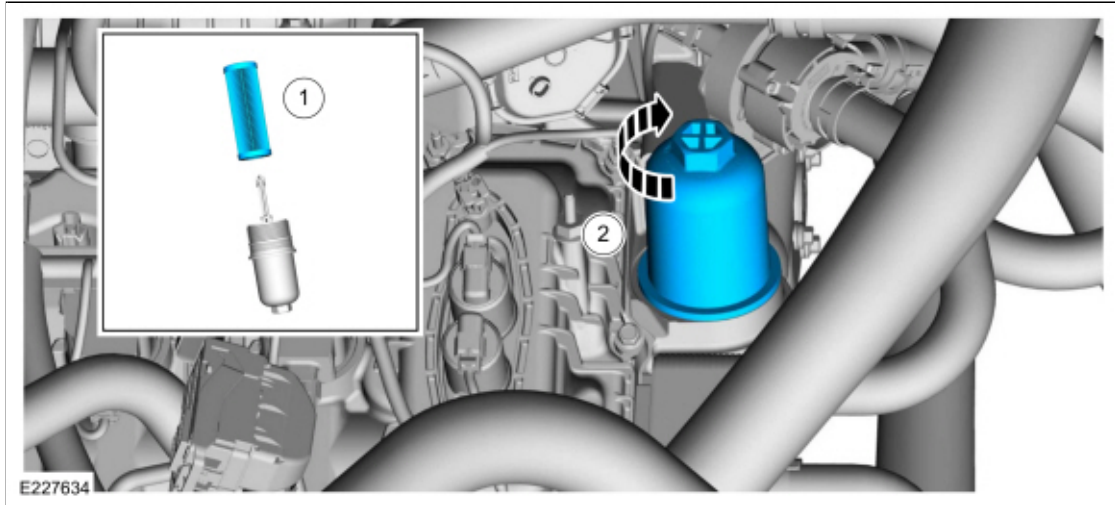

- 4. Fill the engine with clean engine oil.
Refer to: [Specifications](#) (303-01A Engine - 2.7L EcoBoost (238kW/324PS), Specifications).

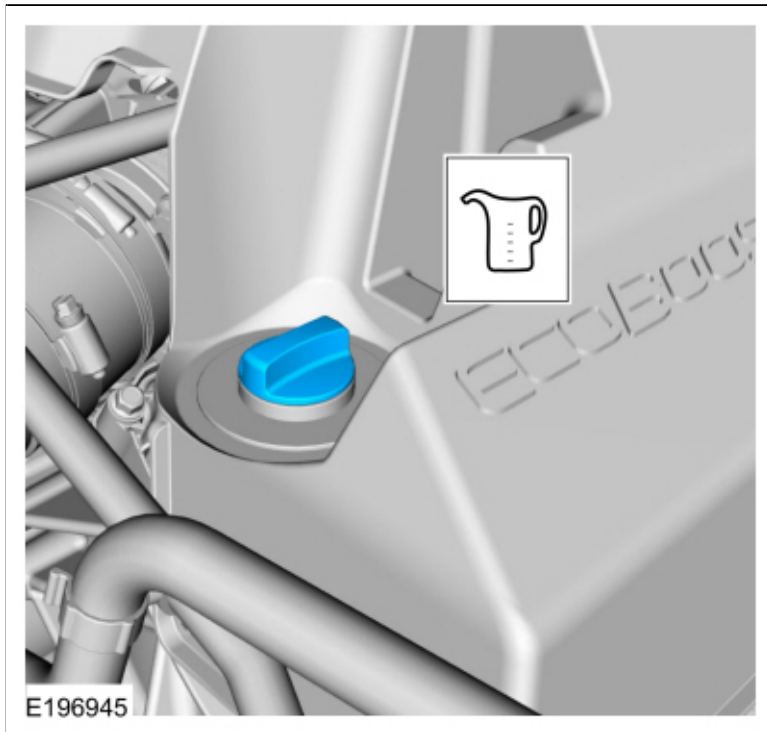

Copyright © 2019 Ford Motor Company

