

General Service Bulletin (GSB):	12V Battery Charging and Testing Quick Reference Guide
GSB Overview:	Information on 12V battery types, proper charging & testing procedures along with proper 12V battery maintenance and storage
NOTE: This information is not intended to replace or supersede any warranty, parts and service policy, Work Shop Manual (WSM) procedures or technical training or wiring diagram information.	

This GSB includes information on the following topics:

- **Battery Performance Measurements**
- **Types of Batteries**
- **Battery Charging and Testing Procedures**
- **Energy and Battery Management System (BMS) Operation**
- **Battery Handling and Long Term Storage**
- **Battery Charging During Pre-Delivery Inspection (PDI)**

12 V Battery Charging & Testing Quick Reference Guide

Battery Performance Measurements

- **State of Charge (SOC) – percentage (%)**
 - The amount of electrical energy stored in a battery at a given time expressed as a percentage of the energy when fully charged and dependent on the rate of discharge.
- **Open Circuit Voltage (OCV) – volts (v)**
 - The voltage of a battery when it is not delivering or receiving power.
- **Cold Cranking Amps (CCA) – amperes (a)**
 - The CCA rating is the number of amps that can be removed from a new fully charged battery at 0 deg F for 30 seconds while maintaining a voltage of at least 7.2v.
- **Reserve Capacity (RC) – minutes (min)**
 - The battery's ability to deliver a small amount of amperage to power a vehicle and its accessories with an inoperative alternator. The number of minutes a 12v battery at a temperature of 80 deg F can be discharged at 25 amps until it reaches a voltage of 10.5v.

SOC	0%	10%	20%	30%	40%	50%	60%	70%	80%	90%	100%
Voltage	11.75	11.87	11.98	12.09	12.21	12.32	12.44	12.55	12.66	12.78	12.89
Measured at 25 deg C									75% SOC=12.60v		

Above chart is for reference only, battery voltage to SOC percentage could vary depending on battery type and temperature. Also, any surface charge must be removed (blower motor on high & headlights on for 1 minute) before an accurate voltage can be measured.

12V Battery Charging & Testing Quick Reference Guide

Types of Batteries

- Standard Flooded Lead Acid (FLA) Battery Construction

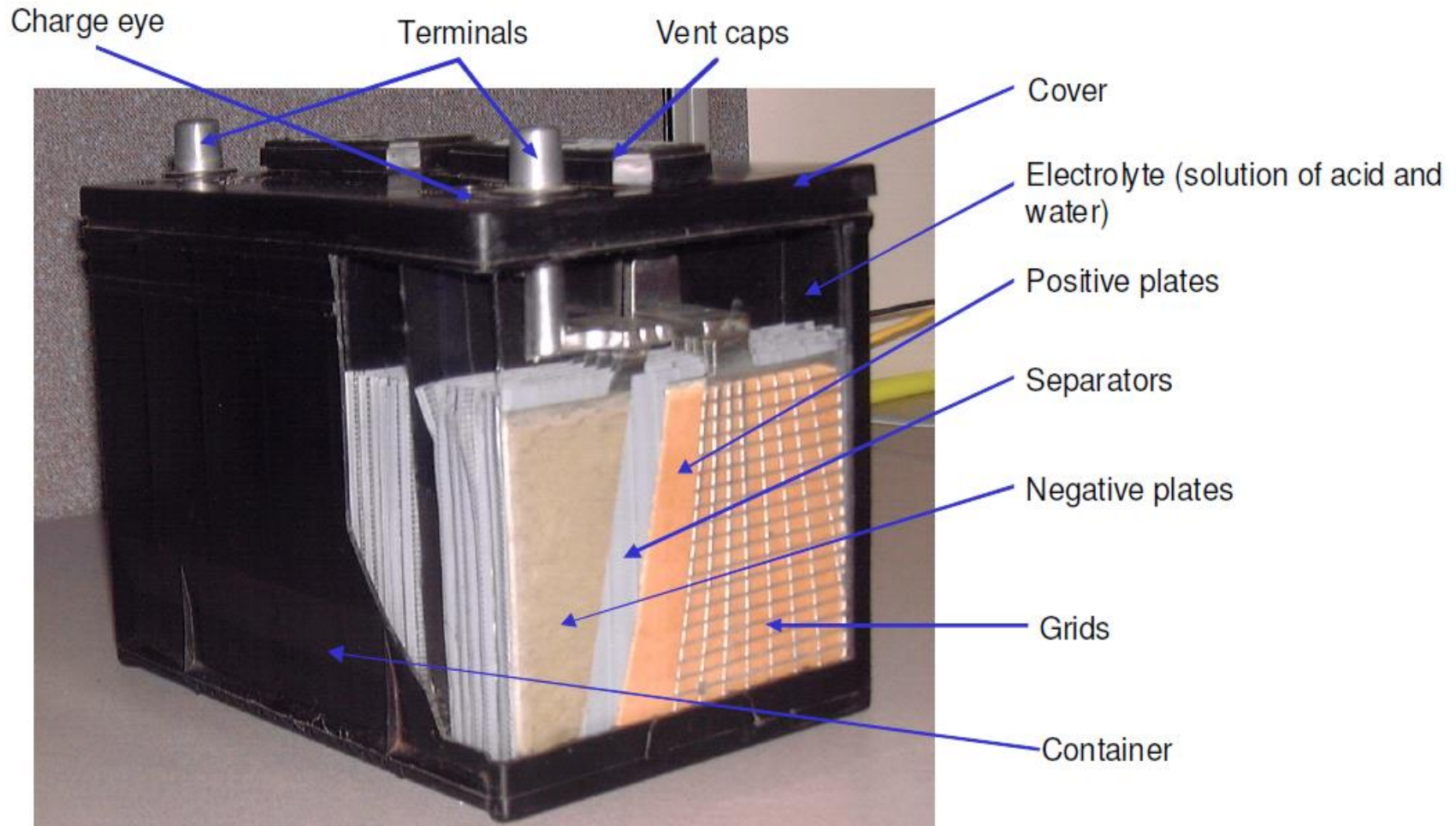

12V Battery Charging & Testing Quick Reference Guide

Types of Batteries

- Absorbent Glass Mat (AGM) Lead Acid Battery Construction

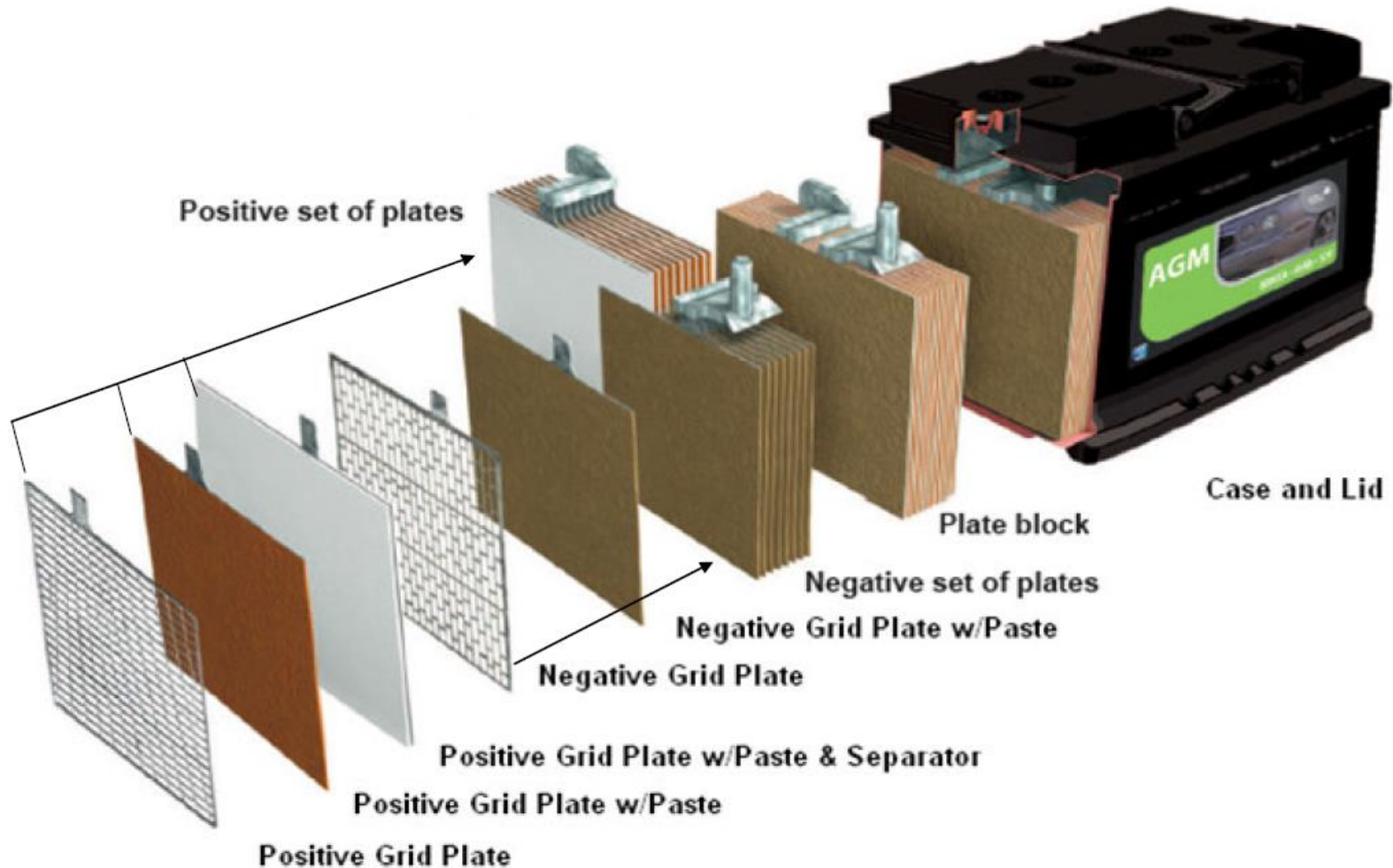

12V Battery Charging & Testing Quick Reference Guide

Types of Batteries

- Absorbent Glass Mat (AGM) Lead Acid Battery Identification
 - **AGM BATTERIES WILL HAVE THE RED AGM TECHNOLOGY LOGO ON THE TOP LABEL OF THE BATTERY AS WELL AS THE PREFIX BAGM IN THE PART NUMBER**



12V Battery Charging & Testing Quick Reference Guide

Types of Batteries

- Construction Differences between AGM and FLA Batteries
 - No electrolyte above the plates in AGM batteries, it is absorbed in the glass mat between the plates
 - There is no battery eye in an AGM battery
 - AGM batteries have pressure relief valves in the filling ports to release gasses when needed
- Operational Differences Between AGM and FLA Batteries
 - FLA batteries are always emitting gasses which can be explosive, AGM batteries will vent gasses only when there is a build up of pressure
 - FLA batteries lose hydrogen and oxygen (water) from the electrolyte due to off gassing, AGM batteries minimize the production of hydrogen and reuse the oxygen to reduce water loss
 - FLA batteries can be charged by either constant potential or constant / tapering current, AGM batteries should be charged by temperature compensated constant potential chargers with an AGM setting
 - **Note:** Use of constant current chargers on AGM batteries will over charge them causing water loss and eventually battery failure

12V Battery Charging & Testing Quick Reference Guide

Battery Charging and Testing Procedure

- **Battery Charging: AGM & FLA**
- Batteries are electrochemical energy storage devices, temperature, depth of discharge and how long a battery has been discharged will impact how well a battery charges and the accuracy of the test result.
- A cold battery is resistant to charging. A battery's surface temperature will not accurately reflect its core temperature. Cold batteries should be allowed to warm to at least 5°C (41°F) before charging. This may require four to eight hours at room temperature.
- As a battery discharges, the acid is converted to water. If a frozen battery is suspected, inspect the case for cracks or bulging and replace the battery if this is evident. Do not charge a frozen battery.
- Batteries that discharge slowly and stay discharged for a long period of time, will undergo chemical changes that cause a buildup of lead sulfate in both FLA and AGM batteries and acid stratification in FLA batteries. These conditions also impact how a battery charges and tests. Batteries that have been discharged for periods greater than 60 days may have permanent damage and/or shortened life.

12V Battery Charging & Testing Quick Reference Guide

Battery Charging and Testing Procedure

• Battery Charging: AGM & FLA(continued)

- Both the older GR1-190 and newer GRX-3590 are classified as battery tester/chargers and must be used for warranty. Both units have a Diagnostic/Charge mode and Manual Charge mode.
- In the Diagnostic/Charge mode the tool will test and charge the battery, determine if the battery is good or bad and if good, will go into top off mode.
- In Manual Charge mode, the operator will specify the charge parameters.
- In addition, the GRX-3590 has a Pre Delivery Inspection (PDI) charge mode. With the GRX-3590 PDI Charge mode, the tool will charge for 20 minutes before entering top off mode.
- The GR1-190, GRX-3590 and other combination Battery Chargers have user selectable settings for both FLA and AGM batteries that safely control both the charging currents and voltages (see page 9). Refer to the Rotunda Tool and Equipment catalog for battery charger options.
- If a generic shop charger is used, charging between 14.5 and 16.0 volts will fully charge a FLA battery.

NOTE: AGM batteries must be charged by a charger with a dedicated AGM mode with a maximum permissible voltage of 14.6 volt at room temperature. (see page 9)

- When testing a battery with the GR1-190, GRX-3590 and most other intelligent battery testers, the most accurate results are obtained by connecting the tester cables directly to the cable ends on the battery posts. When testing in a vehicle that limits you to attach to the battery wire harness connectors and or a battery chassis ground, the test result will be suspect. Retesting to the battery post when possible is recommended.

12V Battery Charging & Testing Quick Reference Guide

Energy and Battery Management Systems (BMS)



- AGM and FLA Combination Battery Chargers
- FLA Batteries use this mode
- AGM Batteries use this mode
- Other Combination Battery Chargers similar, refer to the Rotunda Tool and Equipment catalog

12V Battery Charging & Testing Quick Reference Guide

Energy and Battery Management Systems (BMS)

- **Basic Battery Management System Operation**
 - The Battery Management System is part of the overall Vehicle Energy Management Strategy
 - The systems monitors battery voltage, current, and temperature to calculate battery state variables
 - Battery state variables and battery parameters are inputs to the BMS software in the Body Control Module (BCM)
 - This allows the system to either reduce fuel consumption when the system is optimal or protect the battery from deep discharging that will limit the life of the battery

12V Battery Charging & Testing Quick Reference Guide

Energy and Battery Management Systems (BMS)

- **Elements of the Energy and Battery Management System**
 - **Smart Regen Charging (SRC):**
 - SRC will conserve fuel when the battery SOC is in the 80% range by lowering the charging system voltage which reduces alternator torque on the engine
 - **Load Shedding:**
 - Load Shedding will happen when the battery SOC and system voltage fall below a set threshold
 - The BMS software will take action to reduce or eliminate this consumption when load shedding is triggered
 - This protects the battery from deep discharges that can reduce battery life
 - **Stop Start Vehicle Function Monitoring:**
 - On Stop-Start vehicles the battery condition and functionality is monitored to verify the battery has the capability to restart the engine
 - The Battery Monitor or Intelligent Battery sensor provides detailed information to the BMS software in the BCM
 - The system will inhibit the Stop-Start function if it is determined that the battery will not be able to restart the vehicle and will convert back when proper SOC and battery voltage is achieved

12V Battery Charging & Testing Quick Reference Guide

Energy and Battery Management Systems (BMS)

• Elements of the Energy and Battery Management System (cont.)

– Battery Charging or Jump Starting:

- To charge or jump start the vehicle, connect the positive cable to the battery positive post and then connect the negative cable to a vehicle ground and **not** the battery negative post
- Connecting directly to the negative battery post can have an adverse effect on the Electrical Energy Management system
- If the battery is jump started or charged, the BCM **must** recalibrate the battery state of charge
- It takes 8 hours in sleep mode, with the vehicle undisturbed, no doors opened or keyless entry buttons pressed, and the total vehicle current draw less than 300mA, to calibrate the battery state of charge to a high accuracy

– Battery Replacement

- If the vehicle battery is replaced, it is very important to perform the BMS Reset using a diagnostic scan tool.
- If the battery monitoring system reset is not carried out, it holds the old battery parameters and time in service counter in memory and it tells the system the battery is in an aged state and may limit the Electrical Energy Management system functions
- **NOTE: DO NOT reset the battery monitoring system using the diagnostic scan tool if the battery is not being replaced. This reset is reserved for new battery installation. Resetting the battery monitoring system will clear the learned battery data, the battery time in service, and will affect the aging algorithm parameters, which have been learned since the installation of the battery.**

12V Battery Charging & Testing Quick Reference Guide

Energy and Battery Management Systems (BMS)

- Battery Sensor Type 1: Hall Effect Battery Current Sensor
 - Used on for SRC and Load Shedding functions, not for Stop-Start vehicles
 - This sensor slips over the battery ground cables (both engine and body grounds) and measures only the current in (charge) and out (discharge)
 - Battery voltage is measured remotely in the BCM and battery temperature is inferred from other vehicle sensors

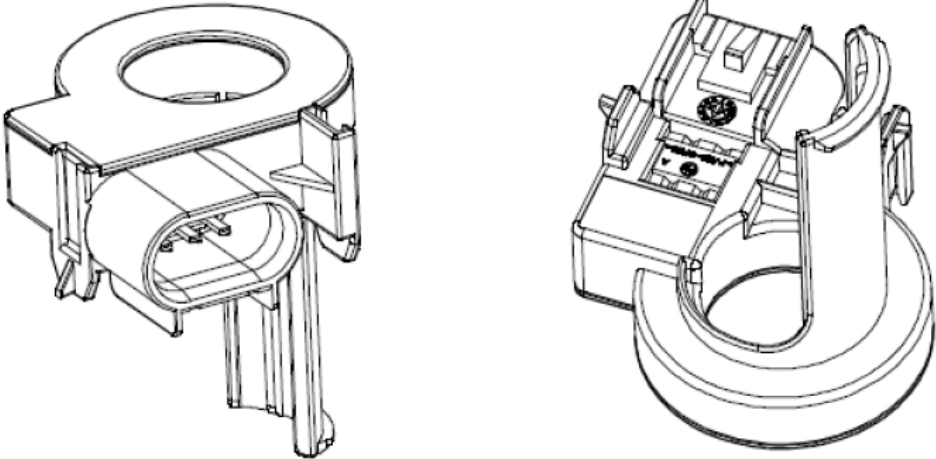
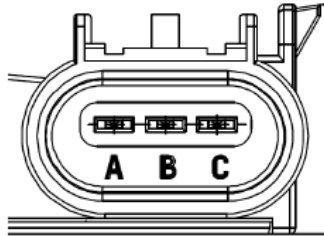
Sensor	Details
<p data-bbox="131 679 743 722">Hall Effect Battery Current Sensor:</p> 	<p data-bbox="1238 679 1483 715">3 Pin Connector:</p> <ul data-bbox="1290 722 1586 836" style="list-style-type: none">Pin A: 5VPin B: GroundPin C: PWM output  <p data-bbox="1290 1193 1740 1265">Measurement Range: -100A to +100A</p>

12V Battery Charging & Testing Quick Reference Guide

Energy and Battery Management Systems (BMS)

- Battery Sensor Type 2: *Battery Monitor Sensor*
 - Used on vehicles with Stop-Start Functionality
 - This sensor mounts directly to the battery negative terminal and is powered from the battery positive terminal
 - It measures current, voltage, and temperature of the battery and has a microprocessor that is capable of highly accurate calculations of battery state variables that are sent to the BCM via LIN communication line

Battery Monitor Sensor with Ground Cable Stud:

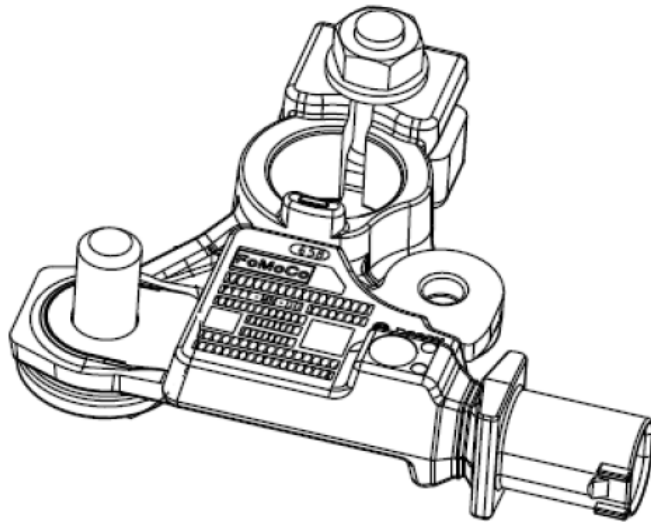

2 Pin Connector

Pin 1: LIN output to BCM
Pin 2: Vbatt

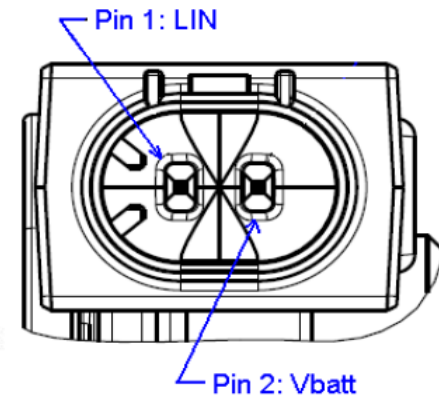

Measurement Range:

Current: -1200A to +1200A

Voltage: 0V to 16V

Temperature: -40 to +105C

12V Battery Charging & Testing Quick Reference Guide

Battery Handling and Long Term Storage

• Vehicles in Storage and/or Limited Operation

- Batteries will discharge while the vehicle is in storage due to normal current draw loads
- Vehicles have several modules in their electrical system that will draw small amounts of current (20-30 milliamps 0.02-0.03 amps) the more discharged a battery gets the more susceptible it is to permanent damage (more likely to happen in temperatures below 32 deg. F / 0 deg. C)
- The charging system is not capable of bringing a deeply discharged battery back to near full charge in a short time, such as idling for 15 minutes or short drive cycles
- Vehicles stored for extended periods of time may need to use an auxiliary battery maintainer/charge expressly designed to do this
- Battery Saver/Transport Mode is used to reduce the vehicle's electrical system battery draw by turning off features that are not essential and is intended to stay enabled as long as possible before vehicle delivery
 - Refer to “Storage of New Vehicles – Storage Policy” in Section 2 of the Warranty and Policy Manual in “Carrier Drop-Off & New Car Delivery”
- Battery SOC drops about 10% a month in Transport Mode and more than 20% in Customer Mode
- NOTE: Vehicles cannot be put back into Transport Mode once exited

12V Battery Charging & Testing Quick Reference Guide

Battery Charging During Pre-Delivery Inspection (PDI)

- Using Midtronics GRX-3590 Diagnostic Battery Charger
 - Use the PDI setting (see below)
 - From the “Main Menu” pick “Charging” then “PDI”. The charger will automatically charge at the correct voltage for 20 minutes and then give you the option to end or extend the charge.

NOTE: DO NOT USE THE DIAGNOSTIC MODE WHILE CHARGING THE BATTERY WHEN COMPLETING A PDI. USE MANUAL CHARGE OR PDI MODE



Using a Standard AGM/FLA Battery Charger

- For FLA Batteries charging between 14.5 and 16.0 volts for 20 to 40 minutes while performing PDI is recommended
- For AGM Batteries charging at no more than 14.5 volts for 20 to 40 minutes while performing PDI is recommended