

303-03B Engine Cooling - 3.5L Duratec (209kW/284PS)
Removal and Installation

2015 F-150
Procedure revision date: 08/4/2017

Thermostat Housing

Special Tool(s) / General Equipment

Hose Clamp Remover/Installer

Materials

Name	Specification
Motorcraft® Orange Concentrated Antifreeze/Coolant VC-3-B	WSS-M97B44-D

Removal

NOTE: Removal steps in this procedure may contain installation details.

1. Drain the cooling system.
Refer to: [Cooling System Draining, Vacuum Filling and Bleeding](#) (303-03B Engine Cooling - 3.5L Duratec (209kW/284PS), Removal and Installation).
2. Remove the air cleaner outlet pipe.
Refer to: [Air Cleaner Outlet Pipe](#) (303-12B Intake Air Distribution and Filtering - 3.5L Duratec (209kW/284PS), Removal and Installation).
3. Remove the bolts and position the degas bottle aside.
Torque: 62 lb.in (7 Nm)



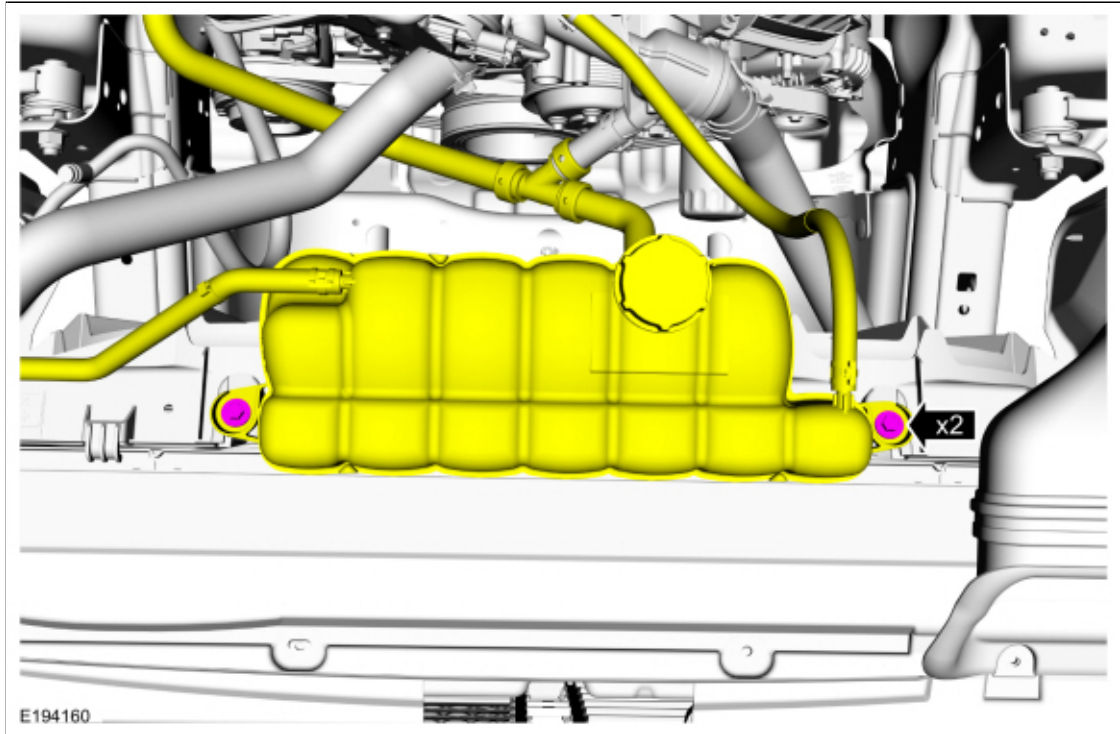

4. **NOTICE: Cover the accessory drive belts to prevent coolant contamination of the belts.**

Completely cover the accessory drive belts with waterproof plastic.

5.

- Disconnect the coolant hoses.
Use the General Equipment: Hose Clamp Remover/Installer
- If equipped, disconnect the block heater electrical connector and detach the wiring harness retainer.

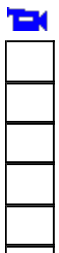

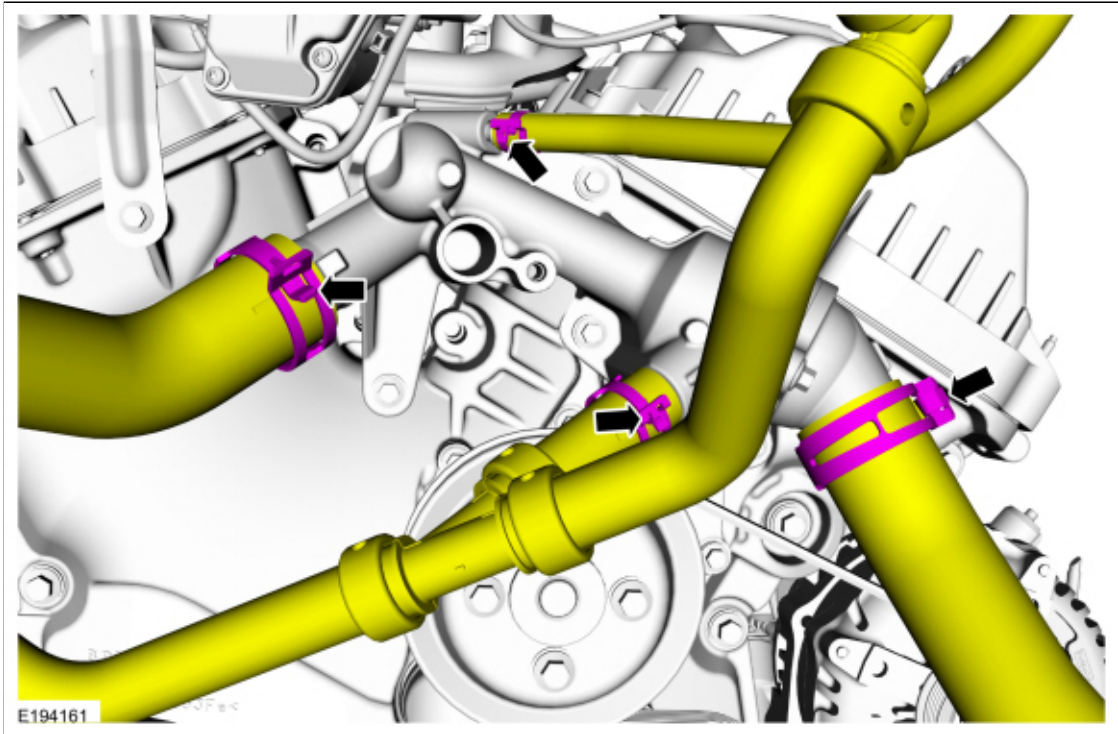

6. Remove the bolts and the thermostat housing.

Torque:

Stage 1: 71 lb.in (8 Nm)

Stage 2: 45°

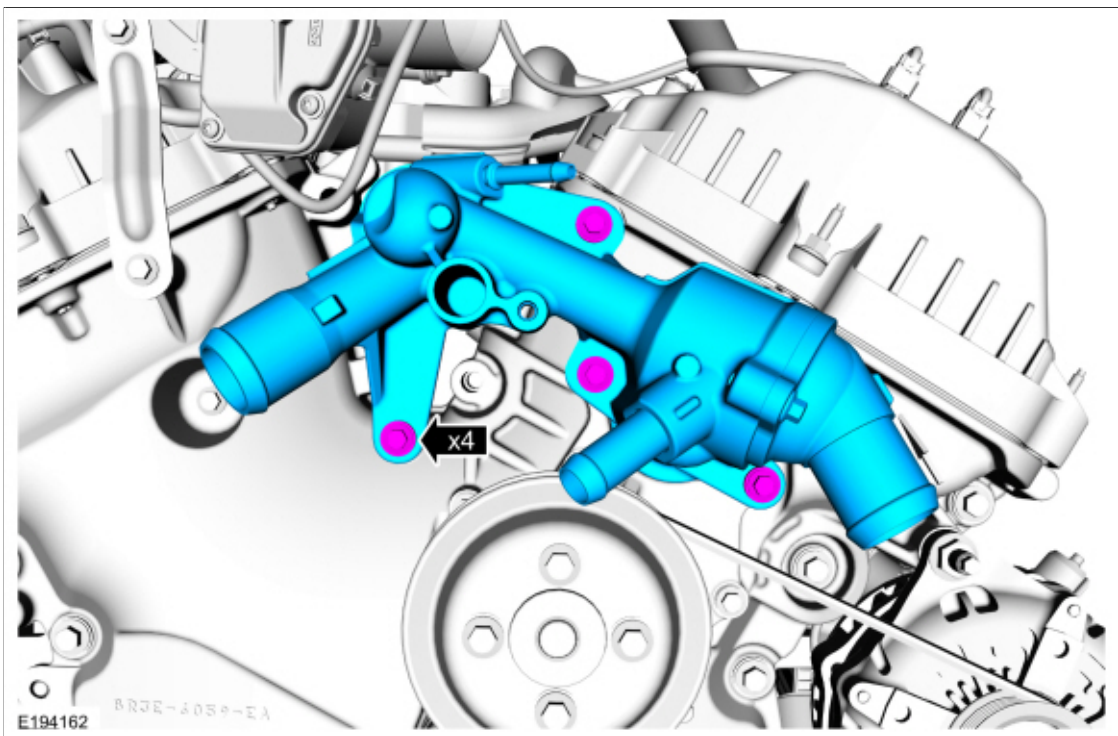

7. Remove and discard the O-ring seal.

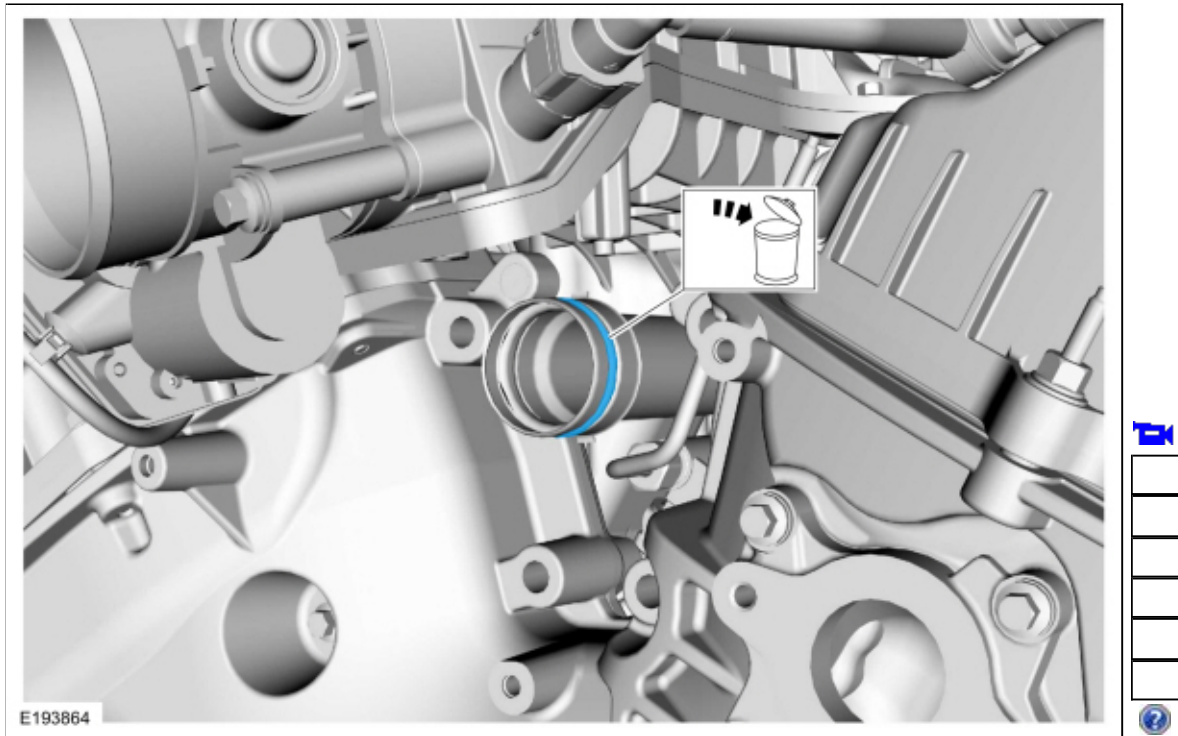

8. Inspect the O-ring seal and replace if necessary.

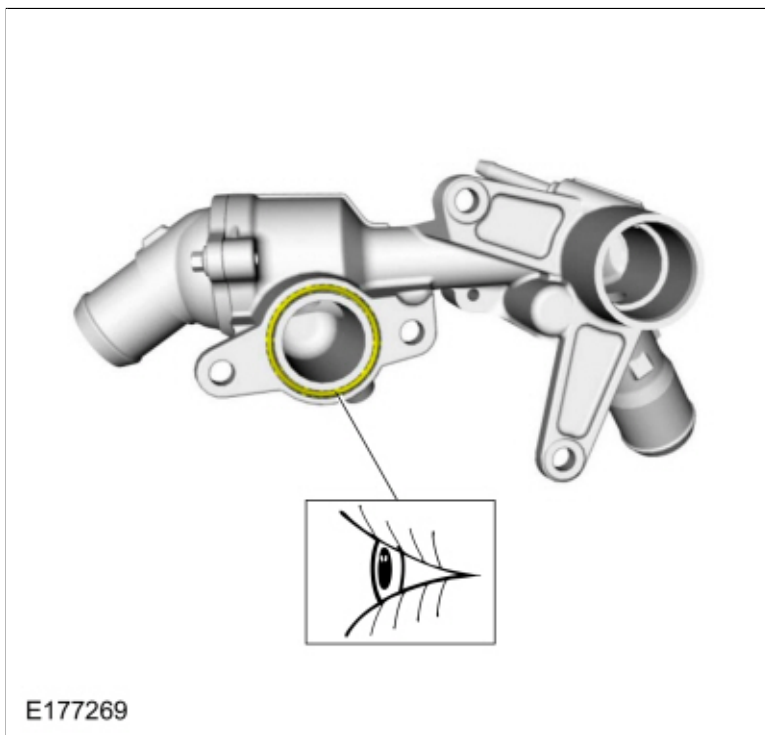

Installation

1. Install a new O-ring seal and lubricate it with clean engine coolant.
Material: Motorcraft® Orange Concentrated Antifreeze/Coolant / VC-3-B (WSS-M97B44-D)

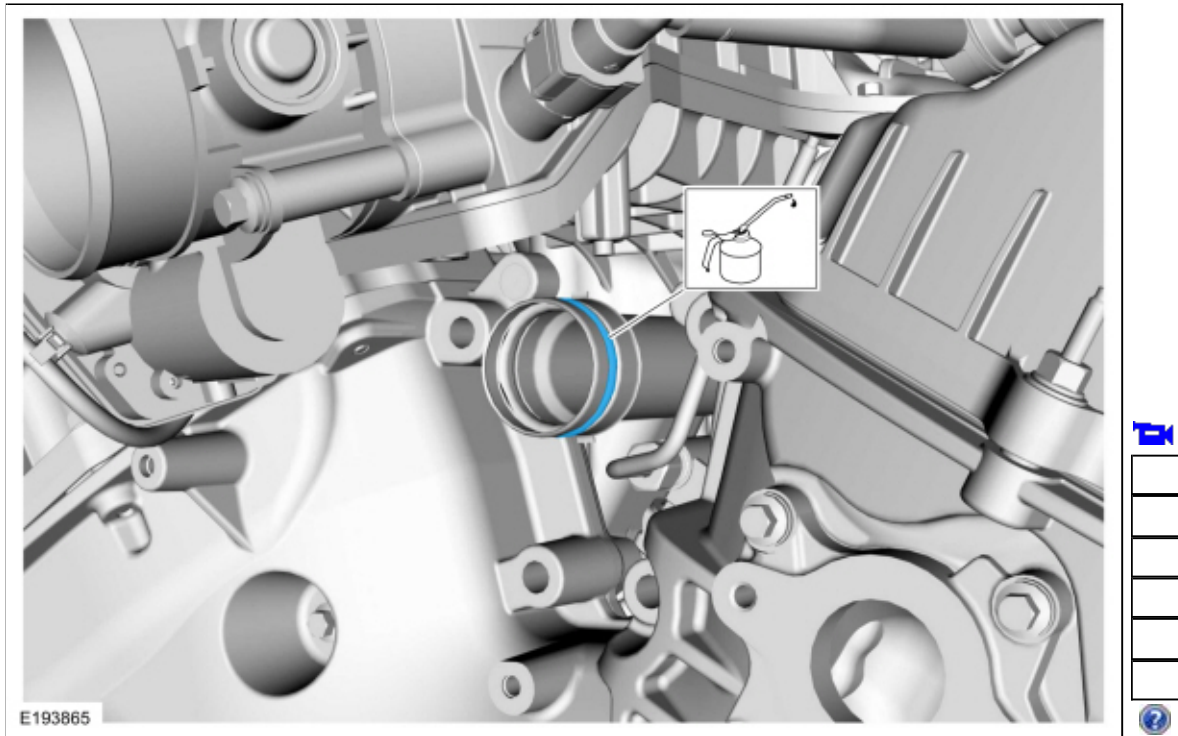

2. To install, reverse the removal procedure.
3. Fill and bleed the cooling system.
Refer to: [Cooling System Draining, Vacuum Filling and Bleeding](#) (303-03B Engine Cooling - 3.5L Duratec (209kW/284PS), Removal and Installation).

Copyright © 2019 Ford Motor Company

