

2015-16 F150 SCrew OEM Power Fold Mirror Retrofit

Trailer Tow Mirror Part #s (17682 = RH/17683 = LH) and Features

- XL (100A) Trailer Tow Mirror -- **FL3Z-17682-AB and FL3Z-17683-AB** - Manual mirrors w/black textured skull caps includes: manual fold & telescope, without power adjust, heat, turn signals, marker lights, spot lamps, LED security approach lamps, BLIS, memory, auto dimming (driver's side only) or side camera
- XL (101A)/XLT (300A/301A/302A) Trailer Tow Mirror -- **FL3Z-17682-AC and FL3Z-17683-AC** - Power mirrors w/black textured skull caps includes: power adjust, heat, turn signals, marker lights, with manual fold & telescope, spot lamps, LED security approach lamps, without BLIS, memory, auto dimming (driver's side only) or side camera
- Lariat (500A) Trailer Tow Mirror -- **FL3Z-17682-AD and FL3Z-17683-AD** Power mirrors w/black textured skull caps includes: power adjust, heat, turn signals, marker lights, power fold & telescope, memory, auto dimming (driver's side only), spot lamps, LED security approach lamps, without BLIS or side camera
- Lariat (500A) Trailer Tow Mirror -- **FL3Z-17682-AE and FL3Z-17683-AE** Power mirrors w/chrome skull caps includes: power adjust, heat, turn signals, marker lights, power fold & telescope, memory, auto dimming (driver's side only), spot lamps, LED security approach lamps, without BLIS or side camera
- Lariat (501A & 502A wo/Technology Pkg.) Trailer Tow Mirror -- **FL3Z-17682-AF and FL3Z-17683-AF** Power mirrors w/black textured skull caps includes: power adjust, heat, turn signals, marker lights, power fold & telescope, memory, auto dimming (driver's side only), BLIS, spot lamps, LED security approach lamps, without side camera
- Lariat (501A & 502A wo/Technology Pkg.) Trailer Tow Mirror -- **FL3Z-17682-AG and FL3Z-17683-AG** Power mirrors w/chrome skull caps includes: power adjust, heat, turn signals, marker lights, power fold & telescope, memory, auto dimming (driver's side only), BLIS, spot lamps, LED security approach lamps, without side camera
- Lariat (502A – w/Technology Pkg.) Trailer Tow Mirror -- **FL3Z-17682-AH and FL3Z-17683-AH** Power mirrors w/black textured skull caps includes: power adjust, heat, turn signals, marker lights, power fold & telescope, memory, auto dimming (driver's side only), spot lamps, LED security approach lamps, BLIS and side camera
- Lariat (502A w/Technology Pkg.) Trailer Tow Mirror -- **FL3Z-17682-AJ and FL3Z-17683-AJ** Power mirrors w/chrome skull caps includes: power adjust, heat, turn signals, marker lights, power fold & telescope, memory, auto dimming (driver's side only), spot lamps, LED security approach lamps, BLIS and side camera

Note: Trailer Tow Mirrors are not available with PTM (Paint to Match) skull caps. Black textured or chrome skull caps must be removed, sanded and painted to match body color.

Non-Trailer Tow Mirror Part #s (17682 = RH/17683 = LH) and Features

- Lariat (500A) Non-Trailer Tow Mirror -- **FL3Z-17682-GDPTM and FL3Z-17683-GEPTM** Power mirrors w/PTM (paint to match) skull caps includes: power adjust, heat, turn signals, power fold, memory, auto dimming (driver's side only), LED security approach lamps, without spot lamps, BLIS or side camera
- Lariat (500A) Non-Trailer Tow Mirror -- **FL3Z-17682-LB and FL3Z-17683-LC** Power mirrors w/chrome skull caps includes: power adjust, heat, turn signals, power fold, memory, auto dimming (driver's side only), LED security approach lamps, spot lamps, without BLIS or side camera
- Lariat (500A) Non-Trailer Tow Mirror -- **FL3Z-17682-KDPTM and FL3Z-17683-KDPTM** Power mirrors w/PTM (paint to match) skull caps includes: power adjust, heat, turn signals, power fold, memory, auto dimming (driver's side only), LED security approach lamps, spot lamps, without BLIS or side camera
- Lariat (501A & 502A wo/Technology Pkg.) Non-Trailer Tow Mirror -- **FL3Z-17682-RCPTM and FL3Z-17683-RDPTM** Power mirrors w/PTM (paint to match) skull caps includes: power adjust, heat, turn signals, power fold, memory, auto dimming (driver's side only), LED security approach lamps, BLIS, without spot lamps or side camera
- Lariat (501A & 502A wo/Technology Pkg.) Non-Trailer Tow Mirror -- **FL3Z-17682-JB and FL3Z-17683-JC** Power mirrors w/chrome skull caps includes: power adjust, heat, turn signals, power fold, memory, auto dimming (driver's side only), LED security approach lamps, BLIS, without spot lamps or side camera
- Lariat (501A & 502A wo/Technology Pkg.) Non-Trailer Tow Mirror -- **FL3Z-17682-MCPTM and FL3Z-17683-MDPTM** Power mirrors w/PTM (paint to match) skull caps includes: power adjust, heat, turn signals, power fold, memory, auto dimming (driver's side only), LED security approach lamps, spot lamps, BLIS, without side camera
- Lariat (501A & 502A wo/Technology Pkg.) Non-Trailer Tow Mirror -- **FL3Z-17682-NB and FL3Z-17683-NC** Power mirrors w/chrome skull caps includes: power adjust, heat, turn signals, power fold, memory, auto dimming (driver's side only), LED security approach lamps, spot lamps, BLIS, without side camera
- Lariat (502A w/Technology Pkg.) Non-Trailer Tow Mirror -- **FL3Z-17682-PB and FL3Z-17683-PC** Power mirrors w/chrome skull caps includes: power adjust, heat, turn signals, power fold, memory, auto dimming (driver's side only), LED security approach lamps, spot lamps, BLIS and side camera
- Lariat (502A w/Technology Pkg.) Non-Trailer Tow Mirror -- **FL3Z-17682-SCPTM and FL3Z-17683-SDPTM** Power mirrors w/PTM (paint to match) skull caps includes: power adjust, heat, turn signals,

power fold, memory, auto dimming (driver's side only), LED security approach lamps, spot lamps, BLIS and side camera

Note: Power Folding Non-Trailer Tow Mirrors are not available with black textured skull caps. PTM (Paint to Match) skull caps are shipped primed and must be painted to match body color.

Door Harness Part #s (14630 = RH/14631 = LH) and Features

- Lariat (500A, 501A & 502A wo/Technology Package) door harnesses w/22 pin mirror connector, **FL3Z-14630-E and FL3Z-14631-A** support power adjust, heat, turn signals, power fold & telescope, memory, auto dimming (driver's side only), spot lamps, LED security approach lamps and BLIS - Does **NOT** support Technology Pkg. w/side camera. Driver's side door harness requires modification (4 terminals must be repinned) of 8 pin connector (C541) to 4 pin connector (C505) for LH front door lock switch without memory. Connectors for exterior front door handle switch (C543 & C634) and interior front door handle ambient lighting (C573 & C649) won't be used.
- Lariat (502A w/Technology Package) door harnesses w/22 pin mirror connector, **FL3Z-14630-G and FL3Z-14631-J** support power adjust, heat, turn signals, power fold & telescope, memory, auto dimming (driver's side only), spot lamps, LED security approach lamps, BLIS and side camera. Driver's side door harness requires modification (4 terminals must be repinned) of 8 pin connector (C541) to 4 pin connector (C505) for LH front door lock switch without memory. Connectors for exterior front door handle switch (C543 & C634), interior front door handle ambient lighting (C573 & C649) and side camera (C5104 & C6104) won't be used.
- XLT door harnesses w/22 pin mirror connector, **FL3Z-14630-C and FL3Z-14631-F** support power adjust, heat, turn signals, auto-dimming, LED security approach lamps, spot lamps and BLIS - Does **NOT** support power fold & telescope, memory or Technology Pkg. w/side camera. **Note:** if vehicle currently has 22 pin door harnesses, the existing door harnesses can quickly/easily be modified to support the power fold (not power telescope, memory or Technology Pkg. w/side camera) function by simply adding (5) additional wires from each door module to the 22 pin mirror connector. You will need to purchase (20) DU2Z-14474-CA (WT-1002) wires. This will make (10) wire assemblies – (5) for each door. Wiring schematics below show the (5) wires that must be added to each door harness. **Failure to add the additional (3) wire assemblies to each door harness for Mirror Sense (Memory) will result in DTC C1B15:15 that cannot be cleared in each door module.**

Driver's Door Harness Modification

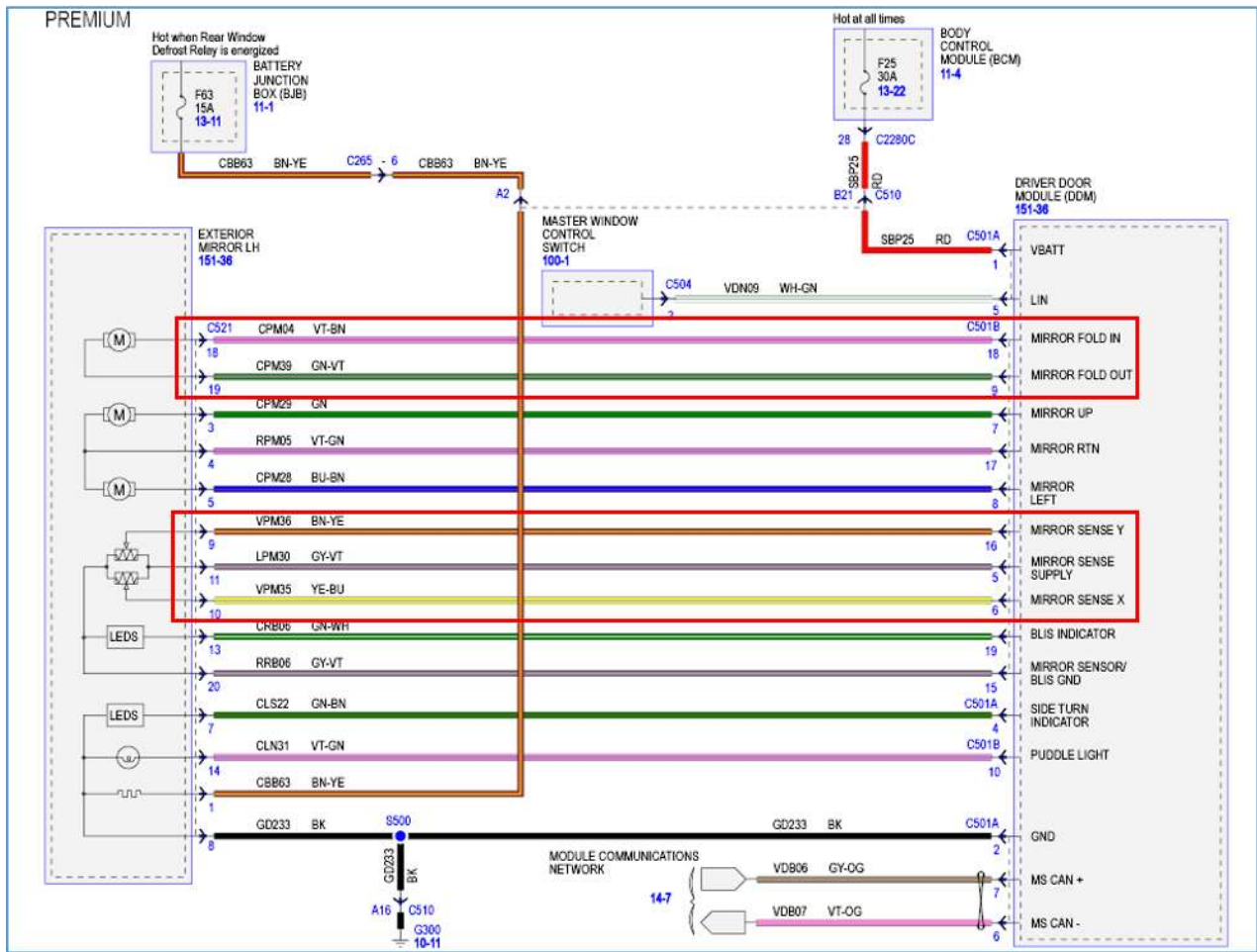

Passengers' Door Harness Modification

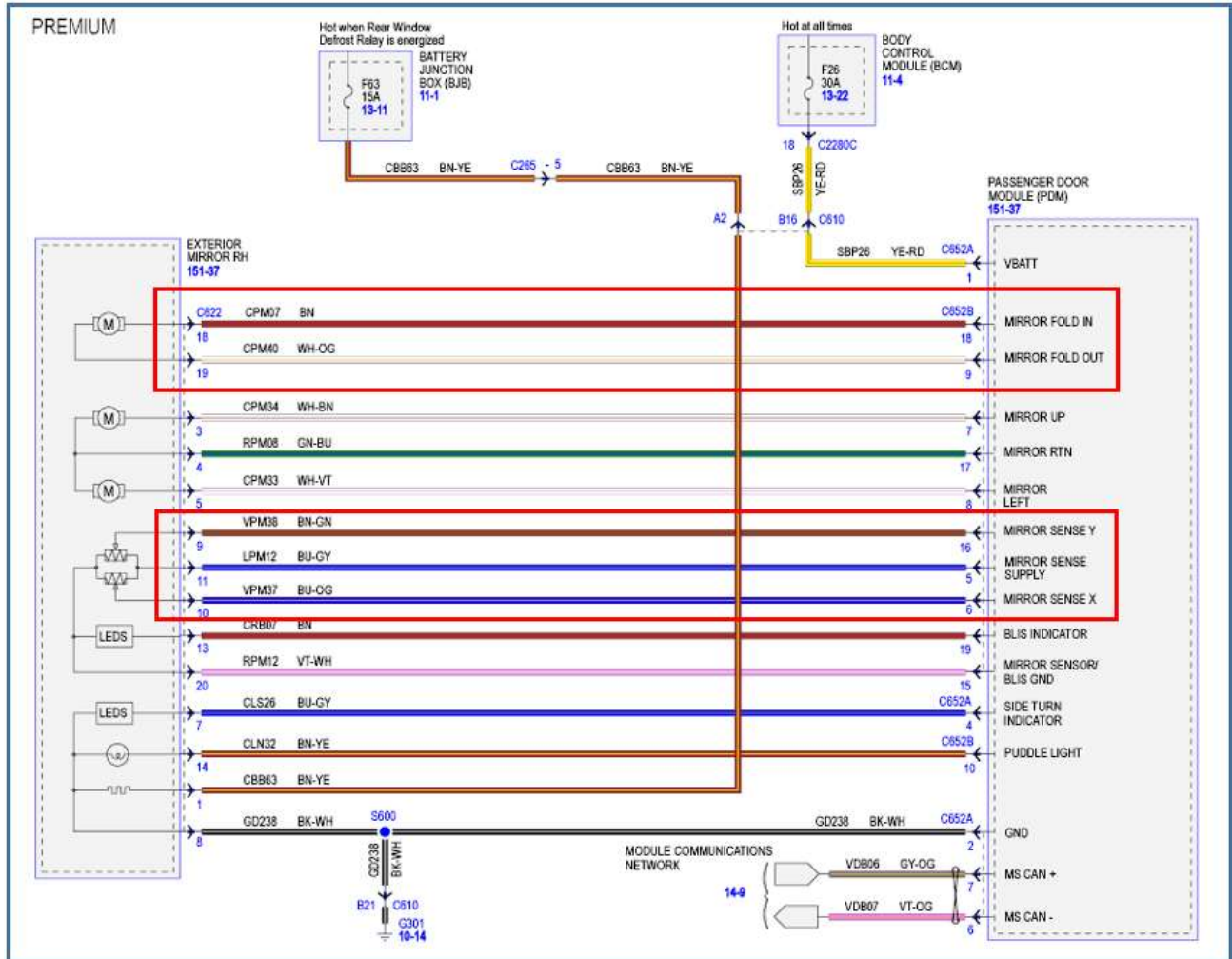

Door Modules

- With BLIS** **vehicles built on 10/20/14 thru 4/7/16** -- DG9Z-14B291-WP (Driver) FK7Z-14B291-C (Passenger) (**Required for Power Fold**)
- With BLIS** **vehicles built on 4/8/16 thru 1/12/17** -- DG9Z-14B291-WG (Driver) DG9Z-14B291-WR (Passenger) (**Required for Power Fold**)
- With BLIS** **vehicles built on or after 1/13/17** -- DG9Z-14B291-WP (Driver) DG9Z-14B291-WR (Passenger) (**Required for Power Fold**)

****Non-BLIS Door Modules do not support power fold. Door modules must be replaced with BLIS door modules**

Note: prior to any work being performed, see notes in the Door Module Programming section of this document

Mirror Switch

- Power fold only -- FL3Z-14529-CB (SW-7836)
- Power fold and telescope -- FL3Z-14529-BA (SW-7441)

Spot Lamps

- Switch -- FL3Z-13D730-EA
- Processor (module) -- FU5Z-13C788-A - Requires a \$50 core deposit
- LH Dash vent trim which holds spot lamp switch -- FL3Z-1504339-DB

OEM Terminals to add Trailer Tow Mirror Power Telescope circuit to 14A005 XLT dash harness

- DU2Z-14474-BA (WT-1001) Terminal – C265 Female Connector (RH Side of 14A005 Cab Harness – Engine Harness End)
- DU2Z-14474-CA (WT-1002) Terminal – C510 & C610 Female Connector (LH & RH side of 14A005 Cab Harness – Door Harness End)
- BU5T-14421-HA Terminal - C268 Male Connector (LH Side of 14A005 Cab Harness – Engine Harness End). **This terminal is NOT serviced through Ford Parts.** However this terminal can be salvaged from either of the 8 pin XLT door harnesses (C510 connector - pin A8 or A11, or C610 connector - pin A11 or A21). Suggest using 3U2Z-14A088-AB (WT-56814) 18-22 AWG terminal (splice kit) to connect salvaged terminals to additional wiring – see below.
- Belden (NAPA) 785105 20 AWG Green Primary Wire (Telescope Function)
- Belden (NAPA) 785109 20 AWG White Primary Wire (Retract Function)

In the wiring diagram below, the additional wires that must be added to the 14A005 dash harness for the power telescope circuit are highlighted in the red boxes.

TELESCOPING MIRRORS

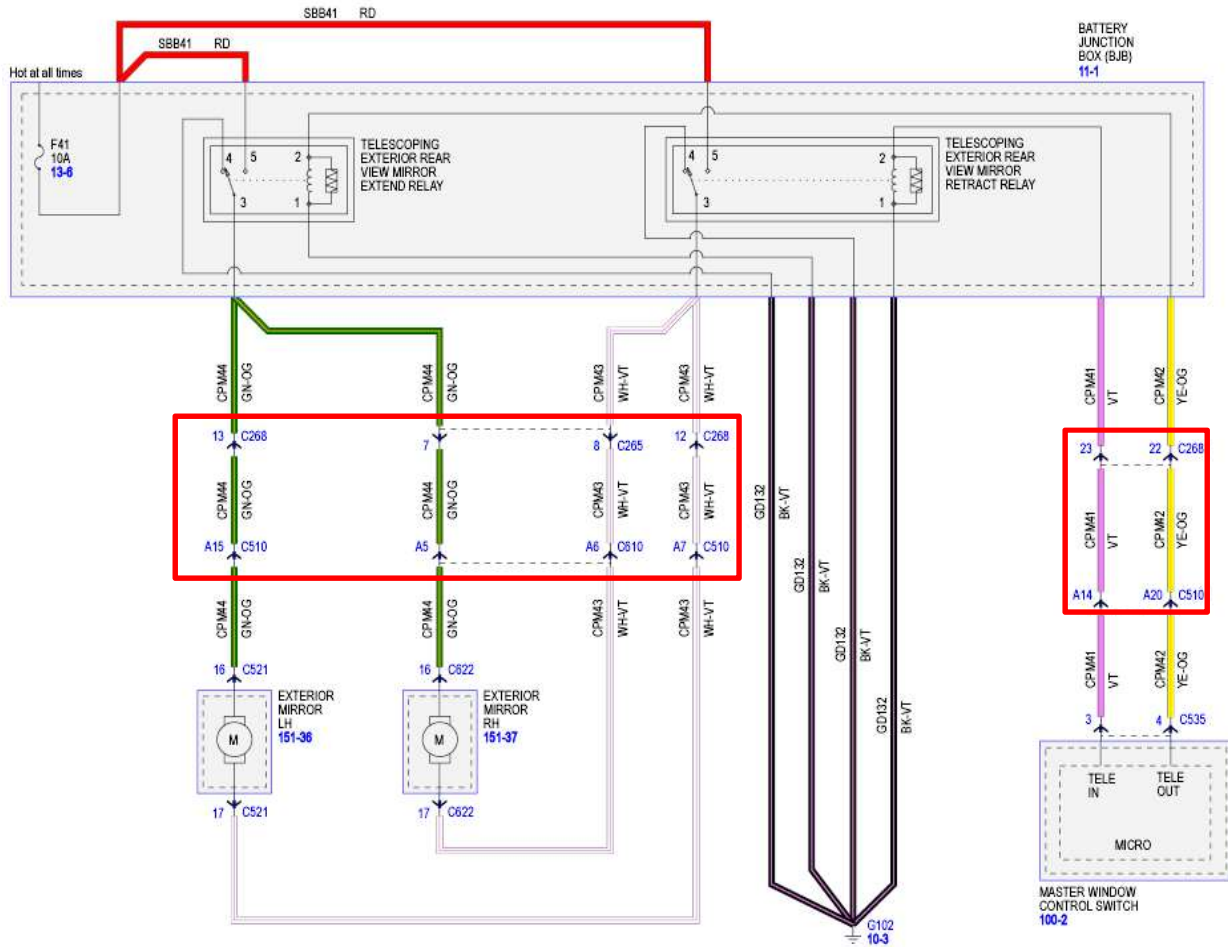

Door Module Programming

Note: if using FORScan to program replacement door modules, **prior to disassembly**; make a backup copy of the current DDM & PDM programming. This will simplify and expedite programming the replacement DDM & PDM.

Mirror Feature	Driver's Door Module			Passenger's Door Module		
Power Fold - Disabled	740-03-01	0000	4B	741-03-01	0000	4C
Power Fold - Enabled	740-03-01	8000	CB	741-03-01	8000	CC
Turn Signals Only - without Puddle Lamps or BLIS	740-04-01	7000	BC	741-04-01	7000	BD
Turn Signals & Puddle Lamps - without BLIS	740-04-01	F000	3C	741-04-01	F000	3D
Turn Signals & BLIS - without Puddle Lamps	740-04-01	7400	C0	741-04-01	7400	C1
Turn Signals, Puddle Lamps & BLIS	740-04-01	F400	40	741-04-01	F400	41

Memory - Disabled	740-06-01	60AE		741-06-01	60AF	
Memory - Enabled	740-06-01	E02E		741-06-01	E02F	

Lariat Door Harness – Driver’s Side Door Lock Connector Modification

- XLT driver’s side door harness has a 4 pin C505 connector at door lock. Lariat driver’s side door harness has 8 pin C541 connector. 4 Wires from terminals #7, 6, 8 and 2 respectively must be removed from C541 connector and transferred to Pins 1, 2, 3 & 4 of C505. Refer to attached wiring diagrams

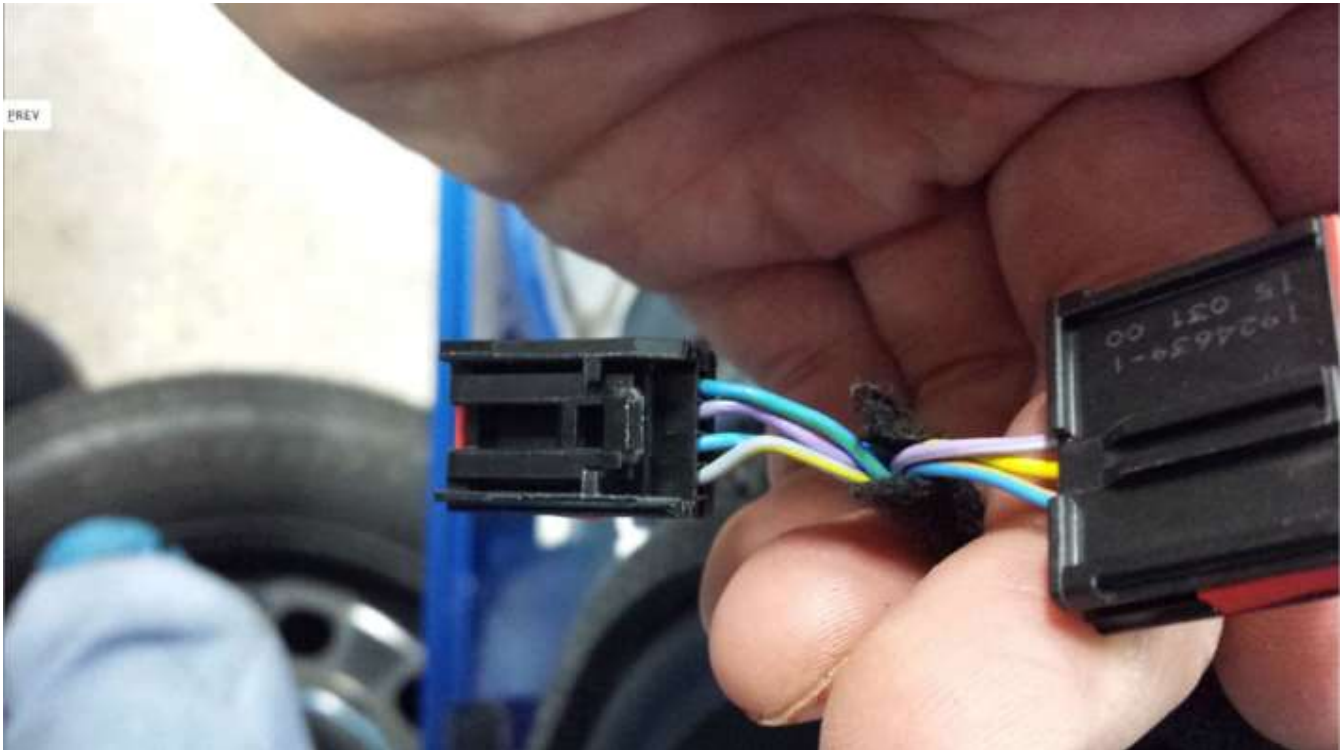

Navigation: Back Forward CS05

Connector:	Description	Color	Harness	Base Part #	Service Pigtail
C505	FRONT DOOR LOCK SWITCH LH	BK	14631	part# N/A	See Below

[Check for Terminal Part Numbers](#)

Pin	Circuit	Gauge	Circuit Function	Qualifier
1	CPL42 (DV-YE)	22	SWITCH - TRIM DOOR LOCK (DRIVER) # LOCK	
2	RPFW03 (BU-GR)	22	CTRL MOD - POWER WINDOW SWITCH DRIVER RETURN	
3	CPL43 (VT-OR)	22	SWITCH - TRIM DOOR LOCK (DRIVER) # UNLOCK	
4	CPL77 (BU-GR)	22	CTRL MOD - DOOR LOCK # SWITCH-TRIM DOOR LOCK DRIVER ILLUMINATION	

Connector:	Description	Color	Harness	Base Part #	Service Pigtail
C541	FRONT DOOR LOCK SWITCH LH	BK	14631	part# N/A	See Below

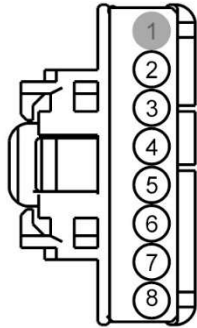

Check for Terminal Part Numbers

Pin	Circuit	Gauge	Circuit Function	Qualifier
1	-	-	Not Used	
2	CPL77 (BU-GN)	22	CTRL MOD - DOOR LOCK # SWITCH TRIM DOOR LOCK DRIVER ILLUMINATION	
3	CPS17 (BU-OG)	22	SWITCH - MEMORY DRIVER P3	
4	CPS18 (YE)	22	SWITCH - MEMORY DRIVER P2	
5	CPS15 (VT-WH)	22	SWITCH - MEMORY DRIVER P1	
6	RPW03 (BU-GN)	22	CTRL MOD - POWER WINDOW SWITCH DRIVER RETURN	
7	CPL42 (GY-YE)	22	SWITCH - TRIM DOOR LOCK (DRIVER) # LOCK	
8	CPL43 (VT-GY)	22	SWITCH - TRIM DOOR LOCK (DRIVER) # UNLOCK	

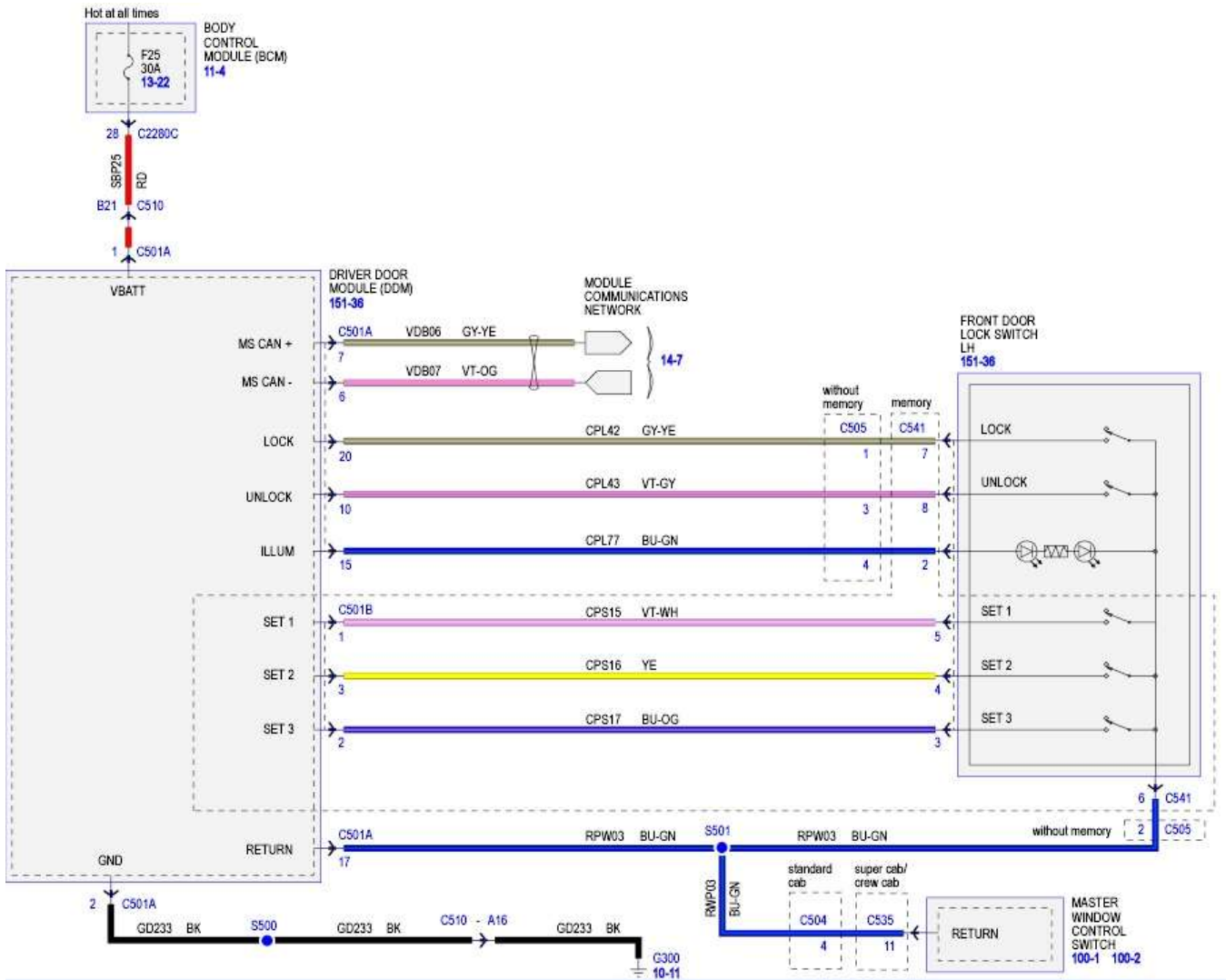

Spot Lamp Enable – choose Method A or B

A. Enabling Spot Lamps by Wiring Harness Modification (Spot Lamps Function Above 5 MPH)**)

- Cut / terminate CLF 76 GY wire (pin #2) approx. 1" behind Spot Lamp Module C2506B Connector. Tape and secure CLF 76 GY wire protruding from dash harness – this wire will no longer be used. Run short jumper wire from SBB16 VT-RD wire (pin #1) of C2506B connector to CLF 76 GY wire protruding from C2506B connector. SBB16 VT-RD wire now provides constant 12V+ to Pin #2 of C2506B connector. Refer to attached wiring diagram.

****Note:** if choosing this method to enable the spot lamps, it is possible to exit the vehicle and inadvertently leave the spot lamps on as they are no longer controlled by the BCM.

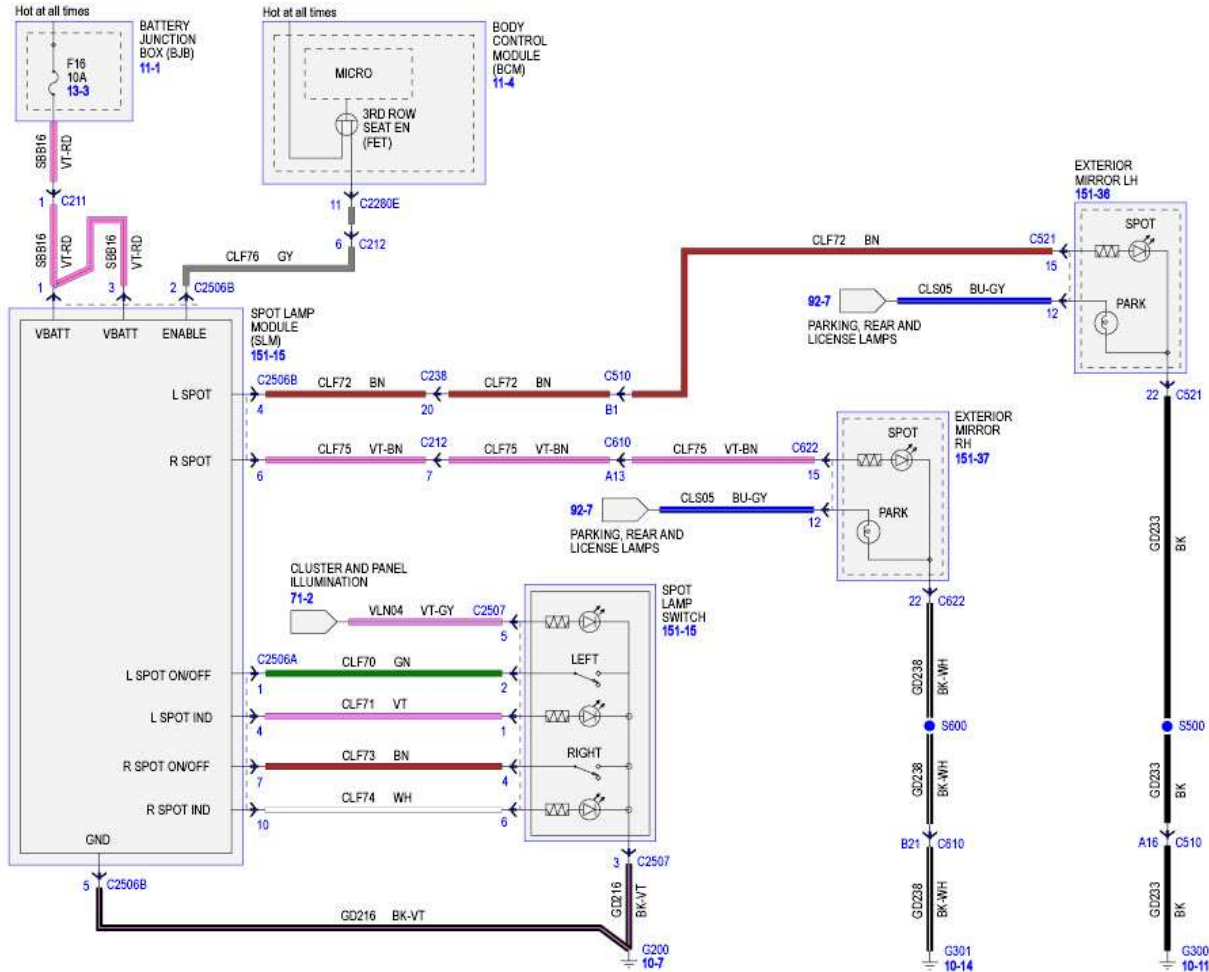

B. Enabling Spot Lamps Using FORScan (Spot Lamps Do Not Function Above 5 MPH)

- Using FORScan change BCM address 726-56-01 from XXXX X0XX XXXX to XXXX X1XX XXXX (Spotlight Cfg: **0**=disable, **1**=enable). In most applications the new 726-56-01 value will be 0000 0100 0186.

Auto Fold Options

1. **Step #1 is necessary for Trailer Tow Mirrors only.** For Non-Trailer Tow Mirrors proceed to step #2.

- Pins # 18 and 19 (mirror fold in/out) of the 22 pin mirror harness connector (Driver side - C521 & Passenger side - C622) must be swapped – refer to attached C521 & C622 connector views
 - i. Remove interior sail trim panel from door
 - ii. Unplug exterior mirror wiring harness connector and remove the red lock. The outside edge just needs to be flexed enough to slide away from the connector.
 - iii. Remove pins # 18 & 19 and swap their positions**:

1. Driver side colors: Pin # 18 - Violet / Brown & Pin # 19 - Green / Violet
2. Passenger side colors: Pin # 18 Brown & Pin # 19 White / Orange

**On the wire side of the 22 pin mirror harness connector you will see small numbers in the corners indicating pin location - 1, 11, 12 & 22

Note: If you damage a wire terminal, replacement pigtail part # is DU2Z-14474-CA (WT-1002) is available

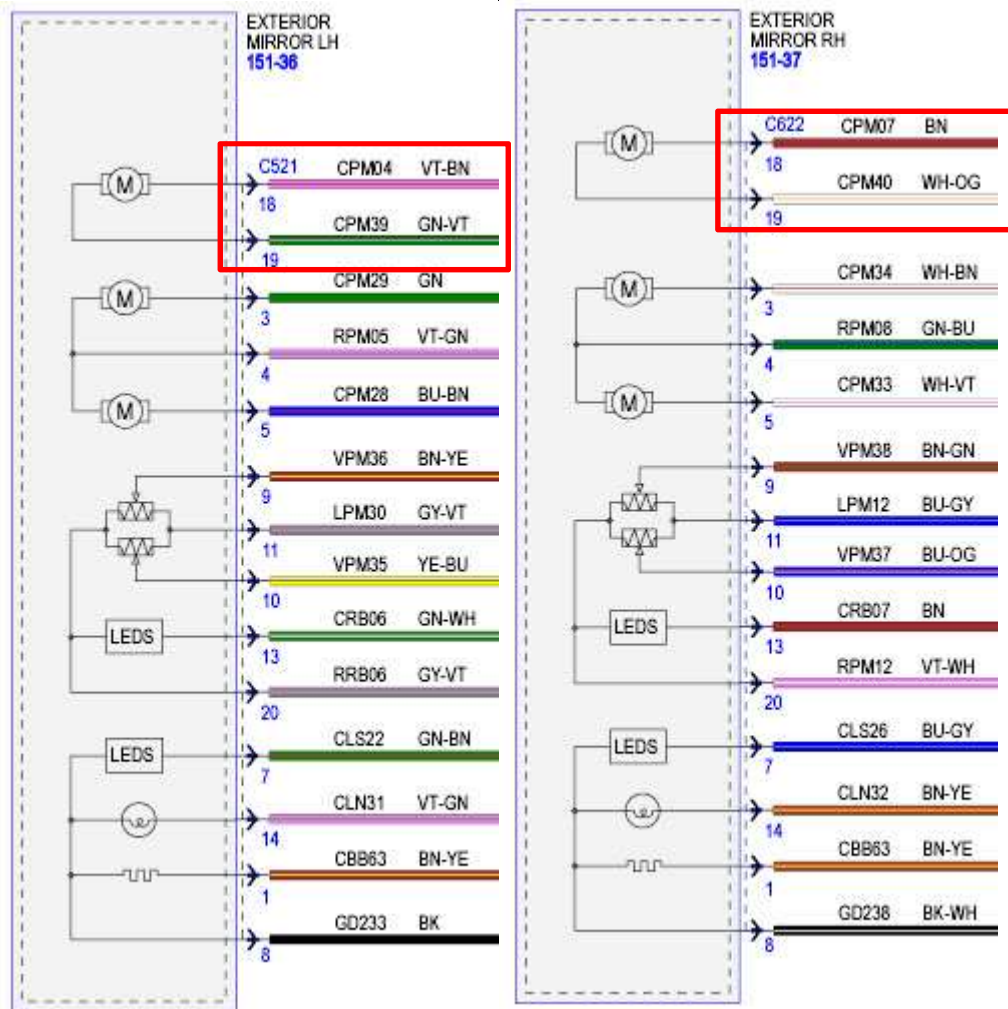

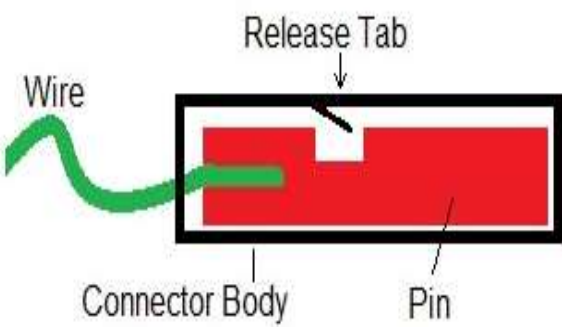
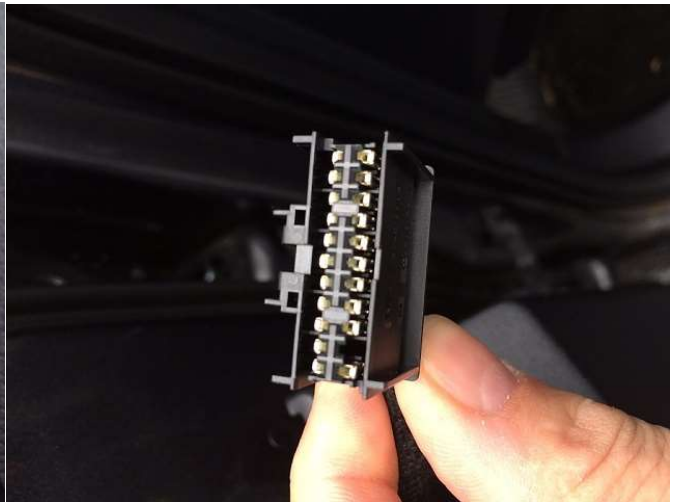

- Reprogram Driver & Passenger Door Modules (both Trailer Tow & Non-Trailer Tow Mirrors). Note:
There are 2 programming options for Auto Fold: Auto Fold with Key Fob & Auto Fold Lincoln Style.

Auto Fold with Key Fob:

Mirror Feature	Driver's Door Module			Passenger's Door Module		
Auto Fold with Key Fob	740-03-01	8800	D3	741-03-01	8800	D4
	740-12-01	F04A		741-12-01	F04B	

Auto Fold Lincoln Style:

Mirror Feature	Driver's Door Module			Passenger's Door Module		
Auto Fold - Lincoln Style	740-03-01	8840	13	741-03-01	8840	14
	740-12-01	F04A		741-12-01	F04B	

Note: Mirrors will fold closed via lock button on fob but will only unfold when driver's door is opened/closed.

This is helpful if you find yourself often unlocking truck to grab something from inside but don't want the mirrors unfolding (provided you use any door but driver's for entry)

Power Door Window Initialization

 **WARNING: Keep objects and body parts clear of the glass panel when carrying out the initialization procedure. During the initialization procedure, the glass panel closes with high force and cannot detect objects in its path. Failure to follow this instruction may result in serious personal injury.**

Note: Perform one-touch up re-calibration with the door closed. Calibrating with the door open will cause the window to continuously bounce back.

- Start the engine.
- Lift and hold the window control switch until the door window is fully closed.
- Release the window control switch.
- Lift and hold the window control switch again for at least one second.
- Press and hold the window control switch until the door window is fully open.
- Release the window control switch.
- Lift and hold the window control switch until the window is fully closed.
- Test for correct window operation by carrying out the one-touch down and one-touch up features.

Power Mirror Synchronization

NOTE: The power folding mirrors may need to be synchronized any time the mirrors are folded or unfolded without using the folding switch, or if a new power folding mirror is installed.

NOTE: The power telescoping mirrors may need to be synchronized any time the mirrors are extended or retracted without using the telescoping switch, or if a new power telescoping mirror is installed.

NOTE: If the power folding or power telescoping mirrors are continuously electronically moved, the power lockout feature disables the system for approximately 3-10 minutes to prevent damage to the power fold motors. After 3-10 minutes have elapsed, normal operation resumes.

NOTE: The truck power folding mirror procedure is shown in the videos, other vehicles and power telescoping mirror procedure are similar.

1. Fold or retract both mirrors by hand.
2. Using the power folding/power telescoping mirror switch, operate the mirrors until an audible click is heard.
3. Operate the power folding or power telescoping mirrors an additional 3 to 4 times to synchronize the mirrors.