

Engine Oil Pressure (EOP) Sensor

Materials

| Name | Specification |
|--|---------------|
| Motorcraft® Thread Sealant with PTFE TA-24-B | WSK-M2G350-A2 |

Removal

NOTICE: During engine repair procedures, cleanliness is extremely important. Any foreign material, including any material created while cleaning gasket surfaces, that enters the oil passages, coolant passages or the oil pan, can cause engine failure.

NOTE: Removal steps in this procedure may contain installation details.

1. With the vehicle in NEUTRAL, position it on a hoist.
Refer to: [Jacking and Lifting - Overview](#) (100-02 Jacking and Lifting, Description and Operation).
2. **NOTE:** Vehicles come with an underbody shield or a skid plate.

If equipped, remove the bolts and the underbody shield.
Torque: 30 lb.ft (40 Nm)

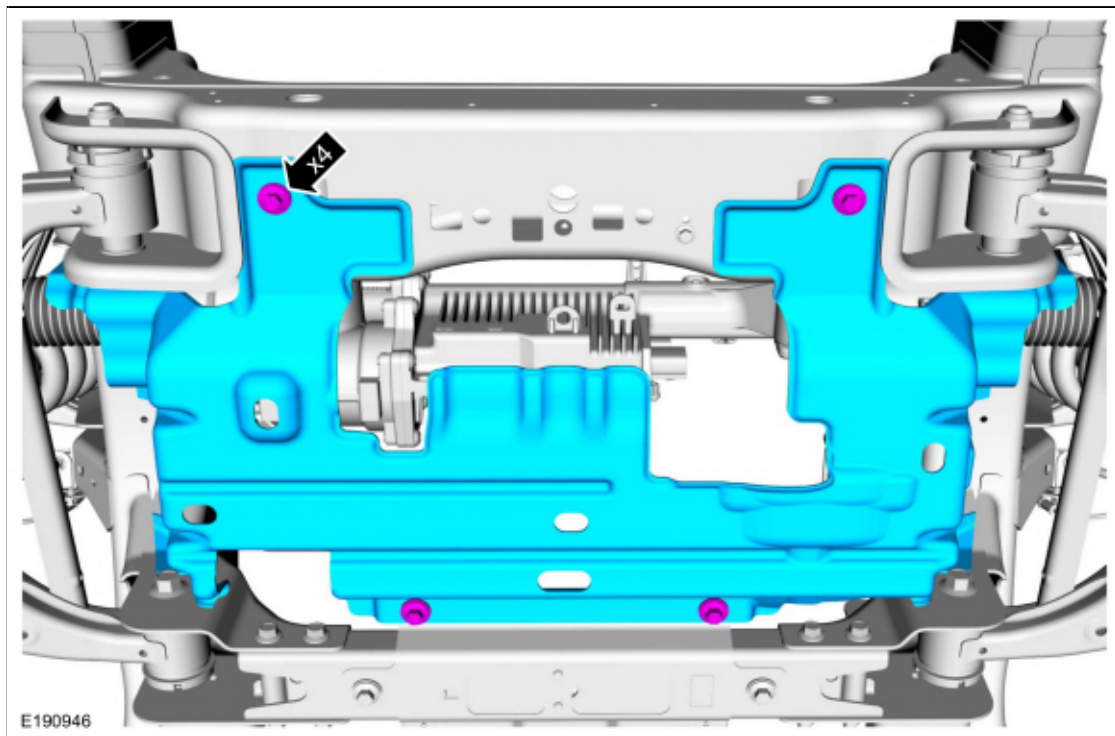

3. **NOTE:** Vehicles come with an underbody shield or a skid plate.

If equipped, remove the bolts and the skid plate.
Torque: 30 lb.ft (40 Nm)

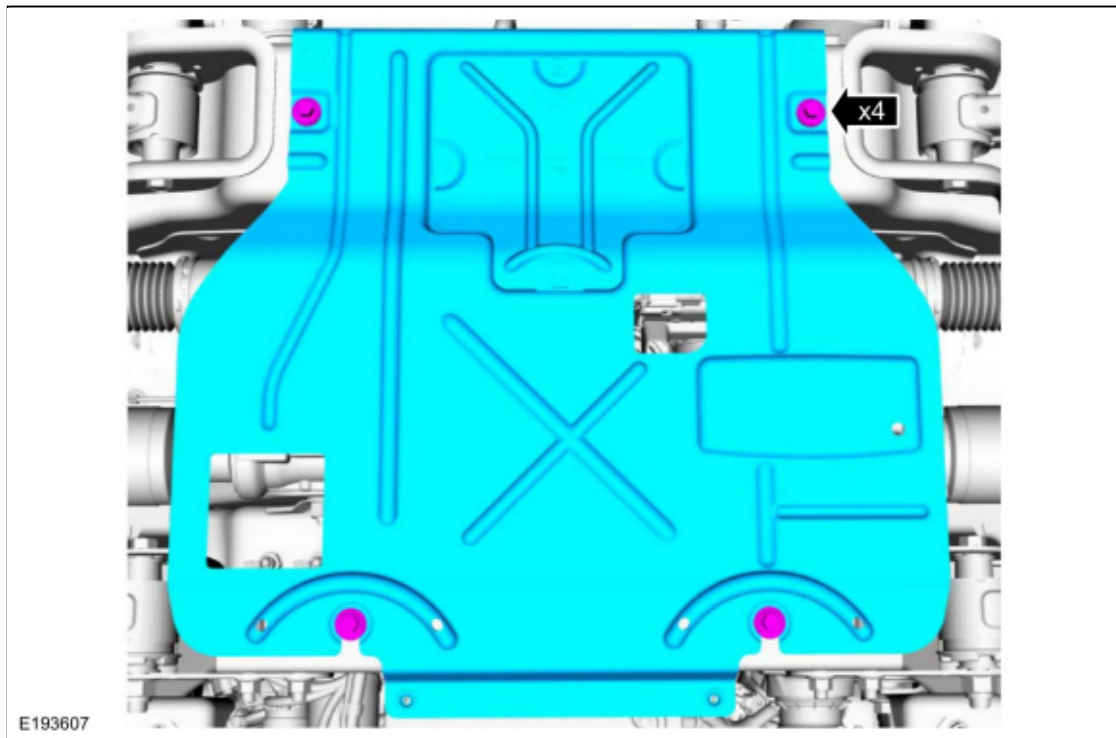

4. If equipped, remove the bolts and the oil drain gutter.
Torque: 62 lb.in (7 Nm)

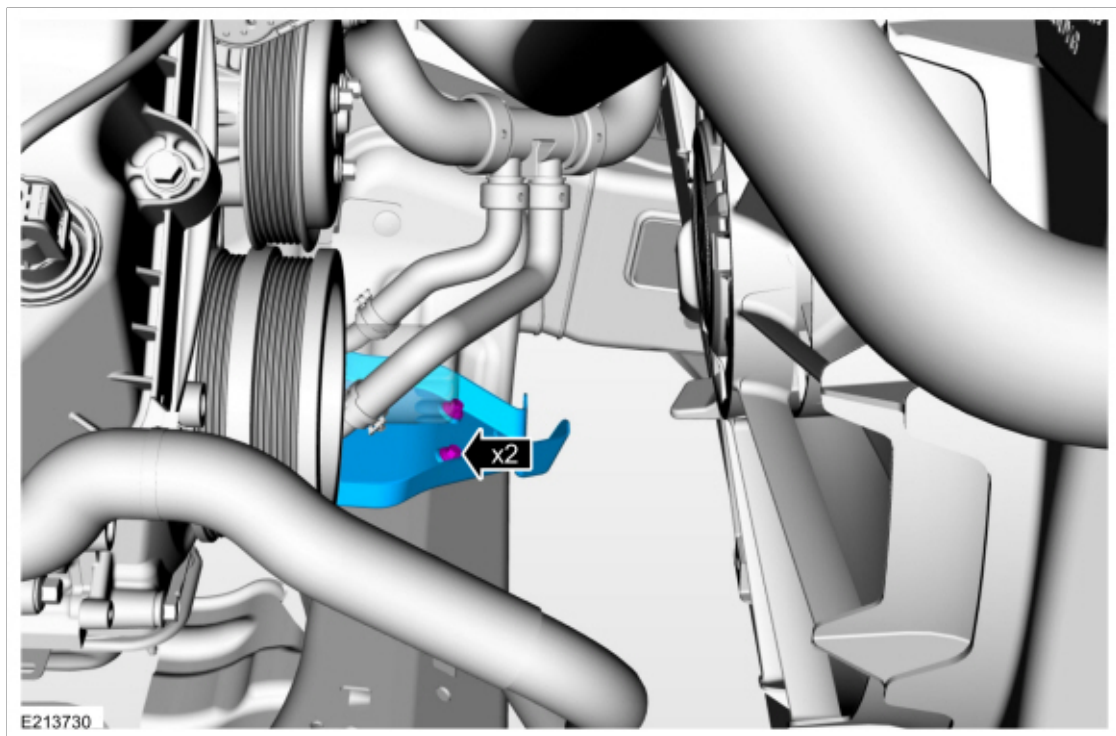

5. Disconnect the EOP sensor electrical connector.

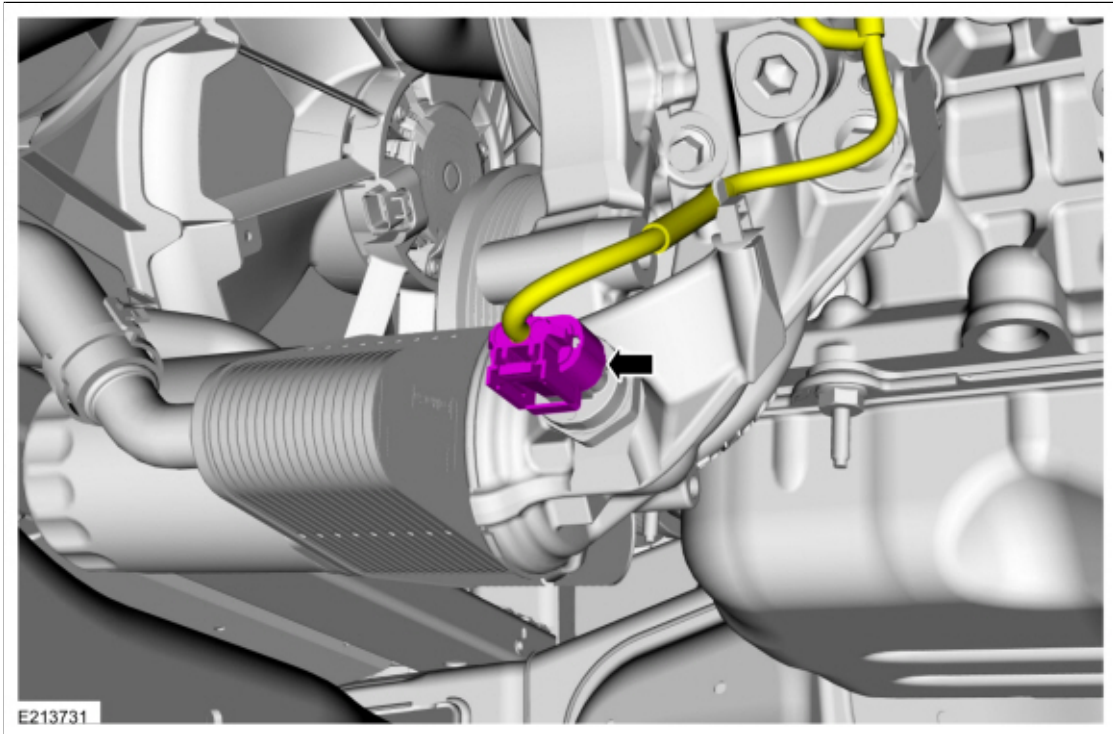

6. Using a crowfoot, remove the EOP sensor.
Torque: 133 lb.in (15 Nm)

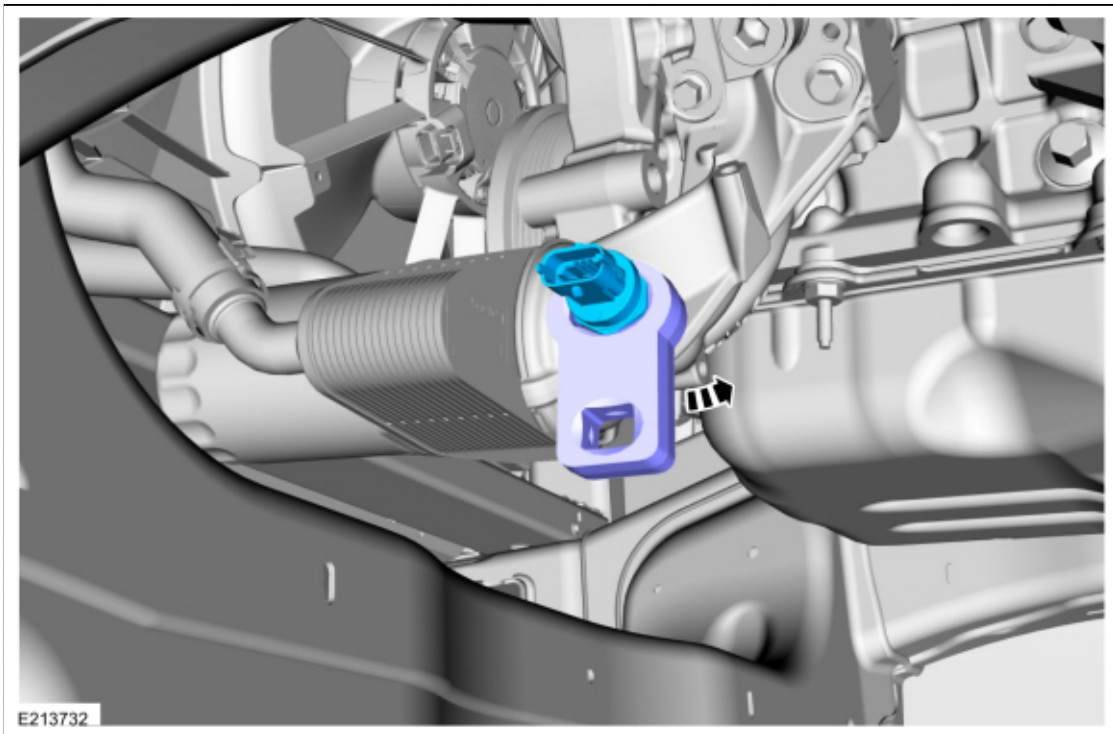

Installation

NOTE: *If the EOP sensor is to be reused, apply thread sealant.*

1. To install, reverse the removal procedure.

Material: Motorcraft® Thread Sealant with PTFE / TA-24-B (WSK-M2G350-A2)

Copyright © 2017 Ford Motor Company
