Rear Door Alignment - SuperCab

Base Part Number: 24630

Inspection**NOTE:** *LH side shown, RH side similar.***NOTE:** *Removal steps in this procedure may contain installation details.*

1. Inspect the rear door-to-body dimensions.
Refer to: [Body and Frame](#) (501-26 Body Repairs - Vehicle Specific Information and Tolerance Checks, Description and Operation).

Adjustment**All alignments**

1. Open the front door.



2. Open the rear door.

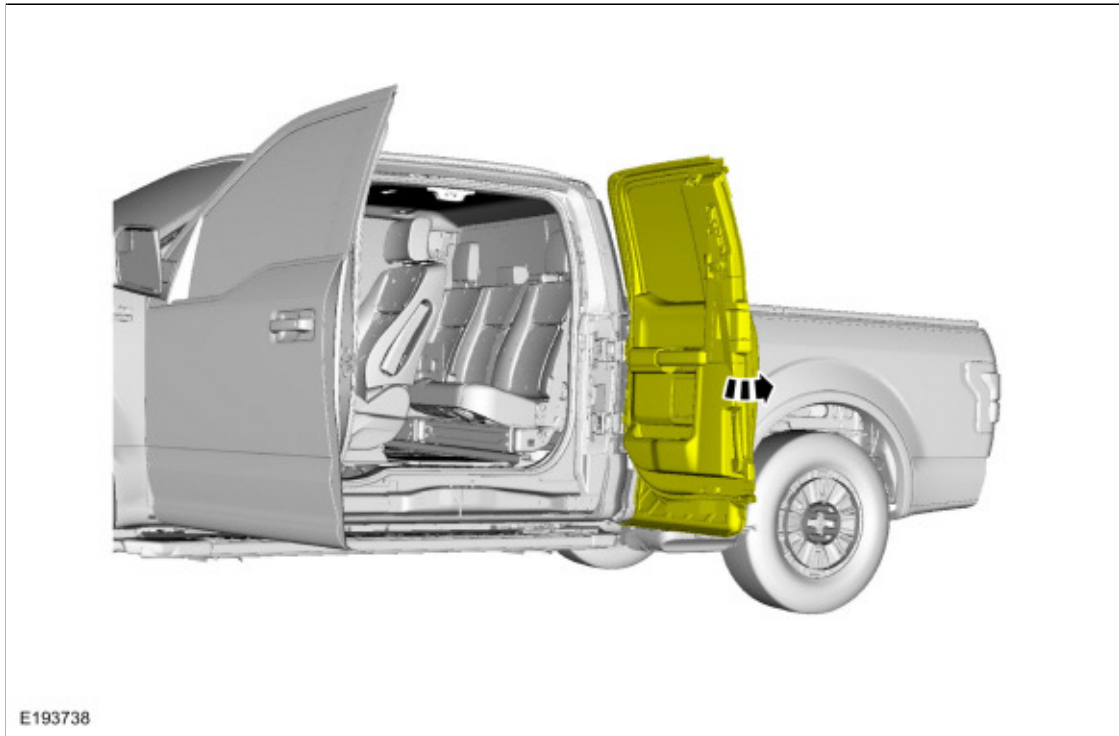

3. Remove the upper striker assembly trim panel cover.

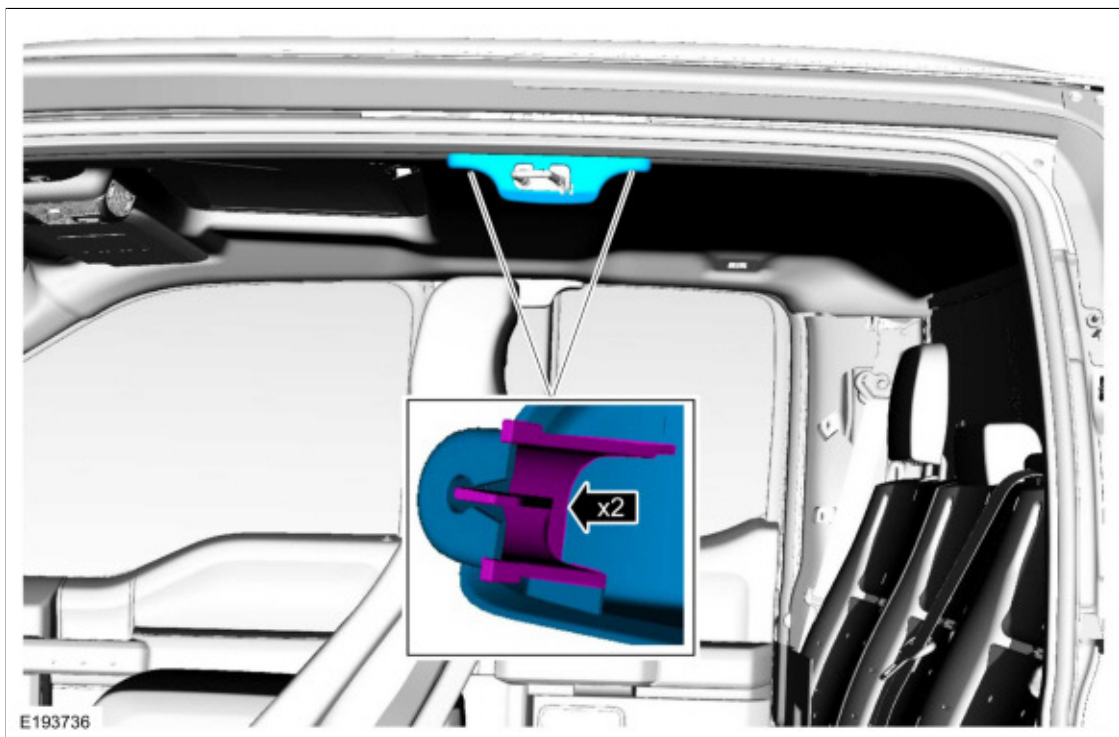

4. Remove the bolts and the upper striker assembly.
Torque: 18 lb.ft (25 Nm)

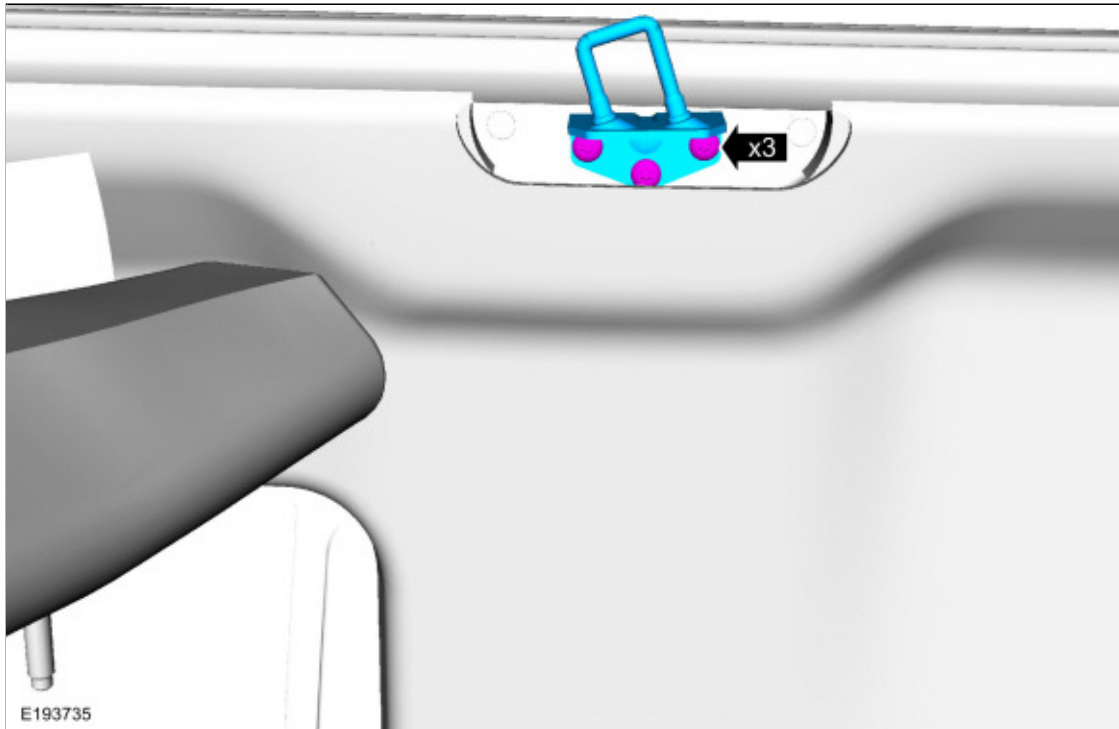

5. Remove the bolts and the lower striker assembly.
Torque: 18 lb.ft (25 Nm)

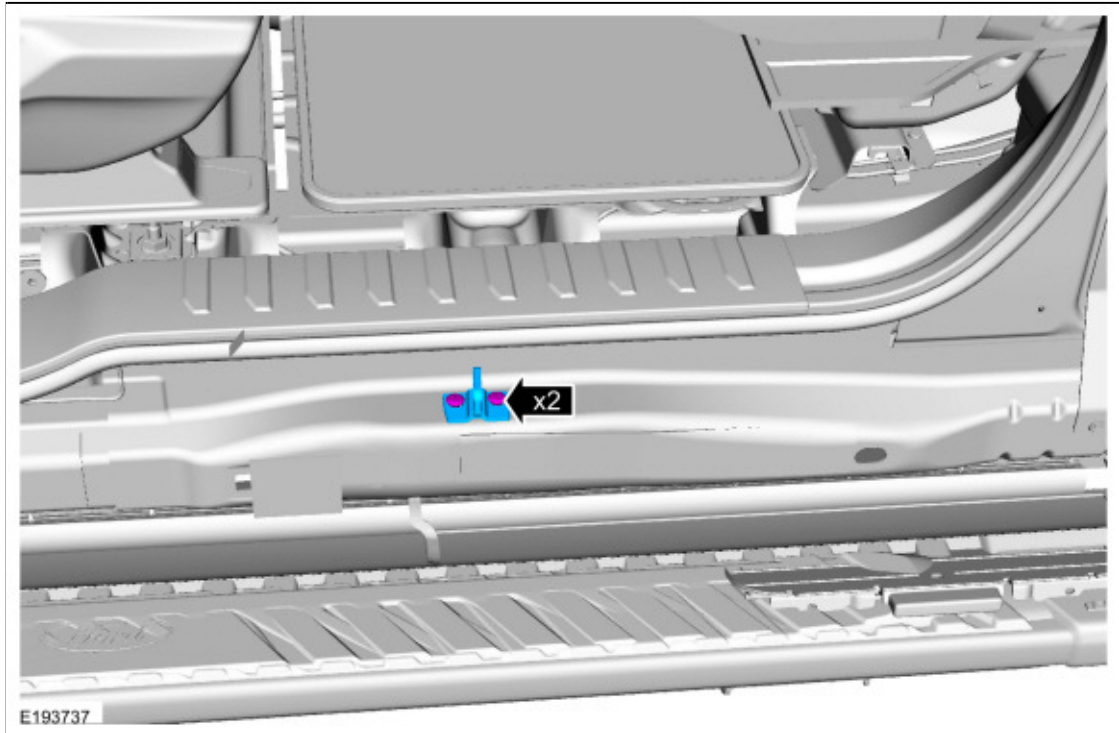

Rear door in and out, up and down alignment

6. Open the front door.

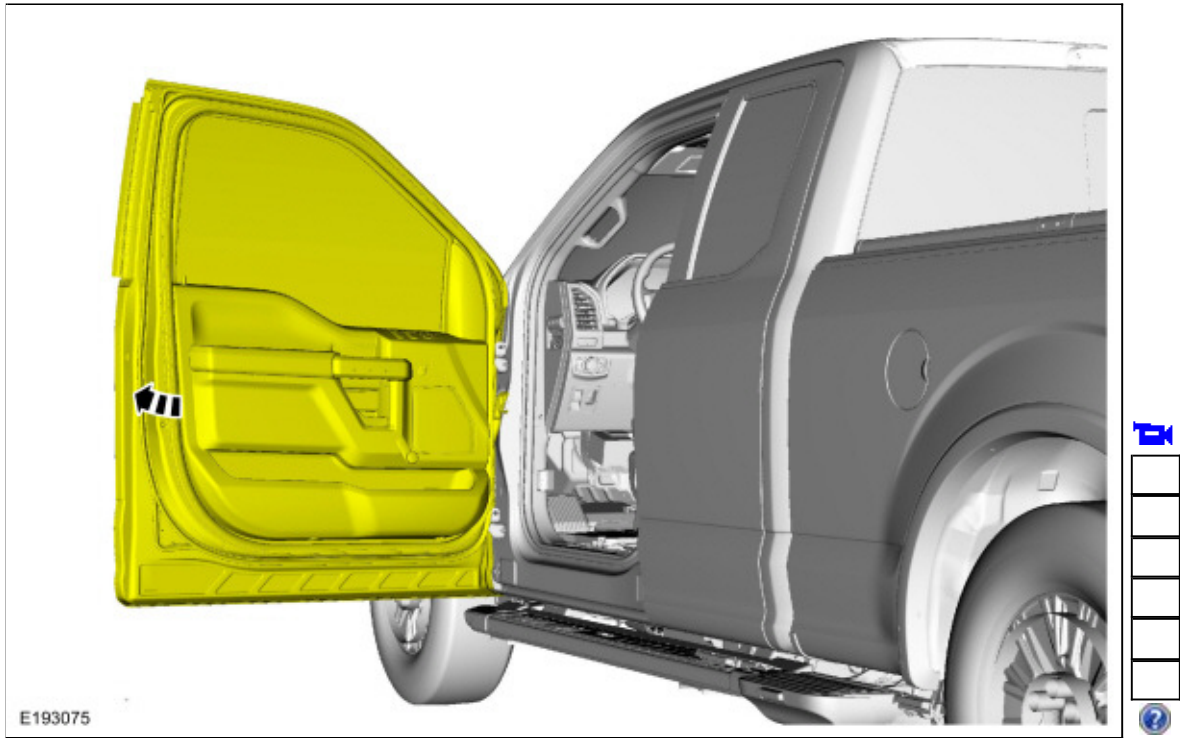

7. Open the rear door.

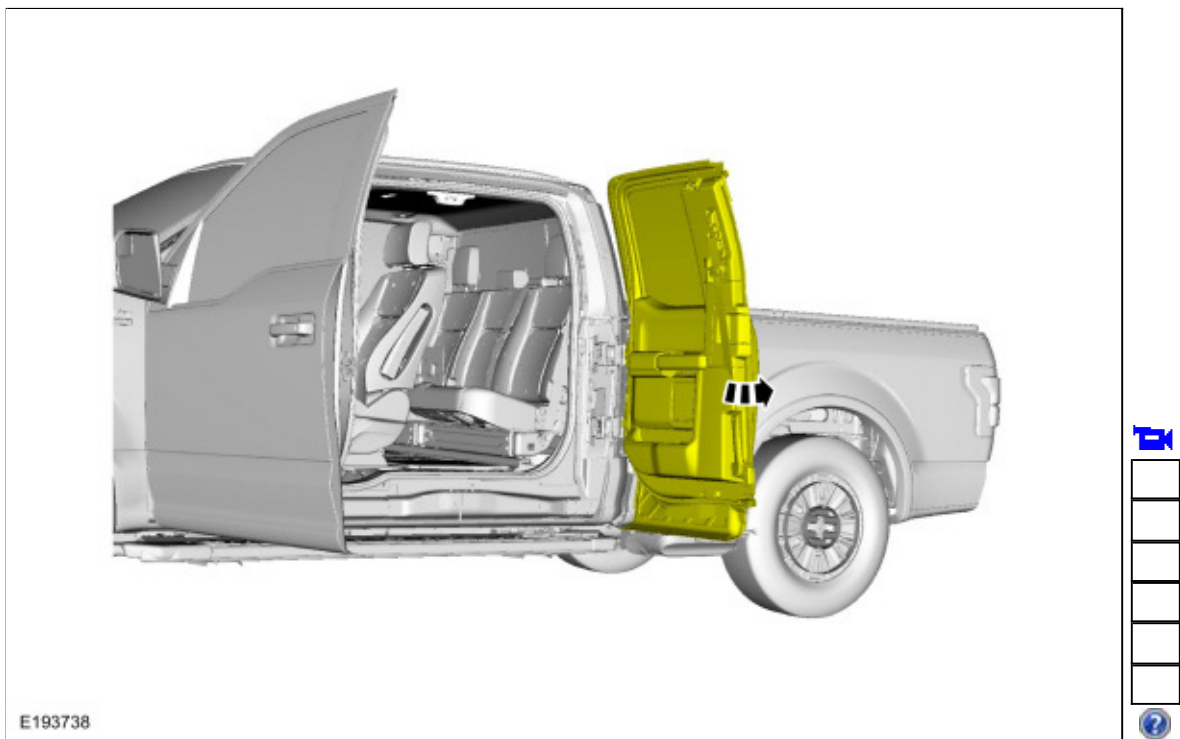

8. Loosen the bolts enough to permit movement of the door.



- Adjust the door to specification.
Refer to: [Body and Frame](#) (501-26 Body Repairs - Vehicle Specific Information and Tolerance Checks, Description and Operation).

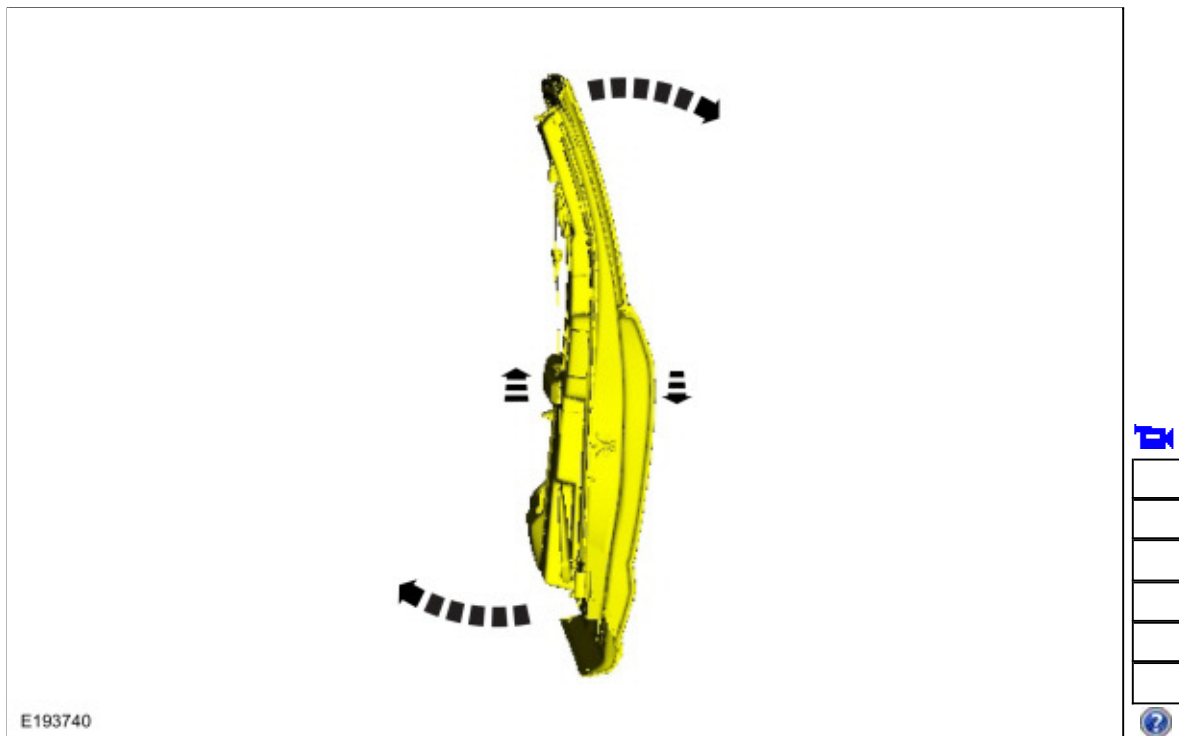

- Tighten the bolts.
Torque: 20 lb.ft (27.5 Nm)



Rear door fore, aft and tilt alignment

11. Remove the B-pillar trim panel.
Refer to: [B-Pillar Trim Panel - SuperCab](#) (501-05 Interior Trim and Ornamentation, Removal and Installation).
12. Open the front door.



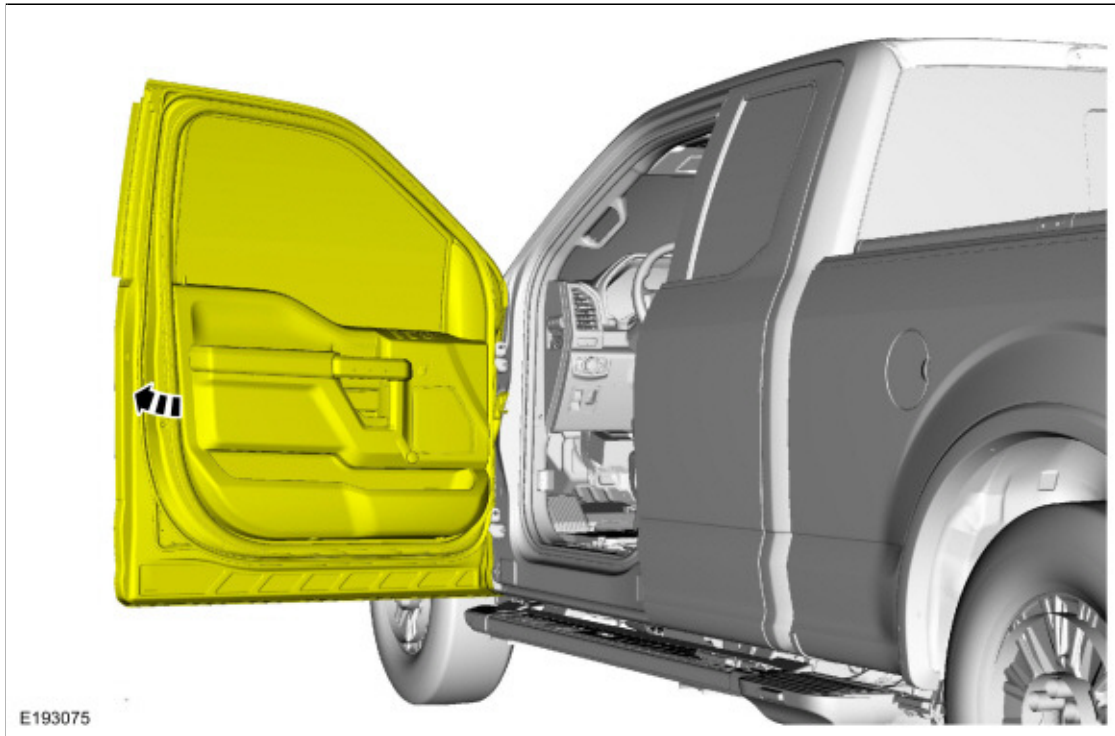

13. Open the rear door.

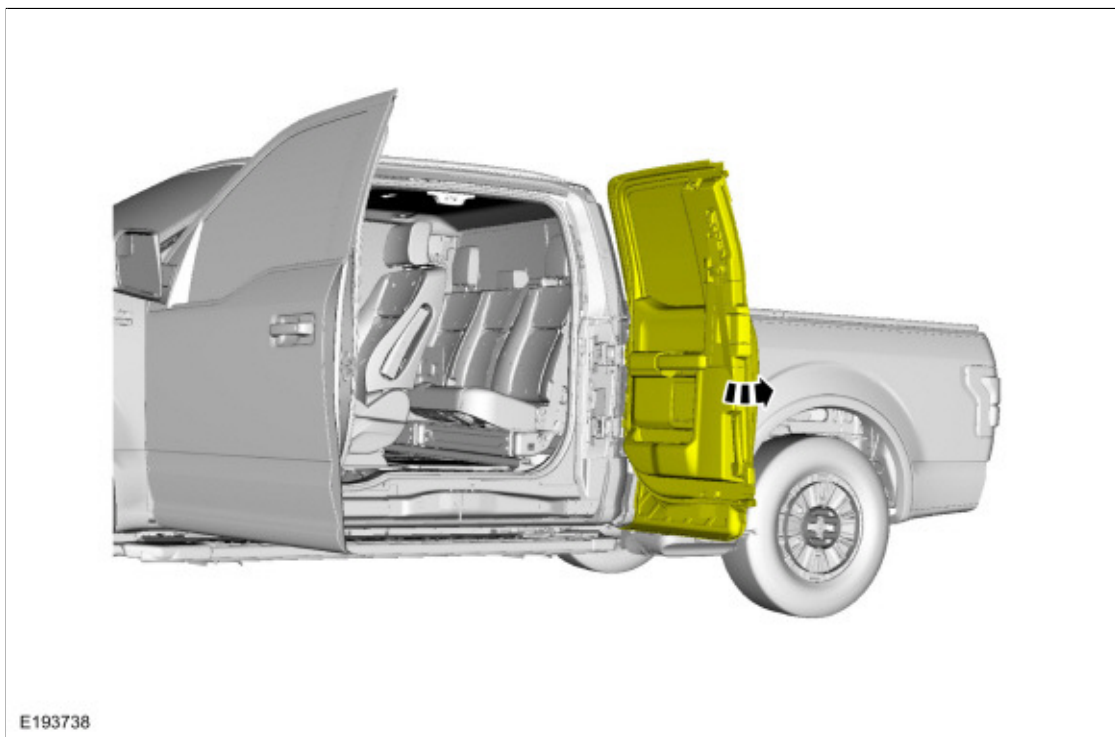

14. Remove the bolt and position aside the safety belt retractor.
Torque: 30 lb.ft (40 Nm)

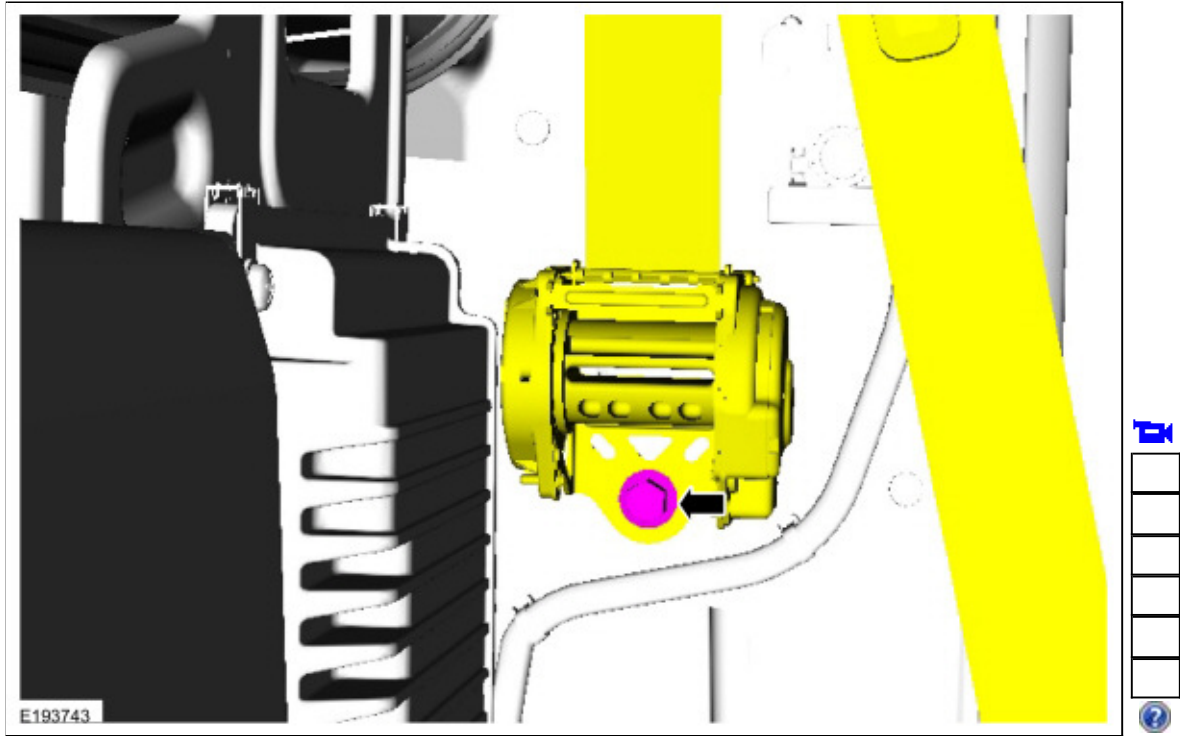

15. Remove the rear body access trim panel.

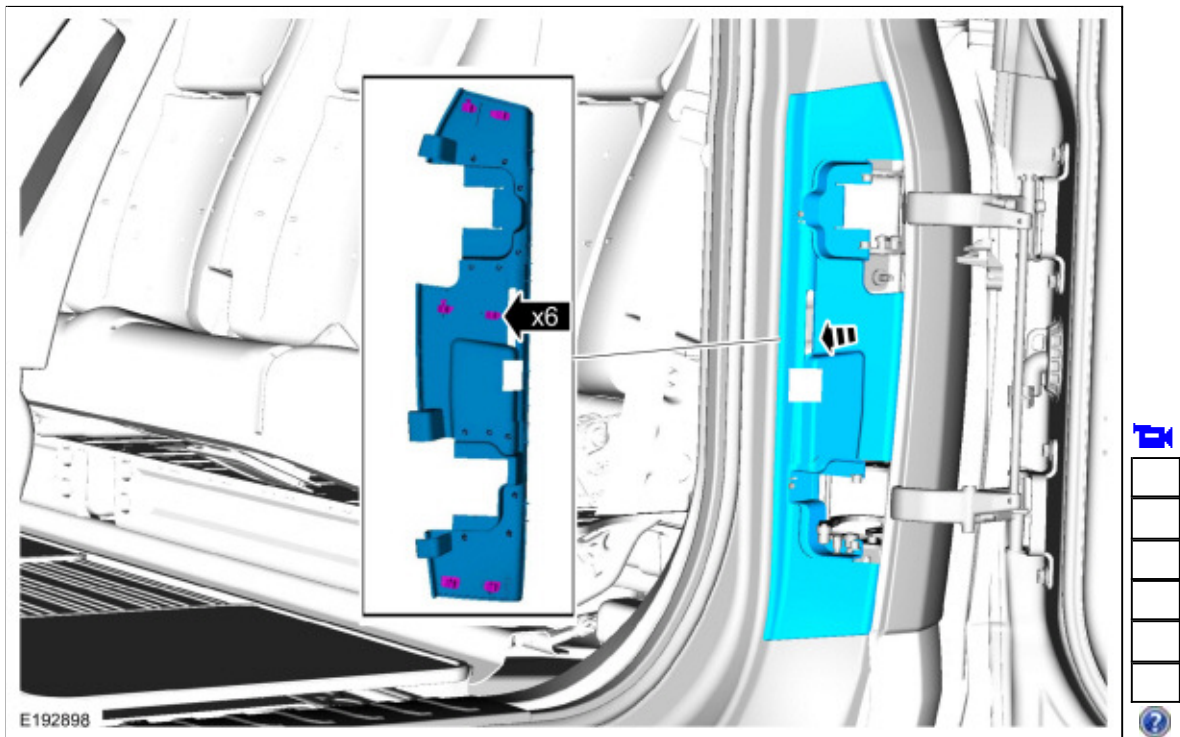

16. Loosen the bolts enough to permit movement of the door.



17. Carefully close the door.

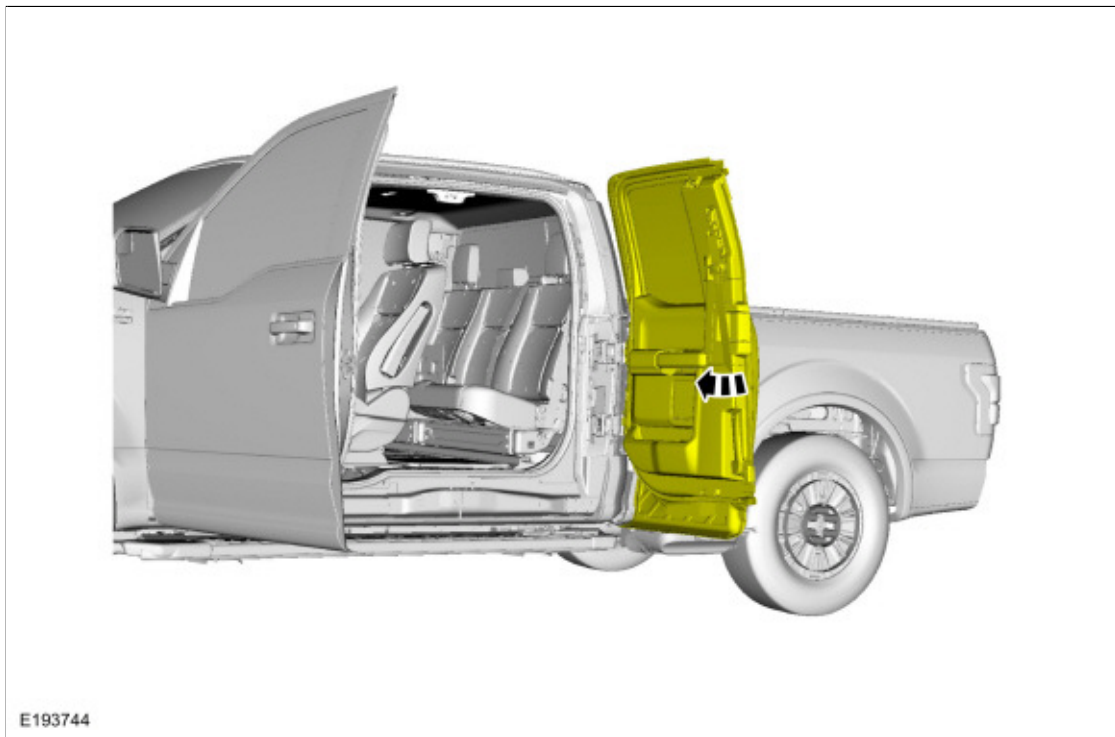

18. Adjust the door to specification.
Refer to: [Body and Frame](#) (501-26 Body Repairs - Vehicle Specific Information and Tolerance Checks, Description and Operation).

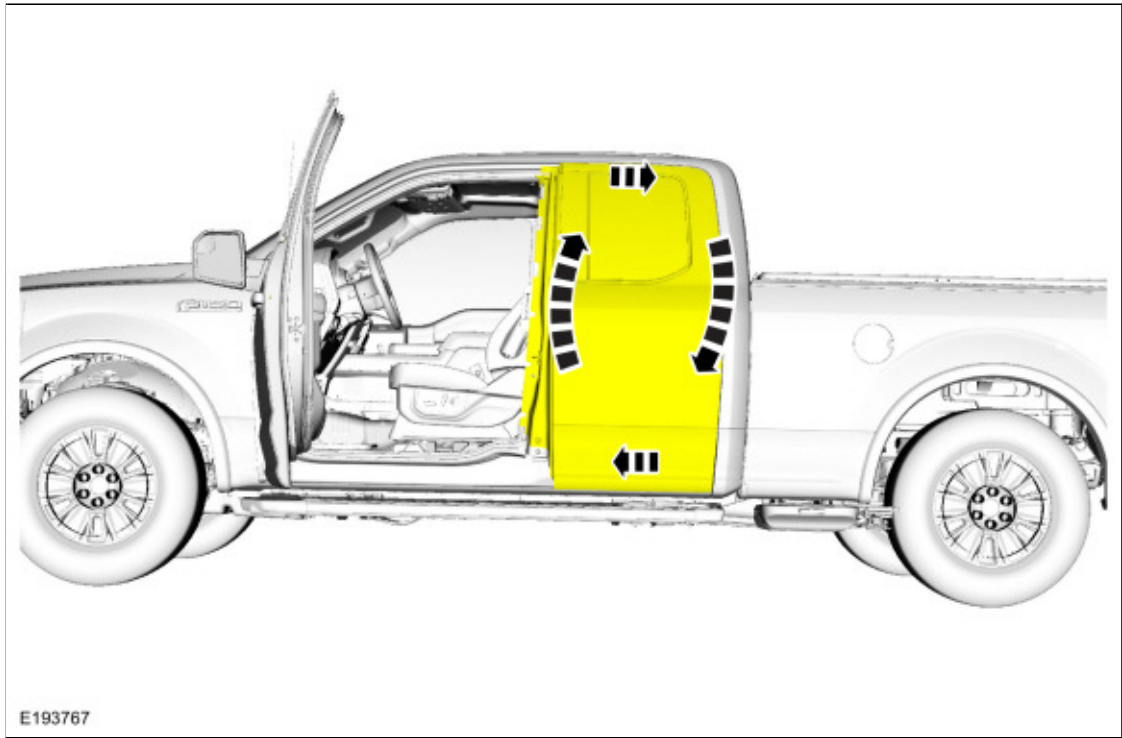

19. Carefully open the door.

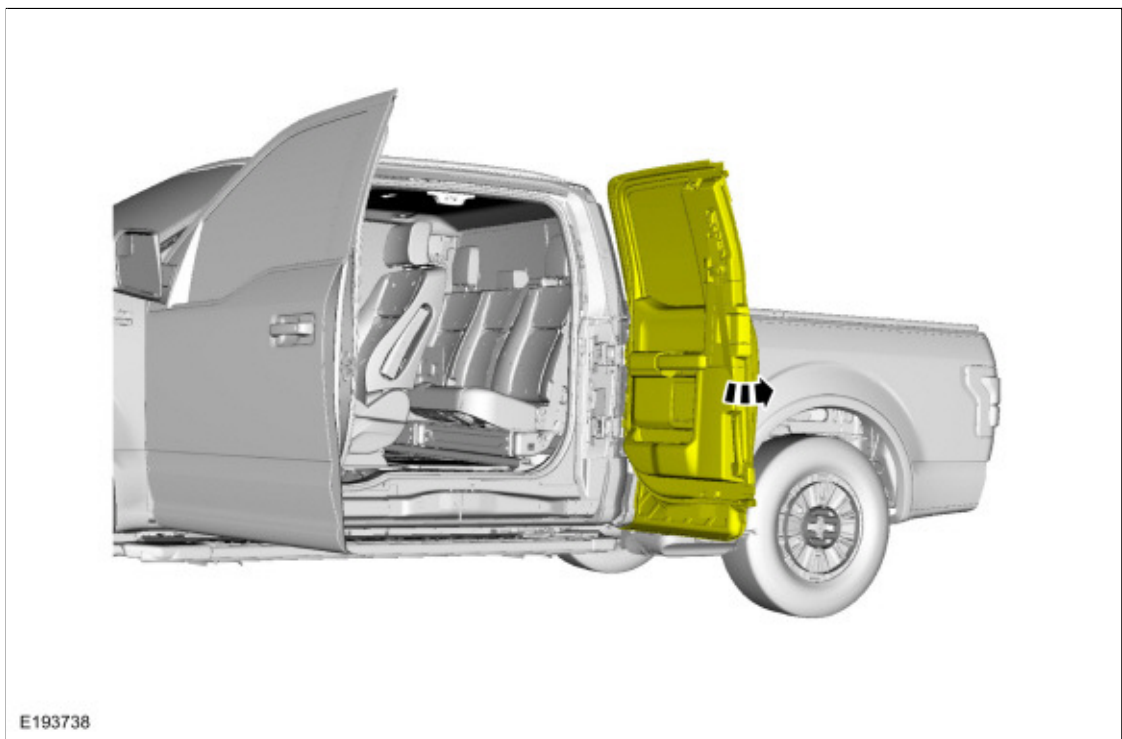

20. Tighten the bolts.
Torque: 26 lb.ft (35 Nm)



All alignments

21. Inspect the body-to-rear door dimensions.
Refer to: [Body and Frame](#) (501-26 Body Repairs - Vehicle Specific Information and Tolerance Checks, Description and Operation).

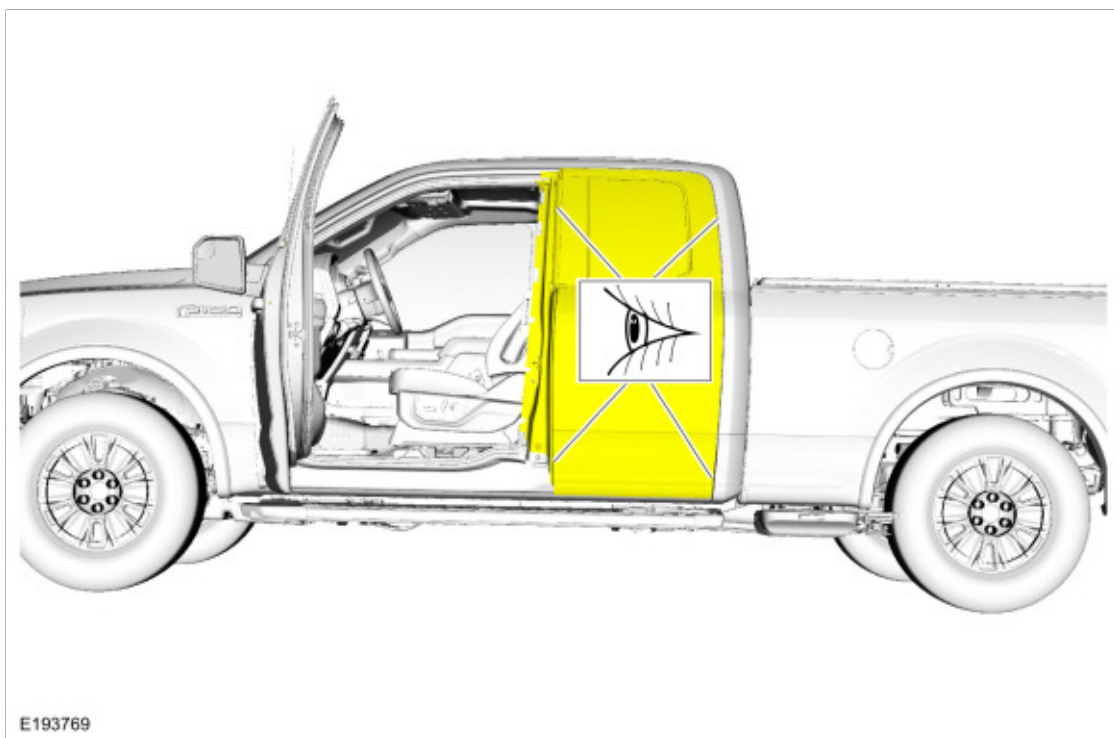

22. Install the removed components.

- During installation, make sure the safety belt webbing is not twisted and the safety belts and buckles are accessible to the occupants.

Copyright © 2017 Ford Motor Company
