

## **2015/16 F150 SCrew Power Fold & Extend Trailer Tow Mirror Retrofit**

### **Trailer Tow Mirrors**

- XL (100A) Trailer Tow mirror---FL3Z 17682 AB and FL3Z 17683 AB - Manual mirrors w/black skull caps includes: manual fold & extend, without power adjust/heat/signals/spot lamps/LED security approach lamps/BLIS, memory, auto dimming (driver's side only) or side camera
- XL (101A)/XLT (300A/301A/302A) Trailer Tow mirror---FL3Z 17682 AC and FL3Z 17683 AC - Power mirrors w/black skull caps includes: power adjust/heat/signals/with manual fold/extend/spot lamps/LED security approach lamps/without BLIS, memory, auto dimming (driver's side only) or side camera
- Lariat (500A) Trailer Tow mirror---FL3Z 17682 AD and FL3Z 17683 AD Power mirrors with black skull caps includes: power adjust/heat/signals/power fold & extend/memory/auto dimming (driver's side only)/spot lamps/LED security approach lamps/without BLIS or side camera
- Lariat (500A) Trailer Tow mirror---FL3Z 17682 AE and FL3Z 17683 AE Power mirrors with chrome skull caps includes: power adjust/heat/signals/power fold & extend/memory/auto dimming (driver's side only)/spot lamps/LED security approach lamps/without BLIS or side camera
- Lariat (501A & 502A wo/Technology Pkg.) Trailer Tow mirror---FL3Z 17682 AF and FL3Z 17683 AF Power mirrors with black skull caps includes: power adjust/heat/signals/power fold & extend/memory/auto dimming (driver's side only)/with BLIS/spot lamps/LED security approach lamps/without side camera
- Lariat (501A & 502A wo/Technology Pkg.) Trailer Tow mirror---FL3Z 17682 AG and FL3Z 17683 AG Power mirrors with chrome skull caps includes: power adjust/heat/signals/power fold & extend/memory/auto dimming (driver's side only)/spot lamps/LED security approach lamps/with BLIS/without side camera
- Lariat (502A – w/Technology Pkg.) Trailer Tow mirror---FL3Z 17682 AH and FL3Z 17683 AH Power mirrors with black skull caps includes: power adjust/heat/signals/power fold & extend/memory/auto dimming (driver's side only)/spot lamps/LED security approach lamps/with BLIS and side camera
- Lariat (502A w/Technology Pkg.) Trailer Tow mirror---FL3Z 17682 AJ and FL3Z 17683 AJ Power mirrors with chrome skull caps includes: power adjust/heat/signals/power fold & extend/memory/auto dimming (driver's side only)/spot lamps/LED security approach lamps/with BLIS and side camera

### **Door Harnesses**

- Lariat harness 22 pin, FL3Z-14631-A and FL3Z-14630-E (supports Power fold, power telescope & memory). Requires modification (4 terminals must be repinned) of 8 pin connector (C541) to 4 pin connector (C505) for LH front door lock switch without memory. Connectors for door switch and ambient lighting won't be used.
- XLT harness 22 pin, FL3Z-14631-F and FL3Z-14630-C (supports spot/puddle lamps and BLIS. Does NOT support Power fold, power telescope or memory)

**Door Modules**

- With BLIS **built on 10/20/14 thru to 4/7/16**--DG9Z 14B291 VJ (Driver) FK7Z 14B291 C (Passenger)  
**(Required for Power Fold)**
- With BLIS **built on 4/8/16 thru 1/12/17**--DG9Z 14B291 WG (Driver) DG9Z 14B291 WH (Passenger)  
**(Required for Power Fold)**
- With BLIS **built on or after 1/13/17**--DG9Z 14B291 WP (Driver) DG9Z 14B291 WR (Passenger)  
**(Required for Power Fold)**

**Mirror Switch**

- Power fold only---- FL3Z 14529 CB
- Power fold and extend---- FL3Z 14529 BA

**Spot Lamps**

- Switch----FL3Z 13D730 EA
- Processor (module)---FU5Z 13C788 A – Requires a \$50 core deposit
- LH Dash vent trim which holds spot lamp switch----FL3Z 1504339 DB

**OEM Terminals to add Trailer Tow Mirror Power Telescope circuit to 14A005 XLT dash harness**

- DU2Z-14474-BA (WT-1001) Terminal – C265 Female Connector (RH Side of 14A005 Cab Harness – Engine Harness End)
- DU2Z-14474-CA (WT-1002) Terminal – C510 & C610 Female Connector (LH & RH side of 14A005 Cab Harness – Door Harness End)
- BU5T-14421-HA Terminal - C268 Male Connector (LH Side of 14A005 Cab Harness – Engine Harness End). **This terminal is NOT serviced through Ford Parts.** However this terminal can be salvaged from either of the 8 pin XLT door harnesses (C510 connector - pin A8 or A11, or C610 connector - pin A11 or A21). Suggest using 3U2Z-14A088-AB (WT-56814) 18-22 AWG terminal (splice kit) to connect salvaged terminals to additional wiring – see below.
- Belden (NAPA) 785105 20 AWG Green Primary Wire (Extend Function)
- Belden (NAPA) 785109 20 AWG White Primary Wire (Retract Function)

**Door Module Programming**

Mirror Feature	Driver's Door Module			Passenger's Door Module		
Power Fold - Disabled	740-03-01	0000	4B	741-03-01	0000	4C
Power Fold - Enabled	740-03-01	A000	EB	741-03-01	A000	EC

Turn Signals Only - without Puddle Lamps or BLIS	740-04-01	7000	BC	741-04-01	7000	BD
Turn Signals & Puddle Lamps - without BLIS	740-04-01	F000	3C	741-04-01	F000	3D
Turn Signals & BLIS - without Puddle Lamps	740-04-01	7400	C0	741-04-01	7400	C1
Turn Signals, Puddle Lamps & BLIS	740-04-01	F400	40	741-04-01	F400	41
Memory - Disabled	740-06-01	60AE		741-06-01	60AF	
Memory - Enabled	740-06-01	E02E		741-06-01	E02F	

### Lariat Door Harness – Driver’s Side Door Lock Connector Modification

- XLT driver’s side door lock has a 4 pin C505 connector. Lariat driver’s door harnesses has 8 pin C541 connector. 4 Wires from terminals #7, 6, 8 and 2 respectively must be removed from C541 connector and transferred to Pins 1, 2, 3 & 4 of C505. Refer to attached wiring diagrams

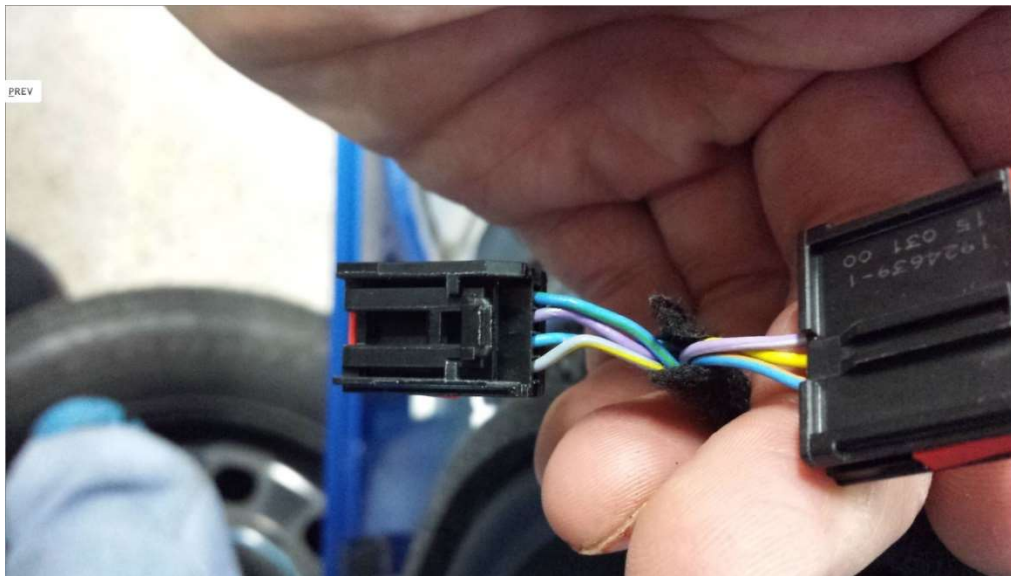

Connector: C505	Description: FRONT DOOR LOCK SWITCH LH	Color: BK	Harness: 14631	Base Part #: part# N/A	Service Pigtail: See Below
-----------------	--	-----------	----------------	------------------------	----------------------------

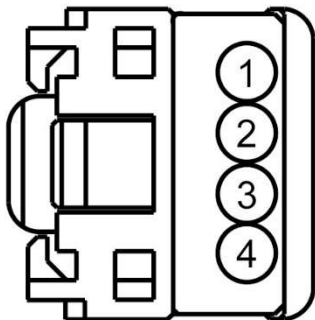

[Check for Terminal Part Numbers](#)

Pin	Circuit	Gauge	Circuit Function	Qualifier
1	CPL42 (BY-VE)	22	SWITCH - TRIM DOOR LOCK (DRIVER) # LOCK	
2	RPN60 (BU-ON)	22	CTRL MOD - POWER WINDOW SWITCH DRIVER RETURN	
3	CPL43 (VT-07)	22	SWITCH - TRIM DOOR LOCK (DRIVER) # UNLOCK	
4	CPL77 (BU-ON)	22	CTRL MOD - DOOR LOCK # SWITCH TRIM DOOR LOCK DRIVER ILLUMINATION	

Connector:	Description	Color	Harness	Base Part #	Service Pigtail
C541	FRONT DOOR LOCK SWITCH LH	BK	14631	part# N/A	See Below

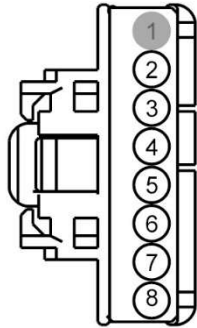

Pin	Circuit	Gauge	Circuit Function	Qualifier
1	-	-	Not Used	
2	CPL77 (BU-GN)	22	CTRL MOD.; DOOR LOCK # SWITCH TRIM DOOR LOCK DRIVER ILLUMINATION	
3	CPS17 (BU-DO)	22	SWITCH - MEMORY DRIVER P3	
4	CPS18 (YE)	22	SWITCH - MEMORY DRIVER P2	
5	CPS15 (VT-WH)	22	SWITCH - MEMORY DRIVER P1	
6	RPW03 (BU-GN)	22	CTRL MOD.; POWER WINDOW SWITCH DRIVER RETURN	
7	CPL42 (GY-YE)	22	SWITCH - TRIM DOOR LOCK (DRIVER) # LOCK	
8	CPL43 (VT-GY)	22	SWITCH - TRIM DOOR LOCK (DRIVER) # UNLOCK	

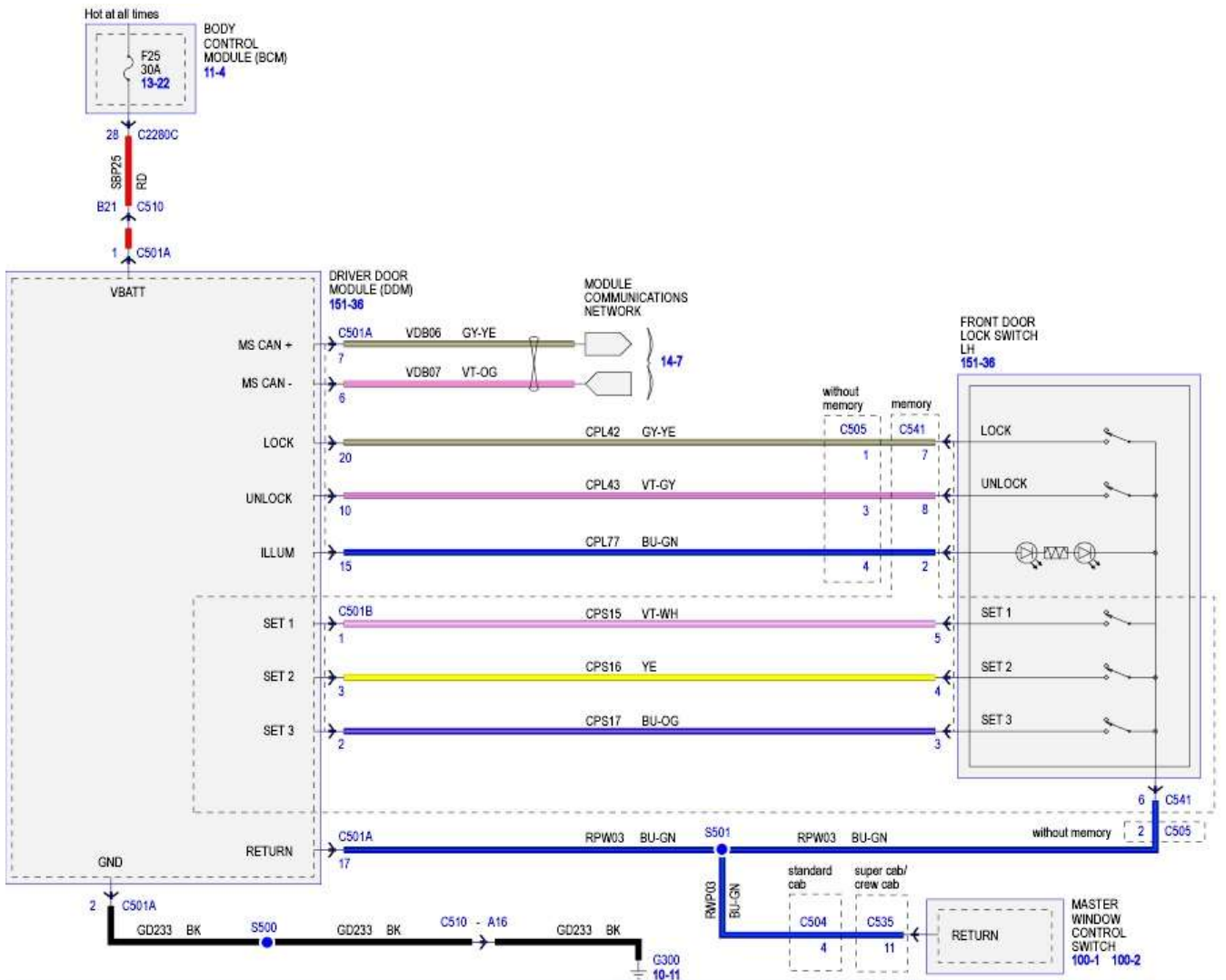

### Spot Lamp Wiring Modification – Allows Spot Lamps to Function Above 5 MPH\*\*

- Cut / terminate CLF 76 GY wire (pin #2) approx. 1" behind Spot Lamp Module C2506B Connector. Tape and secure CLF 76 GY wire protruding from dash harness – this wire will no longer be used. Run short jumper wire from SBB16 VT-RD wire (pin #1) of C2506B connector to CLF 76 GY wire

protruding from C2506B connector. SBB16 VT-RD wire now provides constant 12V+ to Pin #2 of C2506B connector. Refer to attached wiring diagram.

**\*\*Note:** if choosing this method to enable the spot lamps, it is possible to exit the vehicle and inadvertently leave the spot lamps on as they are no longer controlled by the BCM.

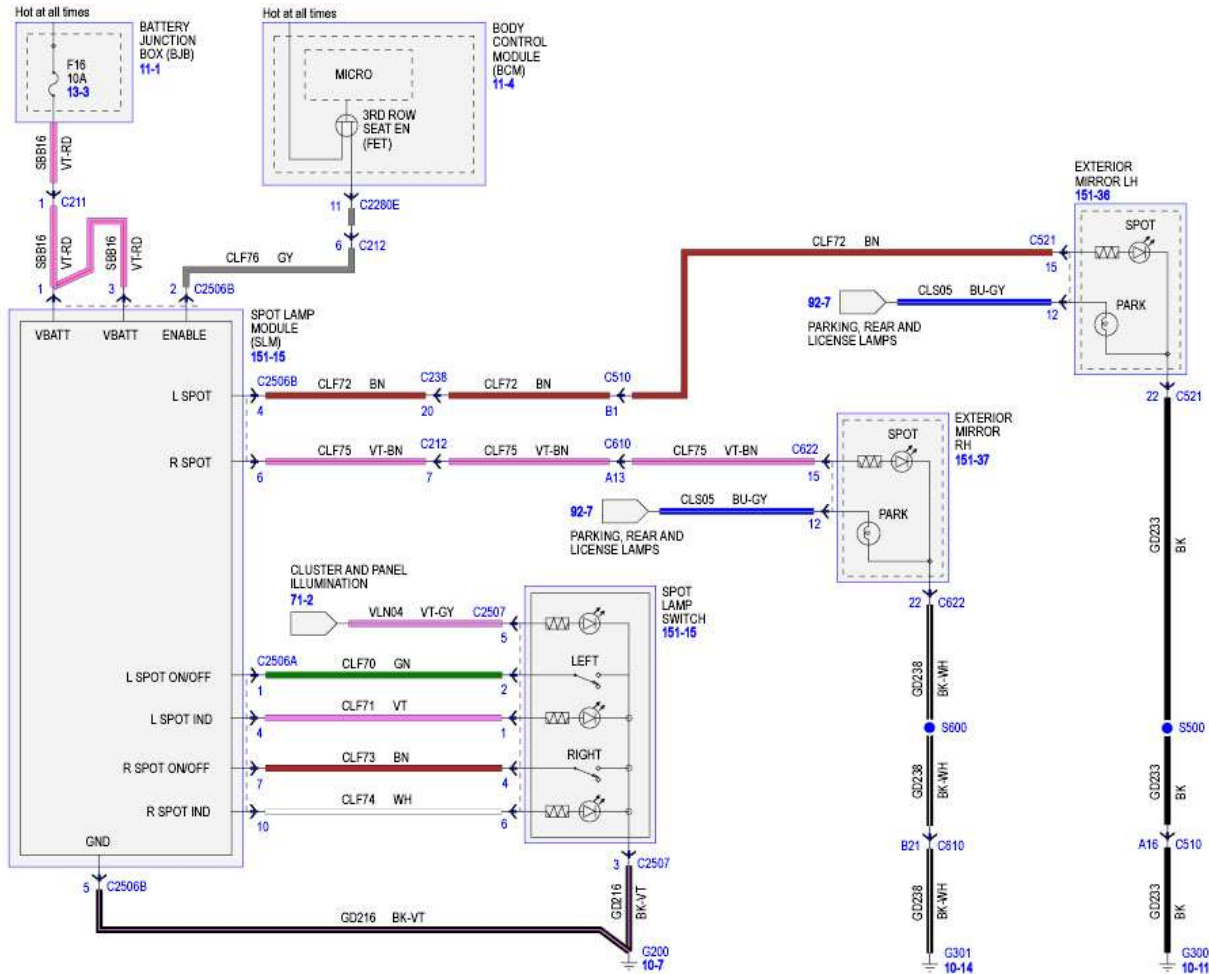

### Spot Lamp Enable – without spot lamp module wiring modification

- Using FORScan change BCM address 726-56-01 from XXXX X0XX XXXX to XXXX X1XX XXXX (Spotlight Cfg: **0**=disable, **1**=enable). In most applications the new 726-56-01 value will be 0000 0100 0186.

### Auto Fold Option

- On **Trailer Tow Mirrors only**, pins # 18 and 19 (mirror fold in/out) at exterior mirror harness connector (Driver side - C521 & Passenger side - C622) must be swapped – refer to attached photos
  - Remove interior sail trim panel from door
  - Unplug exterior mirror wiring harness connector and remove the red lock. The outside edge just needs to be flexed enough to slide away from the connector.
  - Remove pins # 18 & 19 and swap their positions\*\*:

- Driver side colors: Pin # 18 - Violet / Brown & Pin # 19 - Green / Violet
  - Passenger side colors: Pin # 18 Brown & Pin # 19 White / Orange
  - If you damage a wire terminal, the replacement pigtail part # is DU2Z-14474-CA (WT-1002)
- **\*\***On the back of the exterior mirror harness connector you will see small numbers in the corners indicating pin location - 1, 11, 12, 22

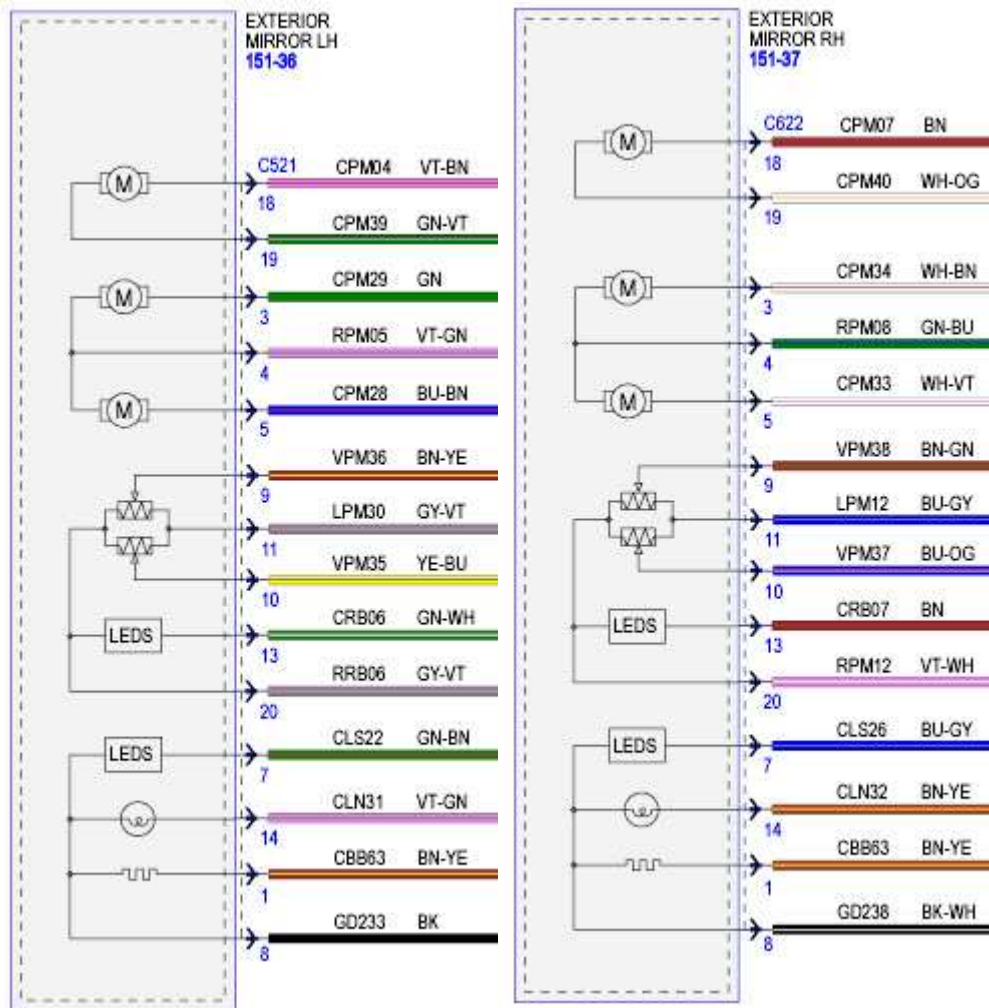

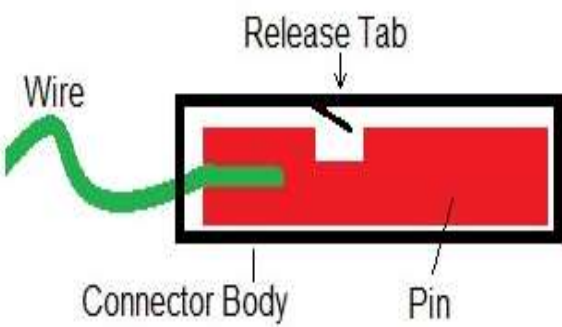
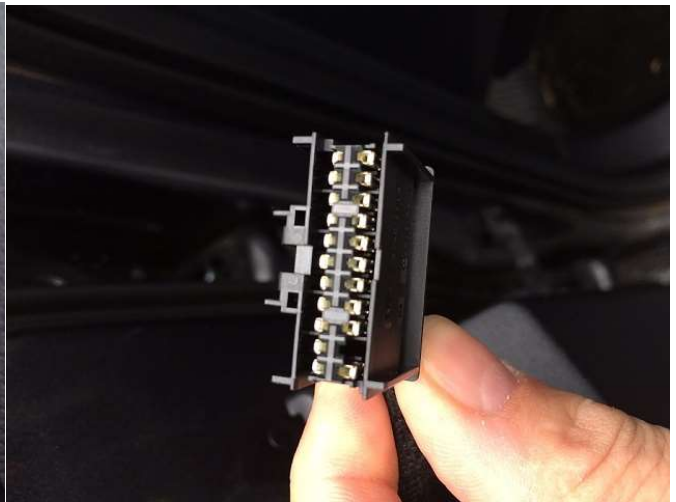

- Reprogram Driver & Passenger Door Modules (both Trailer Tow & Non-Trailer Tow Mirrors). Note:  
There are 2 programming options for Auto Fold: Auto Fold with Key Fob & Auto Fold Lincoln Style.

**Auto Fold with Key Fob:**

Mirror Feature	Driver's Door Module			Passenger's Door Module		
Auto Fold with Key Fob	740-03-01	A800	F3	741-03-01	A800	F4
	740-12-01	F04A		741-12-01	F04B	

**Auto Fold Lincoln Style:**

Mirror Feature	Driver's Door Module			Passenger's Door Module		
Auto Fold - Lincoln Style	740-03-01	A840	33	741-03-01	A840	34
	740-12-01	F04A		741-12-01	F04B	

**Note:** Mirrors will fold closed via lock button on fob but will only unfold when driver's door is opened/closed.

This is helpful if you find yourself often unlocking truck to grab something from inside but don't want the mirrors unfolding (provided you use any door but driver's for entry)