

Transmission Fluid Level Check**Inspection**

NOTICE: The vehicle should not be driven if the transmission fluid level is low. Internal failure could result.

NOTE: If the vehicle has been operated for an extended period at high highway speeds, in city traffic, during hot weather or while pulling a trailer, the transmission fluid must cool down to obtain an accurate reading.

NOTE: Do not overfill the transmission. The transmission fluid level must be at the upper level of the dotted (B) area marks on the transmission fluid level indicator.

NOTE: If a new transmission fluid cooler or new fluid cooler tubes have been installed, drive the vehicle to warm the transmission fluid to 96.7°C-102°C (206°F-215°F) in order to purge the air from the transmission fluid cooling system.

1. Connect the diagnostic scan tool and position the vehicle on a hoist.
Refer to: [Jacking and Lifting - Overview](#) (100-02 Jacking and Lifting, Description and Operation).
2. With the engine running, place the transmission selector lever in each gear position, holding approximately 5 seconds in each position. Place the transmission selector lever in PARK.

Refer to: [Engine Rear Undershield](#) (501-02 Front End Body Panels, Removal and Installation).

3. Remove the transmission fluid fill plug and remove the transmission fluid level indicator from the plug.

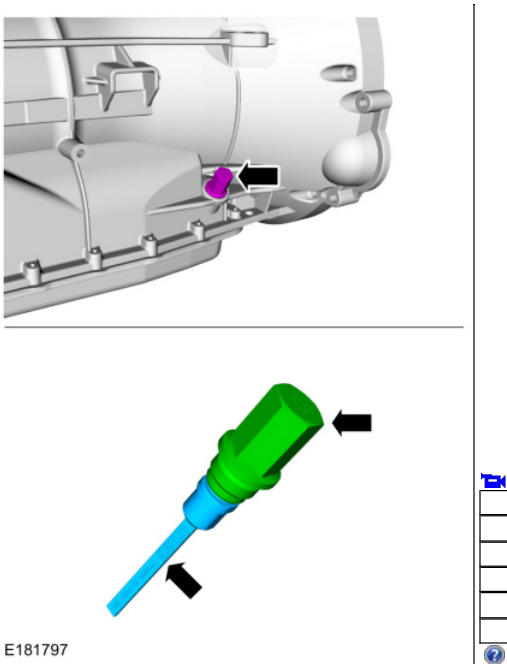

4. Check the transmission fluid level using the transmission fluid level indicator.



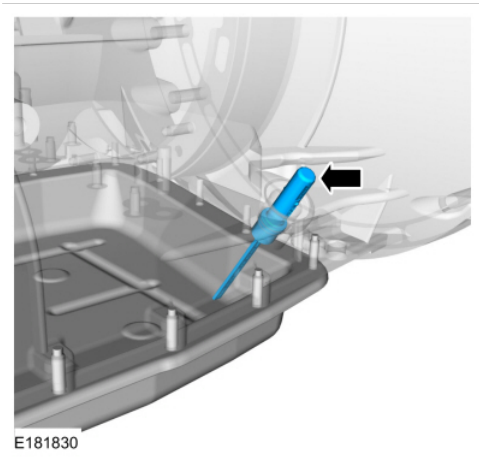

5. **NOTE:** The transmission fluid level indicator has 2 areas for the fluid level, a crosshatched (A) area and a dotted (B) area. Use the dotted (B) area when checking the transmission fluid level. The correct transmission fluid level is at the upper level of the dotted (B) area marks on the transmission fluid level indicator.

Using the scan tool verify the transmission fluid temperature is between 96.7°C - 102°C (206°F - 215°F). The transmission fluid level must be at the upper level of the dotted (B) area.

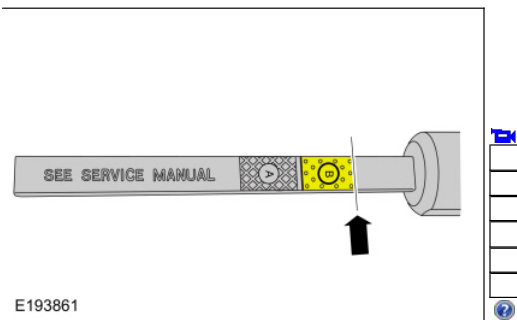

6. If the transmission fluid is not at the correct level, follow the steps for adding or removing transmission fluid. Refer to: [Transmission Fluid Drain and Refill](#) (307-01 Automatic Transmission, General Procedures).
7. Install the transmission fluid fill plug.
Torque: 26 lb.ft (35 Nm)

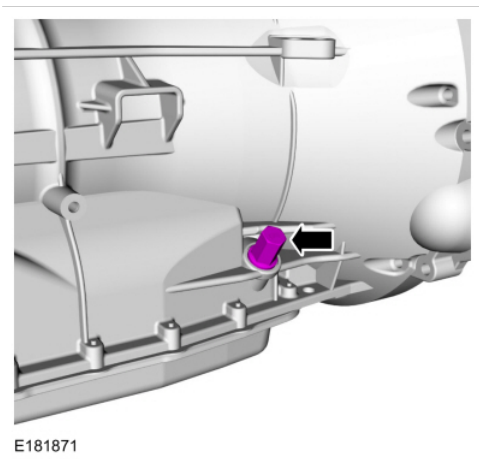

Refer to: [Engine Rear Undershield](#) (501-02 Front End Body Panels, Removal and Installation).

Copyright © 2017 Ford Motor Company

