



Transmission Fluid Drain and Refill

Special Tool(s) / General Equipment

	307-570 Tube, Transmission Fill TKIT-2006U-F/FM TKIT-2006U-FLM/LM TKIT-2006U-ROW1 TKIT-2006U-ROW2
	307-D465 Transporter Fluid Evacuator/Injector
 416-D002	416-D002 Vacuum Pump Kit

Materials

Name	Specification
Motorcraft® MERCON® ULV Automatic Transmission Fluid XT-12-ULV	WSS-M2C94-A

Draining

- NOTE:** The transmission fluid pan must be removed to drain the transmission fluid. Follow the steps in the Transmission Fluid Pan, Gasket and Filter procedure to remove and install the transmission fluid pan. It is not necessary to remove the transmission fluid filter to drain the transmission fluid.

Remove the transmission fluid pan to drain the transmission fluid.

Refer to: [Transmission Fluid Pan, Gasket and Filter](#) (307-01B Automatic Transmission - 10-Speed Automatic Transmission - 10R80, Removal and Installation).

Filling

NOTICE: This procedure contains the air purge steps required to purge air from the transmission fluid cooling system. This procedure is NOT intended for use with the Transmission Fluid Level Check.

NOTICE: The vehicle should not be driven if the transmission fluid level is low or internal failure could result.

NOTICE: The use of any other transmission fluid than specified can result in the transmission failing to operate in a normal manner or transmission failure.

NOTE: Check the transmission fluid level if the transmission starts to slip, shifts slowly or shows signs of transmission fluid leaking.

NOTE: Here is an overview of the Transmission Fluid Refill procedure.

- Adding 3.3L (3.5 qt) of transmission fluid is an initial fill enabling the engine to be started.
- Filling the transmission to the transmission fluid level indicator area below the crosshatch mark allows the vehicle to be driven.
- The vehicle should be driven to allow the transmission fluid temperature to reach 96°C - 101°C (206°F - 215°F) in order to purge the air from the transmission fluid cooling system.
- Fill the transmission fluid to the fill range on the transmission fluid level indicator at the normal operating range 96°C - 101°C (206°F - 215°F).

1. Remove the transmission fluid fill plug and remove the transmission fluid level indicator from the plug.

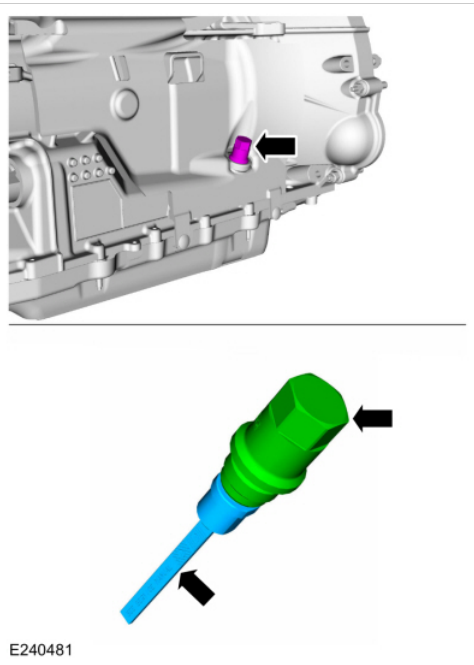

2. **NOTE:** The transmission will need 3.3L (3.5 qt) of transmission fluid added to the transmission as an initial fill if:
- a new main control has been installed.
 - the transmission fluid pan or transmission fluid filter have been removed.

NOTE: The transmission will need 11.35L (12 qt) of transmission fluid added to the transmission as an initial fill if the transmission has been overhauled.

Using the special tools, add transmission fluid to the transmission through the transmission fluid fill hole.

Use Special Service Tool: [307-570 Tube, Transmission Fill](#), [307-D465 Transporter Fluid Evacuator/Injector](#).

Material: Motorcraft® MERCON® ULV Automatic Transmission Fluid / XT-12-ULV (WSS-M2C94-A)

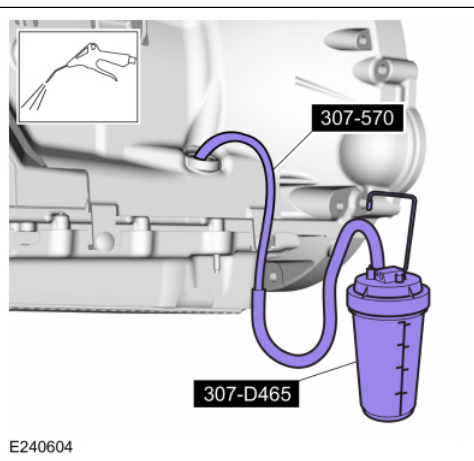

- 3.
1. Connect the diagnostic scan tool and monitor the transmission fluid temperature.
 2. Start the engine.
 3. Place the selector lever in each gear position, holding approximately 5 seconds in each position. Place the selector lever in PARK, with the engine at idle (600-750 rpm).
 - Check the transmission fluid level using the transmission fluid level indicator.



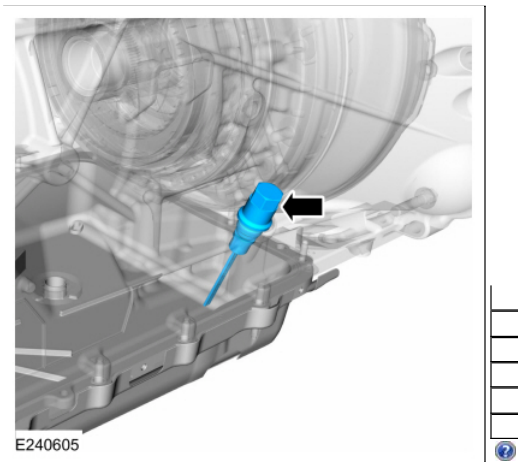

4. **NOTICE:** The vehicle is safe to drive with a cold transmission fluid temperature if the transmission fluid level is in the transmission fluid level indicator area below area "C" as shown. Failure to add transmission fluid to this level can result in damage to the transmission.

Add transmission fluid to the area on the transmission fluid level indicator below the area "C".

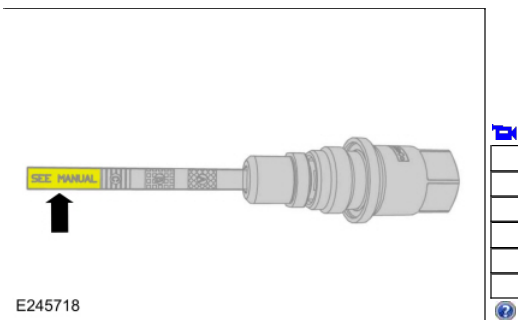

5. Install the transmission fluid fill plug.
Torque: 52 lb.ft (70 Nm)

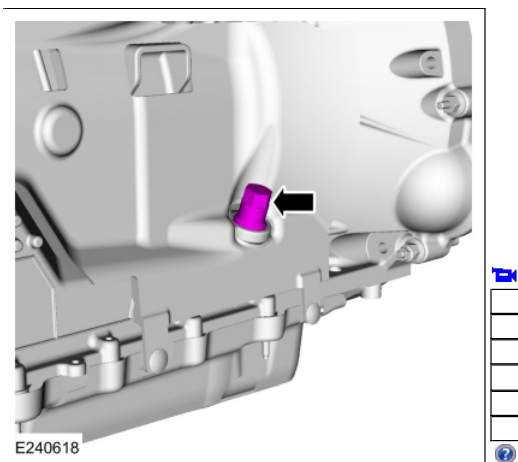

6. **NOTE:** Always drive the vehicle in a safe manner according to driving conditions and obey all traffic laws.

Drive the vehicle. While driving the vehicle, use the scan tool to verify the transmission fluid has reached a temperature of 96°C - 101°C (206°F - 215°F). This circulates the transmission fluid through the torque converter and the transmission fluid cooling system, eliminating any trapped air in the transmission fluid cooling system. With the engine idling (600-750 rpm) in PARK, verify the transmission fluid temperature is between 96°C - 101°C (206°F - 215°F) and lift the vehicle on a hoist. Refer to: [Jacking and Lifting - Overview](#) (100-02 Jacking and Lifting, Description and Operation).

7. Remove the transmission fluid fill plug and remove the transmission fluid level indicator from the plug.

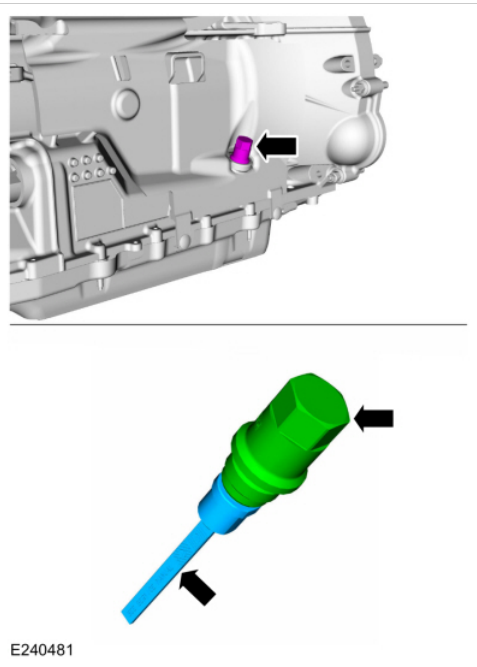

8. Check the transmission fluid level using the transmission fluid level indicator.

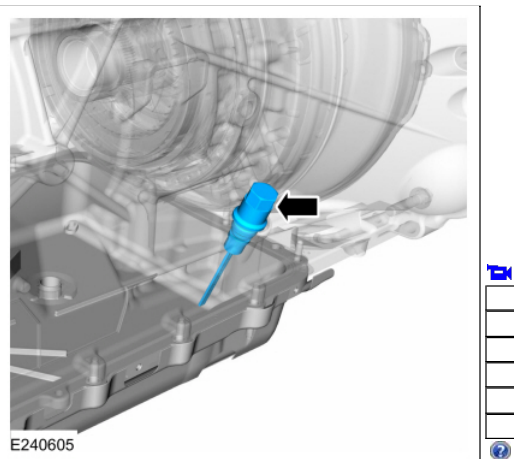

9. **NOTE:** The transmission fluid level indicator has 3 areas for the fluid level, A, B and C as shown. Use the area "B" when checking the transmission fluid level. The correct transmission fluid level is at the center of the middle checkered zone labelled "B" on the transmission fluid level indicator.

Using the scan tool verify the transmission fluid temperature is between 96°C - 101°C (206°F - 215°F). The transmission fluid level must be at the center of the middle checkered zone labelled "B" on the transmission fluid level indicator.

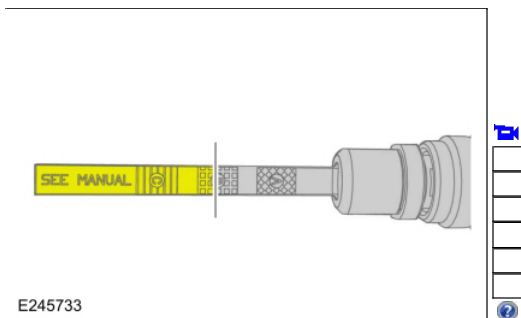

10. If the transmission fluid level is low, add transmission fluid using the special tools.
 Use Special Service Tool: [307-570 Tube, Transmission Fill](#), [307-D465 Transporter Fluid Evacuator/Injector](#).
 Material: Motorcraft® MERCON® ULV Automatic Transmission Fluid / XT-12-ULV (WSS-M2C94-A)

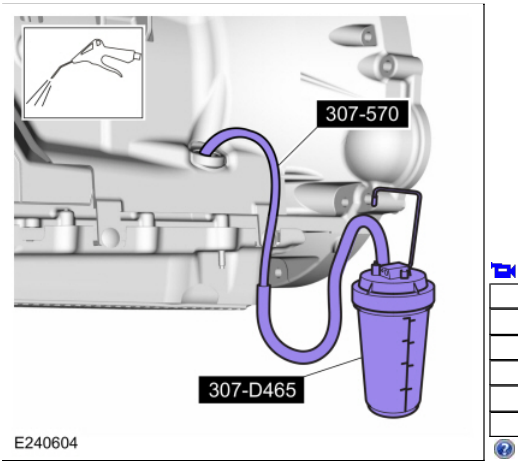

- 11. If the transmission fluid is overfilled, remove transmission fluid using the special tools.
Use Special Service Tool: [307-570 Tube, Transmission Fill.](#) , [307-D465 Transporter Fluid Evacuator/Injector.](#) , [416-D002 Vacuum Pump Kit.](#)
Material: Motorcraft® MERCON® ULV Automatic Transmission Fluid / XT-12-ULV (WSS-M2C94-A)

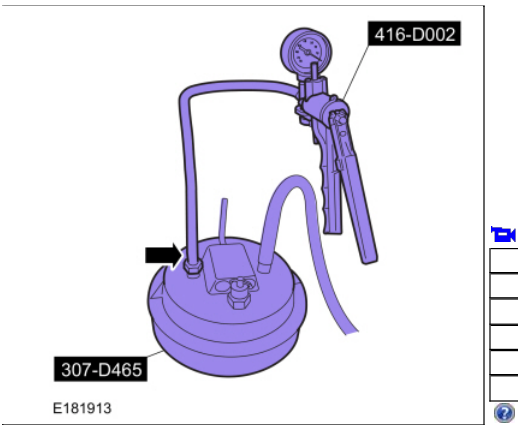

- 12. Install the transmission fluid fill plug.
Torque: 52 lb.ft (70 Nm)

