



Light Wiring Tutorial

JcrOffroad does not make any claims that these diagrams will work safely or properly. We are not electrical engineers. Any evidence to the contrary is clearly coincidental. Use these diagrams as a guide and at your own risk. We are not responsible for any damage to your body, vehicle, family or pets.



A word on the SPST Bosch Style Relay

Relays can be confusing for people, but they can do some very fun things.

Think of the relay as merely a switch. Terminal 30 will connect to terminal 87 when the switch is on, and to terminal 87a when the switch is off. Instead of you having to manually turn the switch on and off with a toggle, there is an electromagnetic toggle built into the relay.

Connect 12v of power to terminal 86 and a ground to terminal 85 and the relay is on. Take either the power or ground away and it's off. Easy.

So why use them? A single relay will allow you to keep the main power to your accessory as short as possible. For instance instead of running power from your battery into the cab of your vehicle to a switch, then from the switch back outside of the vehicle to your accessory (20+ feet of wire) you can run the main power from the battery straight to the accessory with a relay in that circuit. This means less power drop for your accessory, cheaper wire costs, and it's safer to keep the large amperage draws out of the cab too.

The other benefit of the relay is the low power draw on the switching side (~0.160 amps.) This means you can switch the relay (86 and 85 terminals) off nearly any circuit without fear of damage.

Want your aftermarket driving lights to come on only when the parking lamps are on, no matter what position your toggle switch is in? Tap into the parking lamps 12v + wire from somewhere in the dash (or an non dimming illumination wire in your dash) to use as the positive side of your toggle switch. Then run the acc side of your toggle to the 86 terminal on the relay. Whenever your parking lamps are on, and the toggle is on, you're driving lamps will be on too.

You can use the above theory with any circuit you like. Cigarette lighter, accessory outlet, headlamps, radio turn on lead... whatever. You can even switch the negative side of a relay with door grounding pins, etc... You can even power the switch side of one relay with the load side of another for more complex circuits.

The Diagrams

Basic Relay Use

This is a basic accessory wiring diagram (you can replace the lamps in this drawing with whatever 12v accessory you'd like)

The components can go where ever you like, or where ever gives you the easiest wire runs, as long as the diagram is followed. For instance, the fuses and relay in this diagram can go next to the battery with the switch in the cab, and lights on the front or back bumper. Or the fuses can go next to the battery, switch in the cab, with the relay and lights behind the back bumper.

As stated above, the switch does not have to be powered from the battery, you can use key acc, cigarette lighter +, whatever you like.

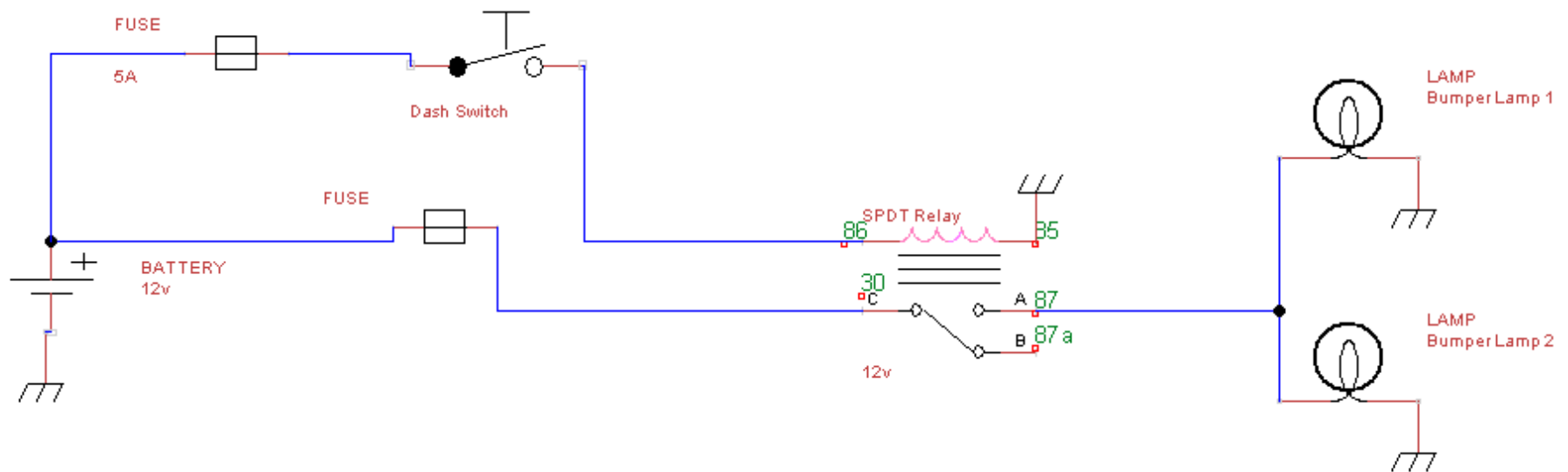

Aftermarket lamps on with factory backup lights

This circuit will turn the aftermarket lamps on whenever the factory backup lamps are on. There is no override to keep the aftermarket lights off at all times.

You may be able to tap into the factory backup lamp 12v+ wire near the PDC under the hood (if available) and leave the relay by the battery for the shortest wire run.

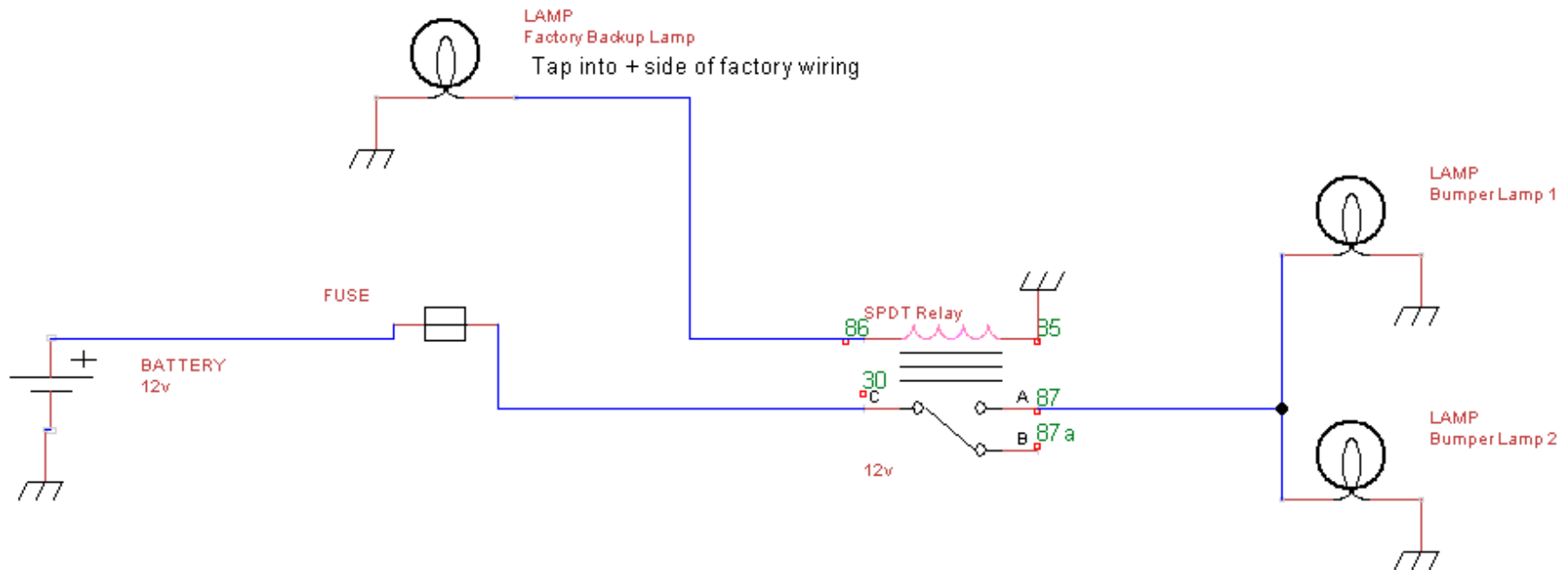

Aftermarket lamps on with factory backup lights OR switched

This circuit will turn the aftermarket lamps on whenever the factory backup lamps are on OR whenever the switch in the cab is on. There is no override to keep the aftermarket lights off at all times.

Finding a place to tap into the factory backup lights in the cab or in the PDC and keeping the relay under the hood in this instance can help make these wire runs shorter.

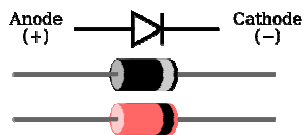

The diodes

These are used to keep power from the switch or factory backup lamps from back feeding each other. They are capable of 3a sustained. Part #1N5402 is a standard diode part available at your local Radio Shack or online.

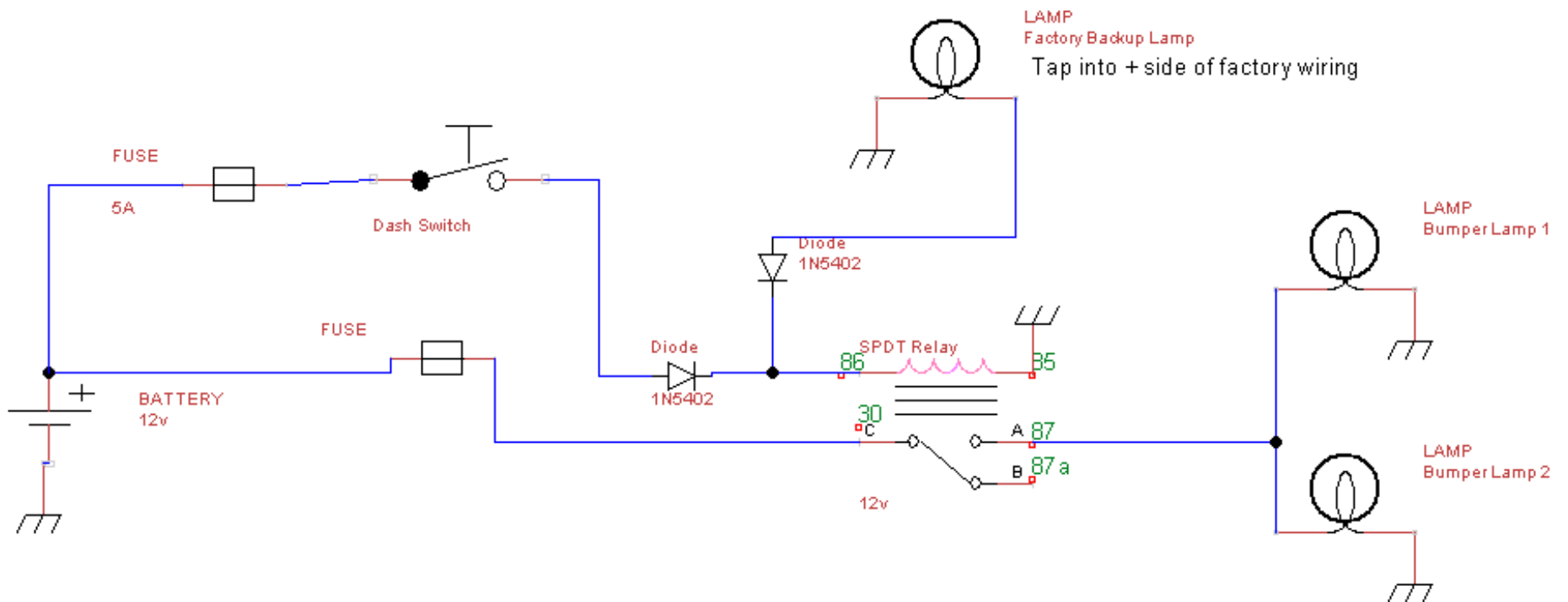

Aftermarket lamps on with factory backup lights OR switched OR always off.

This circuit will turn the aftermarket lamps on whenever the factory backup lamps are on OR whenever the switch in the cab is on. There is also an override for keeping the accessory lamps off at all times.

This circuit uses an on - off - on toggle. One side is being powered by the factory backup lights, one side by whatever 12v+ you chose, and the center position on the switch will have no contact. When left in the center position, the accessory lights will stay off no matter what.

When left in the up position the accessory lamps will be on only with the factory backup lights.

The lamps can be turned on at any time (depending on which + wire you tap into) by the switch in the down position.

Finding a place to tap into the factory backup lights in the cab or in the PDC can help make these wire runs shorter. Also keeping the relay under the hood in this instance can help too.

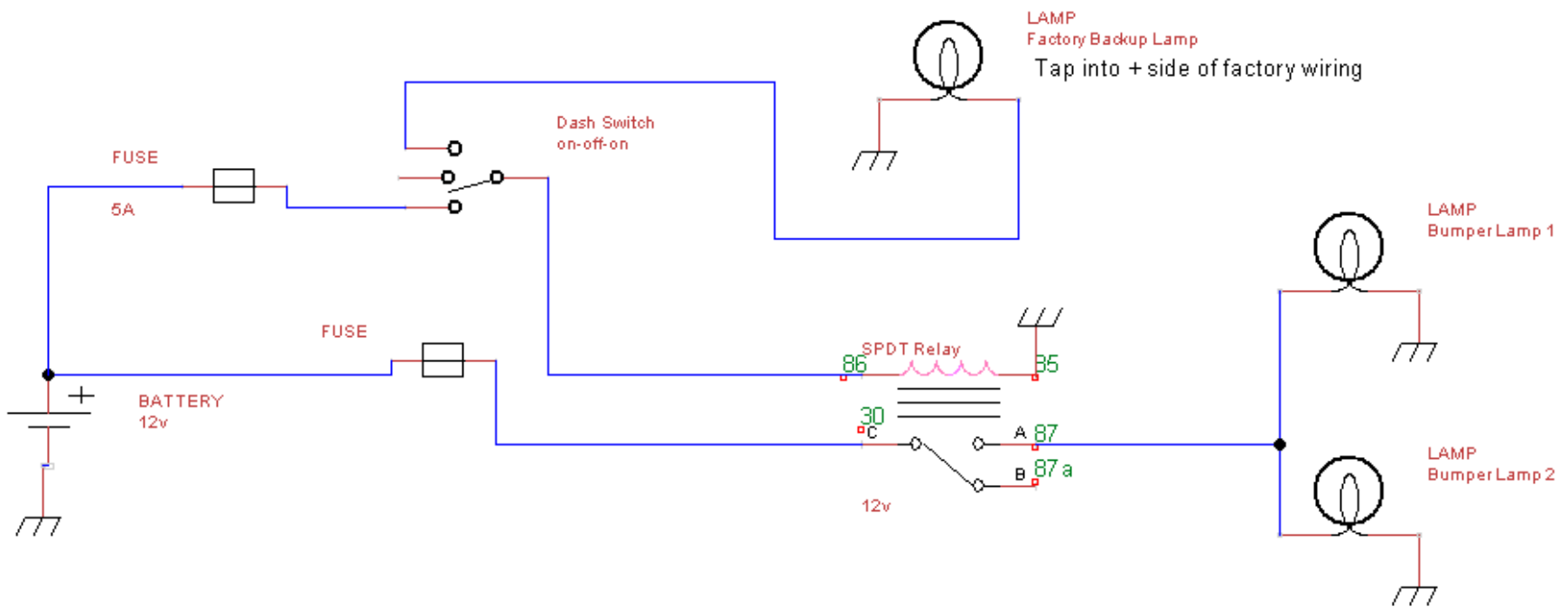

Toggle switch wiring for above

Without internally rewiring the switch there is no easy way to use an illuminated switch in this instance. This is because we are technically using the switch backwards and the illumination will be on all the time.

